

Design and Function of Weight-Loaded Pressure / Vacuum Vents

OBJECTIVE

Protectoseal Weight Loaded Breather Vents are designed for use on liquid storage tanks, process tanks and processing systems that operate at nominal pressures of 15 PSIG or less. Their function is to prevent damage to the tank should pressure or vacuum conditions in excess of the tank's design parameters be encountered.

This article provides a basic overview of the design and function of weight loaded vents and also explains how a vent provides protection for the tank structure.

DEFINITIONS & VENT COMPONENT DESCRIPTIONS

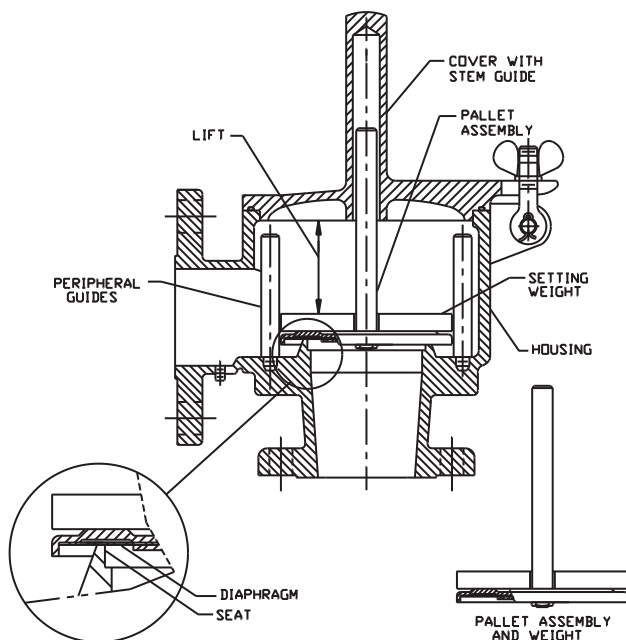

Tank Vent - A device designed to provide pressure and / or vacuum relief for atmospheric or low pressure storage tanks. A vent may be end-of-line (venting to atmosphere) or pipe-away (venting through an outlet flange connection to a secondary storage or processing location).

Set Point - The tank pressure / vacuum at which the force resulting from tank pressure acting on the pallet assembly equals the sealing force of the pallet assembly and setting weights - - the pressure at which the vents begins to open.

Pallet Assembly - The weight-loaded assembly housed within the vent that moves in response to the tank pressure, allowing flow into or out of the tank. The pallet assembly covers and seals the vent seat when in the closed position.

Seat - The precisely machined orifice within the vent housing on which the pallet assembly sits when closed. The inside diameter of this seat is the flow path for vapors / air entering or leaving the tank's vapor space.



Series 8540H
End-of-Line Conservation
Breather Vent

Diaphragm - The sealing (gasket) material that is part of the pallet assembly and which seals against the seat surface when the vent is closed.

Lift - Minimum distance (determined by manufacturer) that the pallet assembly must lift off the seat before being mechanically stopped. This lift must be measured when all setting weights are properly installed in the vent. The minimum lift must be maintained if the full flow capacity of the vent is to be available.



Cutaway of Air-Cushioned Pallet Assembly



Pallet Assembly in Relieving Position

Housing - Flanged to mate with a connection on the storage tank or process piping.

Setting Weights - Metal plates that mount on the pallet assembly and provide the total weight required for a particular vent set point.

Stem Guide & Peripheral Guides - Ensure that the pallet assembly remains in proper alignment with the seat during the relieving cycle of the vent.

Minimum Set Point - The lowest set point that can be provided with a specific size and style of vent.

Maximum Set Point - The highest set point that can be provided with a specific size and style of vent.

PRESSURE / VACUUM HAZARDS

The use of large capacity tanks and vessels for the temporary storage of flammable or combustible liquids is common. These tanks are fixed volume containers that temporarily hold liquids that are transferred (filling and emptying) through the tank piping systems. The volume above the liquid level in a tank is called the vapor space.

Assume that a tank is completely vapor tight. Filling the tank raises the liquid level and causes the vapor space to decrease (vapors are compressed), with a resulting increase in the pressure in the vapor space. Alternatively, if liquid is withdrawn from the tank, the vapor space increases (vapors are allowed to expand) and the pressure in the vapor space decreases.

Now assume that the tank is again completely vapor tight. No liquid is being transferred (the liquid level does not change), but the liquid in the tank is being heated or cooled. The additional of heat causes vapors to

be generated from the stored liquid and evolve into the closed vapor space. The result is an increase in pressure in the vapor space. Cooling of the liquid leads to contraction of the vapors and a corresponding pressure decrease in the vapor space.

In addition to protecting the tank from excessive pressure and vacuum, properly applied vents also conserve product and minimize tank emissions. The vents open only when necessary to relieve pressure / vacuum. At all other times, the vents are closed and no open holes connect the tank's vapor space to the atmosphere.

The scenarios outlined above reflect the common hazards associated with the storage of flammable liquids in fixed roof tanks. Unless the tanks are equipped with properly designed and specified venting devices, excessive pressure and/or vacuum accumulations in the vapor space can result in severe tank damage.

VENT FUNCTION

Protectoseal Pressure / Vacuum Vents are connected to a nozzle that leads to the tank's vapor space. Each vent includes a machined seat that is closed by a moveable pallet assembly. The pallet assembly is designed to provide a specific amount of closing force. The amount of closing force determines the set point of the vent.

Pressure Venting - The pressure in the tank's vapor space pushes against the pallet assembly over an area defined by the machined seat orifice, in opposition to the closing force (combined force of pallet assembly weight, setting weights and atmospheric pressure). When the tank pressure is such that the opening force and closing force are equal, the set point is reached and the pallet assembly lifts. Vapors are allowed to escape from the tank through the vent.

Vacuum Venting - Negative pressure (vacuum) is created in the tank's vapor space and in the housing of the vent. Atmospheric pressure pushes against the pallet assembly seat diameter, opposed by the closing force (combined force of pallet assembly weight, setting weights and negative gauge pressure in vent housing). When the force created by the atmospheric pressure equals the closing force, the vacuum set point is reached and the pallet assembly lifts, allowing air to enter the tank's vapor space through the vent housing.

In the manner, the vent insured that the tank's vapor space is maintained within a safe operating range.

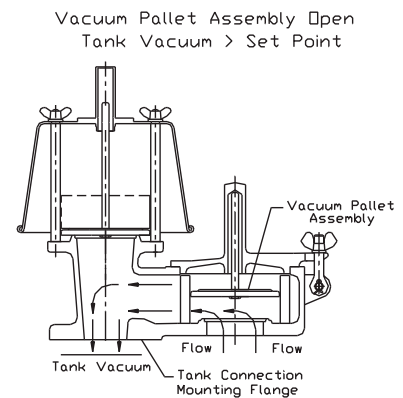
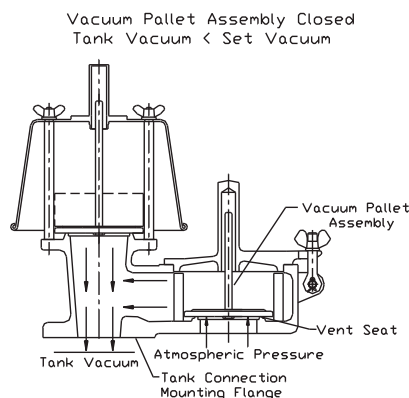
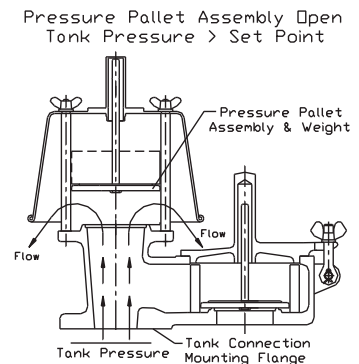
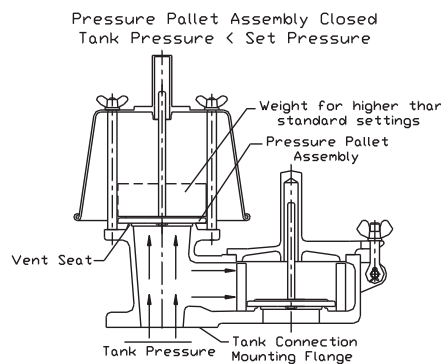

Protectoseal Storage Tank Fittings, Vents and Accessories are sold and serviced by a technically-oriented network of representatives located across the United States, Mexico, Canada, South America, Europe, Middle / Far East and elsewhere throughout the industrial world.

Please call 1-630/595-0800 or visit our website at www.protectoseal.com for the name and address of the Protectoseal Representative in your area.



THE PROTECTOSEAL COMPANY

ISO 9001 CERTIFIED

225 Foster Ave., Bensenville, IL 60106-1690
Ph: 1-630-595-0800 Fax: 1-630-595-8059

SAFETY WITHOUT COMPROMISE