

RA Series Declutchable Manual Override

Introduction

The Automax rotary manual override sandwich mounts between the actuator and the valve/damper. The self-locking declutchable worm gear design provides a secure, easily engaged, long lasting override for the Automax SuperNova SNA series.



The LV1 lockout and vent valve shuts off the air supply and vents the actuator allowing manual operation.

- Manual operation purges the air from one side of the pistons to the other, preventing corrosive atmosphere from being drawn into the actuator.
- Direct mounts to the NAMUR air porting of the SuperNova SNA series actuator, eliminating the need for tubing and fittings.
- Can be combined with other Automax NAMUR accessories such as the APS1 & 2, flow controls, & A25N solenoid valves.

Installation

1. Note the valve position (open or closed) and ensure that the RA operator and the actuator are in the corresponding position.

• To position RA operator, refer to Operation, Step #3.

2. The RA operator comes with the correct bracket and drive coupling for the actuator specified. Place the actuator on the RA, aligning the coupler and actuator pinion.
3. Insert actuator mounting studs, install RA operator, and tighten nuts with lockwashers until snug. Cycle actuator several times, then tighten fully.

4. Install the RA / valve AutoBrakit to the valve and mount the RA and actuator to the kit.
5. Tighten the nuts and bolts until snug, stroke the actuator several times to properly align coupler, then tighten fully.
6. After mounting the actuator to valve, the gear override travel stops must be set. The travel stops should be set so that the actuator travel is stopped by the gear override travel stops rather than the actuator travel stops. This allows the valve to be independently operated with the actuator removed.
7. Set the actuator travel stops to correspond to the gear travel stops.

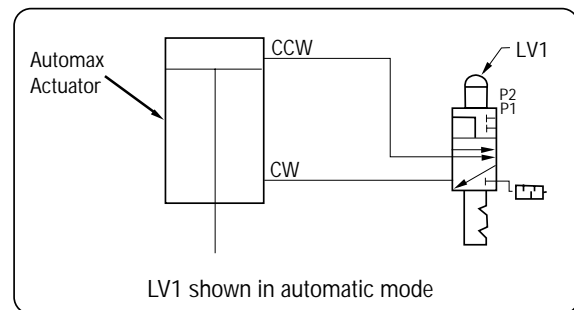

Operation

1. Actuator will operate normally with RA override declutched.
2. Manual operation requires that the supply air is shut off and the actuator vented. Pull the knob on LV1 vent valve to accomplish this.
3. Momentarily lift the lock pin and rotate the declutch bar clockwise 180° (toward the actuator) until the lock pin drops down. The worm gear is now engaged. Rotate handwheel until desired valve position is reached.

• To rotate the declutch bar fully, it may be necessary to turn the handwheel slightly mesh to the gears.

4. To return to automatic operation, rotate handwheel to desired valve position (or full failed position for spring return actuators). Momentarily lift the lock pin and rotate the declutch bar counter-clockwise 180° until the lock pin engages.
5. Push in the knob on the LV1 to reconnect the air supply lines.