

Flowserve Corporation
Flow Control Division
www.flowserve.com

1350 N. Mountain Springs Parkway
Springville, Utah 84663-3004
Phone: 801 489 8611

1978 Foreman Dr.
Cookeville, TN 38501
Phone: 931 432 4021

SNA250 / SNA300

All actuators are factory lubricated for life, but still should be protected from the elements and stored indoors until ready for use. The ports of the actuator are plugged as supplied from the factory. If actuators are stored for a long period of time prior to installation, the units should be stroked periodically to prevent the seals from taking a set.

Prior to assembly, check the mounting surfaces, the stem adaptor and the bracket to assure proper fit. Manually open and close the valve to insure freeness of operation. Be sure the valve and Automax actuator rotate in the same direction and are in the same position (i.e., valve open, actuator open). Secure the valve with the stem vertical. Bolt the bracket to the valve and place the stem adaptor on the valve stem. Position the actuator over the valve and lower to engage the stem adaptor to the actuator shaft.

Continue to lower until the actuator seats on the bracket mounting surface. In order to align the bolt holes, it may be

necessary to turn or stroke the actuator a few degrees and/or adjust the actuators travel stops. Bolt the actuator to the bracket.

After consulting the valve manufacturer's recommendations, adjust the travel stop bolts of the actuator for the proper open or closed valve position. Adjust the Stop Bolt (8) until the desired travel is obtained and reinstall O-ring (10) and Nut (9). Pneumatically stroke the actuator several times to ensure proper operation with no binding of the stem adaptor. If the actuator is equipped with an UltraSwitch or other accessories, adjust them at this time.

To prolong actuator life use only clean, dry plant air. Lubricated air is not required, however it is recommended particularly for high cycle applications. **CAUTION: Do not use lubricated air with positioners.**

Dimensional Information

MODEL	SNA250	SNA300
A (DA & SR)	27.32	32.60
180°	39.14	44.00
B	4.250	5.000
C	5/8 - 11x.63	5/8 - 11x.86
D	2.87	N/A
E	1.850	N/A
F	1.81	2.50
G	11.02	13.39
H(NPT)	1/2	1/2
J	5.91	6.30
K	11.02	13.39
L	1.181	1.181
M	5.118	5.118
N②③	10 - 24	10 - 24
OØ	2.20	2.44
P	1.969	1.969
PP	0.98	0.98
QØ	3.75	3.75
R	1.65	1.65
S	0.24	N/A
Wts. lbs. (DA)	137	217
Wts. lbs. (SR)	172	288
Volume (IN³) CW	757	1403
Volume (IN³) CCW	720	1019

Notes:

- Actuators shown in the full clockwise (CW) position as viewed from the accessory side.
- Accessory mounting holes not for gear override or stop block. Consult factory.
- Use studs only to mount. Bolts are not recommended.
- Air consumption per 90° =
$$\frac{V}{1728} \left(\frac{\text{Supply Pressure} + 14.7}{14.7} \right)$$
 (Standard cubic feet)

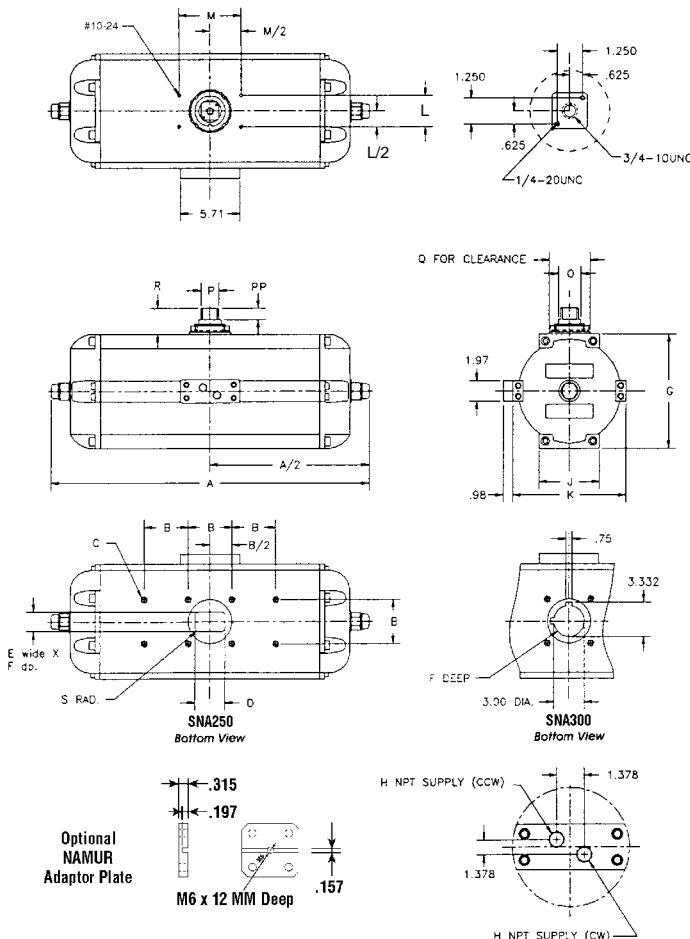

Operation (as viewed from top of actuator)

Double Acting

Applying air pressure to Port 1 drives the pistons outward, which turns the pinion counterclockwise as the air volume on the outside of the pistons exhausts through Port 2.

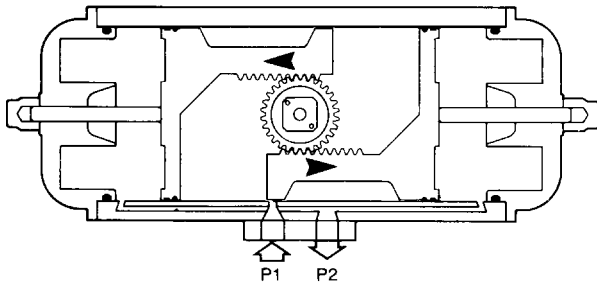

Applying air pressure to Port 2 drives the pistons inward, which turns the pinion clockwise as the air volume on the inside of the pistons exhausts through Port 1.

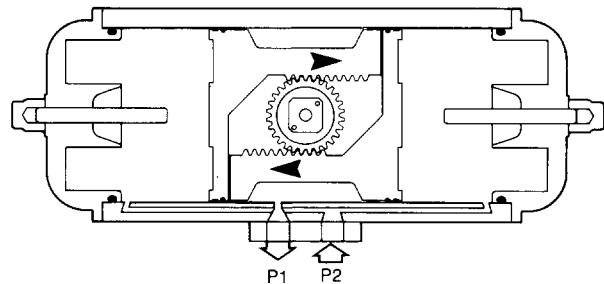

Spring Return (Fail CW)

Applying air pressure to Port 1 drives the pistons outward, which compresses the springs and turns the pinion counterclockwise as the air volume on the outside of the pistons exhausts through Port 2.

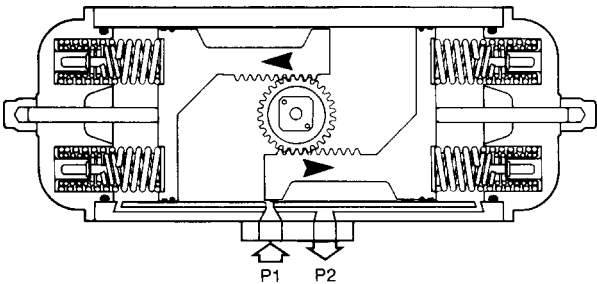

Exhausting the air pressure from Port 1 allows stored energy of the springs to drive pistons inward, turning the pinion clockwise. Air volume on outside of pistons vents through Port 2.

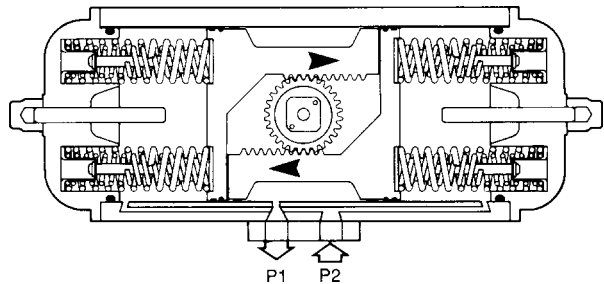

Spring Return (Fail CCW)

Applying air pressure to Port 1 drives the pistons outward, which compresses the springs and turns the pinion clockwise as the air volume on the outside of the pistons exhausts through Port 2.

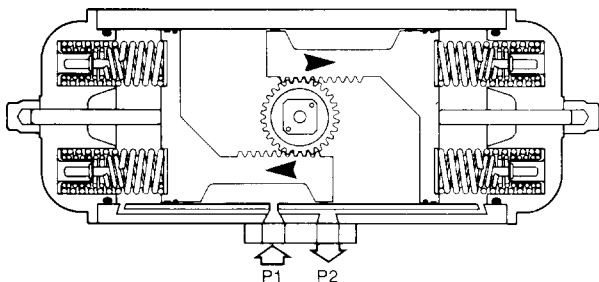

Exhausting the air pressure from Port 1 allows stored energy of the springs to drive pistons inward, turning the pinion counterclockwise. Air volume on outside of pistons vents through Port 2.

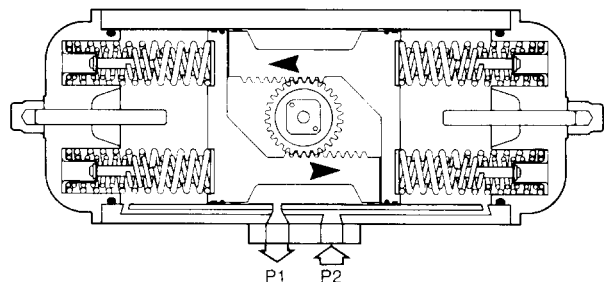

Maintenance Instructions

Disassembly Procedures

1. Disconnect all air and electrical supplies from actuator.
2. Remove all accessories from actuator and dismount actuator from valve.
3. Remove the 16 Endcap Screws (11, 12). When removing endcap screws on the supply side, apply low heat to loosen. Failure to apply heat may result in broken bolts.

WARNING: Loaded Springs in Endcaps, should be removed with caution.

4. SR - The Springs (21-24) will push the Endcaps off, releasing the spring load prior to the disengagement of the Endcap Screws (11, 12). Remove the Endcaps (2) and Spring Cartridge (21-24).
DA- Remove the Endcaps (2). Step 6 will push the Endcaps (2) from the Body (1).
5. Rotate Pinion (3) counterclockwise (DA & SR-FCW) or clockwise (DR & SR-FCCW) to drive the Pistons (16) off the end of the rack. Pull the Left Piston (16) from the Body (1).
6. Remove the Right Piston (16) by pushing out through inside of Body (1).
7. Remove the Pinion Snap Ring (7), and pinion washer (6).
8. Tap Pinion (3) lightly with plastic mallet to remove.

Changing Pinion Orientation

1. Disconnect all air and electrical supplies from actuator.
2. Remove all accessories from actuator and dismount actuator from valve.
3. Remove the Pinion Snap Ring (7) and Pinion Washer (6).
4. Tap Pinion (3) lightly with plastic mallet to remove.
5. Reverse Steps 3 & 4 with new Pinion (3) orientation.

Reassembly Procedures

1. Inspect all parts for wear and replace any worn parts as needed. Replace all 'O'-rings.
2. Clean all components and lightly grease cylinder bore, pinion and seals per temperature rating notes. See page 4.
3. Reverse the disassembly procedures to reassemble.
4. The standard Pinion (3) orientation is with the drive pocket parallel with the Body (1) in the CW position.
5. When fitting the Pistons (16) ensure the teeth engage the Pinion (3) at the same time by measuring in from the edge of the Body (1) the same distance from each end. Note: the orientation of the pistons will determine the operation of the actuator. Refer to the diagrams under "Operation" for correct piston position.
6. When assembling a spring return actuator, stand actuator cylinder vertical when inserting spring cartridges. If this is not possible, make sure spring cartridges are fully seated in piston pockets when installing Endcap.
7. Adjust the Stop Bolt (8) until the desired travel is obtained and reinstall O-ring (10) and Nut (9).
8. Test the actuator for smooth operation and air leakage at service pressure before reinstalling.

Changing Number of Springs

1. Follow the Disassembly Procedures through step 5.
2. Determine spring combination, consult catalog torque charts, distributor or factory. Simply add or remove one or more of the spring cartridges.
3. Reassemble the actuator, paying special note to step 6 in reassembling procedures.

Flowserve Corporation
Flow Control Division
www.flowserve.com

1350 N. Mountain Springs Parkway
Springville, Utah 84663-3004
Phone: 801 489 8611

1978 Foreman Dr.
Cookeville, TN 38501
Phone: 931 432 4021

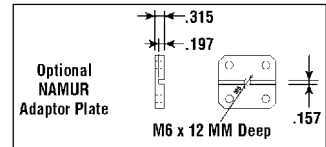
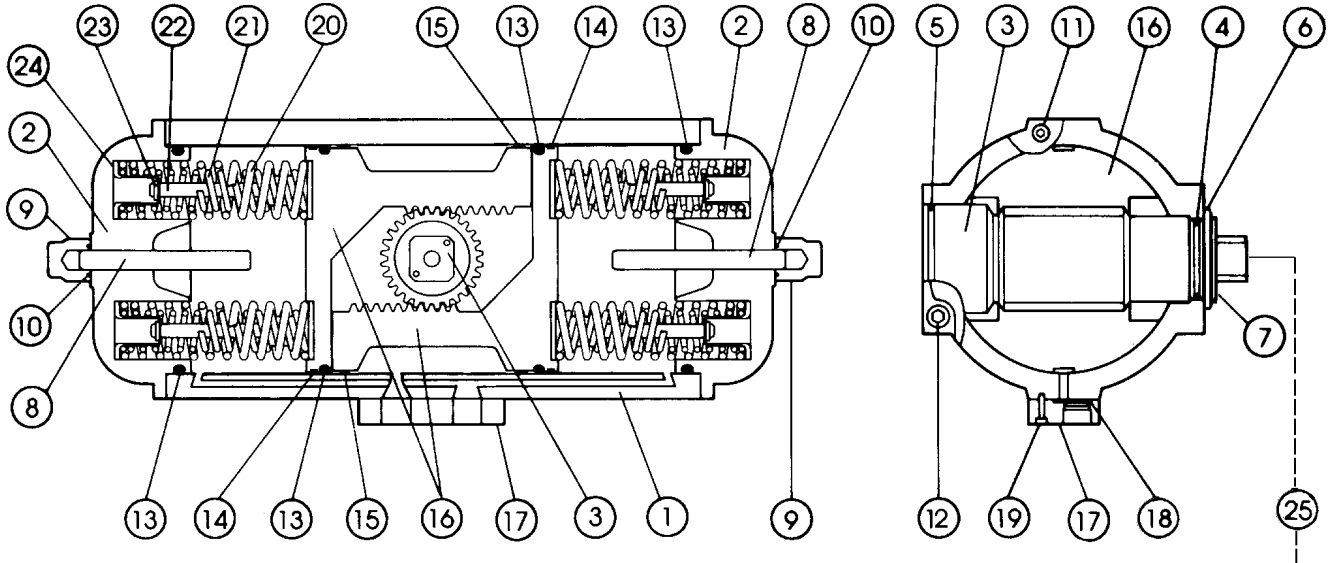

Item No.	Part Description	Qty.	Materials
1	Body	1	Extruded hard anodized aluminum
2	Endcap	2	Die Cast Aluminum. Electrostatic Poly
3	Pinion	1	Nickel Plated Steel
4	Upper pinion 'O'-ring ①	1	Nitrile rubber
5	Lower pinion 'O'-ring ①	1	Nitrile rubber
6	Pinion washer ①	1	Nylon
7	Pinion snap ring ①	1	Steel / plated
8	Stop bolt	2	Steel / plated
9	Stop bolt retaining nut	2	Steel / plated
10	Stop bolt 'O'-ring ①	2	Nitrile rubber
11	Endcap screw	8	Stainless steel
12	Endcap screw	8	Stainless steel
13	Piston and Endcap seal ①	4	Nitrile rubber
14	Piston guide band	2	PTFE
15	Piston guide	2	PTFE
16	Piston	2	Extruded aluminum
17	Connection base	1	Extruded aluminum, anodized
18	Connection base seal ①	2	Nitrile rubber
19	Connection base screw	4	Stainless steel
20	Spring ②	12	Steel electrostatic resin coated
21	Spring ②	12	Steel electrostatic resin coated
22	Spring Cartridge ②	12	Steel / plated
23	Spring Cartridge ②	12	Steel / plated
24	Spring Cartridge ②	12	Steel / plated
25	NAMUR adaptor plate	1	Aluminum / Anodized

Note:

- ① Parts included in a Seal Kit
- ② See Torque Chart for available combinations

SNA250 / SNA300 Seal Kits

Buna Seal Kit Number	NN - (Actuator Model No.) - SK B
Buna Seal Kit Number	NN - (Actuator Model No.) - SK V

Seal kit consists of all sealing parts.

Pressure Rating 150 psig maximum

Temperature Ratings

Standard ¹	Nitrile	-20° F to +175° F
High Temp ²	Viton	0° F to +300° F
Low Temp ²	Silicon-based	-55° F to +175° F

Notes:

- ¹ For standard applications, use multi-purpose polymer fortified grease, such as Dubois Chemicals MPG-2.
- ² For low temperature and high temperature applications, use special formulated grease such as Dow Corning® 55.