Electronic Water Level Gauge

*Installation, Operation
And Maintenance of*

Aquarian 3000M_{ini}



FOSSIL POWER SYSTEMS INC.

10 Mosher Drive
Dartmouth, NS
Canada B3B 1N5

PH# (902) 468-4701 ext 720

FAX# (902) 468-2323

www.fossil.ca

Aquarian 3000M_{ini}

Instruction Manual

9340-1003

Last Modified: May 10, 2006

*Copyright ©2002 Fossil Steam Technologies Inc. All rights reserved.
All trademarks referenced herein are property of their respective corporation.
The information contained herein is subject to change without notice.*

About this Manual

*This instruction manual describes the architecture and operation of the Aquarian 3000 Mini as supplied by **Fossil Power Systems Inc.***

Although care was exercised to make this Manual specific and complete, it is not intended that it and its accompanying equipment manuals should provide for all potential operating and maintenance conditions. It must be recognized that no amount of written instruction can replace intelligent thinking and reasoning on the part of qualified personnel. It is the responsibility of these personnel to become completely familiar with the mechanical, electrical and control systems involved, including their characteristics and performance under various operating conditions.

This knowledge can be obtained through the basic information provided in this manual, supplemented by advice and recommendations from this Company's field agents and by actual experience.

Operation, maintenance and performance of any equipment not furnished by this Company are the sole responsibility of others.

The nature of the electronics, the harsh operation environment and the potential hazards associated with live steam require that only qualified personnel install and maintain the equipment.

Table of Contents

1	INTRODUCTION	1
2	PACKAGING	2
3	INSTALLATION	2
3.1	LOCATION OF THE ELECTRONICS	2
3.2	PRESSURE VESSEL	2
3.2.1	<i>Freeze Damage Precautions.....</i>	3
3.3	PROBES.....	3
3.4	WIRING	3
3.4.1	<i>At the Probes</i>	4
3.4.2	<i>At The Electronic Module.....</i>	4
3.4.3	<i>At the Remote Display Panel</i>	5
3.5	CONTROL OUTPUTS.....	5
3.5.1	<i>Detection Outputs.....</i>	5
3.5.2	<i>Electronics Fault Output</i>	5
3.5.3	<i>Level Fault Output.....</i>	5
4	START-UP AND OPERATION	5
4.1	INDICATING LIGHTS.....	5
4.2	PRESSURE VESSEL	6
4.3	SENSITIVITY CONTROL	6
4.4	SYSTEM MONITOR.....	7
4.4.1	<i>Power Supply Fault</i>	7
4.4.2	<i>Clock Fault</i>	7
4.4.3	<i>Continuity (Open Circuit).....</i>	7
4.4.4	<i>Level Error</i>	8
5	DETECTION THEORY	8
6	MAINTENANCE	8
6.1	PRESSURE VESSEL	8
6.2	PROBES.....	9
6.2.1	<i>Probe Removal</i>	9
6.2.2	<i>Probe Inspection.....</i>	9
6.2.3	<i>Probe Installation.....</i>	10
7	SPARE PARTS.....	11
7.1	INDIVIDUAL PART LIST.....	11
8	SPECIFICATIONS	12

9 AVAILABLE OPTIONS13
9.1 ANALOG 4-20 MA 13

List of Figures

- Figure 1 - Vessel Installation2
- Figure 2 - Probe Assembly3
- Figure 3 - Aquarian 3000 Mini System Wiring 14
- Figure 4 - System Wiring with Junction Box15
- Figure 5 - System Wiring with Junction box and Continuity16
- Figure 6 - Face Plate Label17
- Figure 7 - Jumper Settings18
- Figure 8 - Remote Display Options19
- Figure 9 - Small Display with Junction Box20

installation, operation and maintenance of *Aquarian 3000Mini* electronic water level gauge

1 INTRODUCTION

The Aquarian 3000 Mini satisfies basic level indication needs utilizing vacuum brazed probes for boiler drum, feedwater heaters and other liquid level applications.

It is complete with control outputs and internal system fault monitoring, indication and fault output. The Aquarian system consists of three major components: the column with probes, the detection and verification (D&V) unit, and the remote display.

The electronic system in the D&V unit is connected to 5, 8, 10, 12 or more probes on the water column. The number of probes can be selected and spaced to indicate liquid level through a desired operating range. The Aquarian column is custom manufactured to provide the most accurate indication for any application. Column mounted probes with ceramic insulators have been used and proven reliable for many years of service.

The drawings supplied for each installation specifies the tapping point spacing on the pressure vessel, the number of probes and their positions.

Prior to performing any work, personnel responsible for the installation of the system should read these instructions and become familiar with the unit.

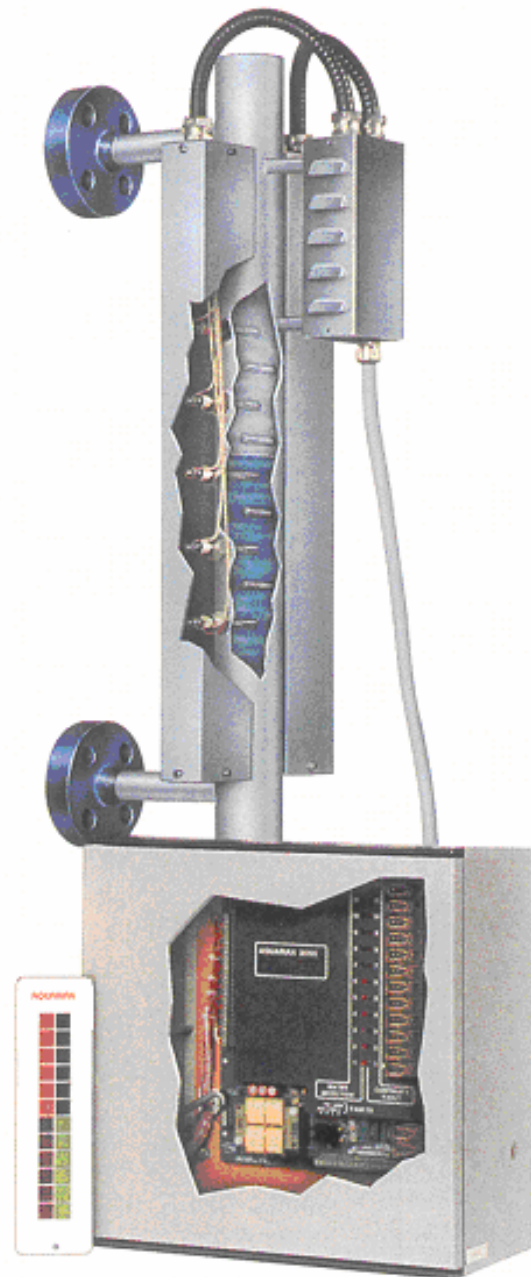

2 PACKAGING

The Aquarian 3000 Mini with the column is packed on one pallet weighing approximately 200 lb (91 Kg). Prior to installing this equipment, clean all packing material from around the unit and inspect for any damage that may have occurred during shipment.

The purchaser must file any claims for loss or damage with the carrier. The manufacturer, on request, will furnish a copy of the bill of lading and freight bill if occasion to file a claim arises.

3 INSTALLATION

3.1 Location of the Electronics

Water with low conductivity requires a higher sensitivity. The highest sensitivity limits the cable distance between probe and electronic module to 65 feet (20m). The intermediate sensitivity places an upper limit of 165 feet (50m) on the cable distance. The lowest sensitivity allows the cable distance to be up to 500 feet (152m). A plug-in module permits selection of the conductivity range of the unit. The highest conductivity mode should be used where possible. The coolest, most accessible location for mounting the electronics is preferred.

3.2 Pressure Vessel

The pressure vessel is fixed to the steam drum either by being welded directly to the isolating valves or welded to flanges that mate to existing flanges on the steam drum tapping points. A steam inlet line must be installed to provide a free flow of steam to the column. Valves in the steam line must be installed with stem horizontal. The steam line must slope down toward the column (a slope of 2% is

recommended). Ideally, the return water leg should be horizontal. This leg may, however, be sloped down to the drum, in which case it must be insulated. In no case should the steam line be insulated.

IMPORTANT Consult the factory if conditions require the use of other types of fittings or special mounting configurations. All welding should be done in accordance with approved procedures as required by applicable specifications. Isolation and blowdown valves should be selected and installed as outlined in the latest edition of the ASME Power Boiler Code, Section 1, and be capable of tight shut-off.

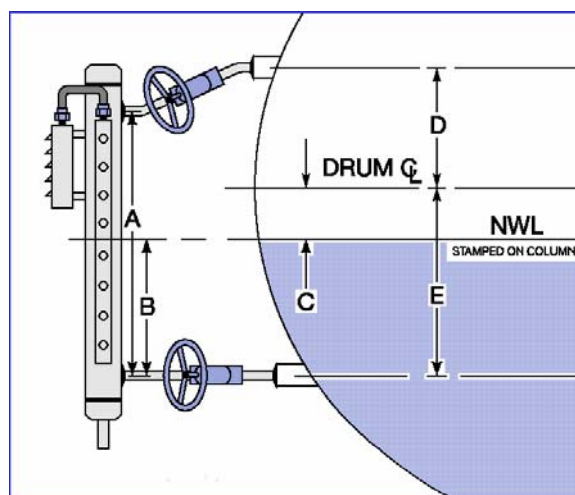

Figure 1 - Vessel Installation

Pressure vessels with three pressure ratings are available – 650psi, 2000psi, and 3000 psi. The material of construction is normally carbon steel, but other materials are available.

The fittings on steam generators of lower pressure usually have a lesser rating. As a result, the rating of the package is governed by the lowest rating of any one of the fittings. Outside applications require a weather shield.

The metal probe shields should be removed and remain off until the system is placed in service and a satisfactory inspection of all the probes and the associated wiring is completed. Refer to Section 3.3 below to install the probe and Swagelok nut.

All screws must be tightened and reinstalled if removed.

If the housing is damaged and cannot be properly secured, it may cause a short circuit and must be replaced.

3.2.1 Freeze Damage Precautions

Installations and locations that may expose the pressure vessel column to low temperatures must take precautions to prevent water in the column from freezing. Water that freezes in the pipe column could damage the probes. Several options to prevent damage include: protecting the column with a heated enclosure, draining water from the column when the boiler is shutdown, and installing insulation with heat tracing. The column junction box should not be insulated since the wire connected to the electronics could be damaged.

3.3 Probes

The Aquarian product is supplied with two models of probes. For applications below 500°F and 650 psi, an economical brazed probe is available. The LP probe is stamped with P/N 9300-0010. For applications above 650psi probe P/N 9300-0002 with the zirconium insulators must be used.



Figure 2 - Probe Assembly

The high-pressure probes have a 0.490-inch diameter body and are easily recognized by the brazing between the insulator and the body. The high-pressure probe can directly retrofit the low-pressure design without any modifications to the receptacle.

IMPORTANT The two probe hex head nuts located on the post used for the electrical connection have been pre-torqued to exact specification prior to shop testing. If the hex head nuts are inadvertently loosened, the probe must be replaced. Probes are supplied fully assembled. Probe receptacles on the pressure vessel are Swagelok fittings.

To ensure the probes remain clean, mount the receptacles such that the probes are exposed to mild fluid circulation. Do not locate the probes in high velocity steam or water. Probes may be located horizontally, or vertically with the electrical connection up.

If it is required to remove a Probe, then refer to Section 6.2 for information on removal, inspection and re-installation.

3.4 Wiring

CAUTION Before making any connections, make sure that the power source to be used is isolated by use of the appropriate circuit breakers and switches so that no work is being performed with "live wires". Do not run input

power through spare conductors in multi-conductor cables used for probe and display panel wiring. Input power is to be run in separate power cables.

All wiring should be in accordance with applicable national and local codes by qualified personnel.

3.4.1 At the Probes

Reference:

- Figure 3 - Aquarian 3000 Mini System Wiring
- Figure 4 - System Wiring with Junction Box
- Figure 5 - System Wiring with Junction box and Continuity

If the Junction Box option is ordered, the unit will be prewired from the probes to the junction box mounted on the column.

The cabling between the junction box and the Electronic Module inside the D&V unit does not require any high temperature capability. It is recommended, however, the cable should have an overall shield, 18-20 gauge tin plated wire and have a rating of 221°F (105°C).

Each electronic module can handle the input from a maximum of twelve probes. Each probe input to the module can have up to two wires, one for probe and one for optional continuity. Ground wires should be connected to the column ground.

The lowermost probe is numbered 1 and the corresponding terminal in the Electronic Module is 1. Wire successively higher probes in the same manner.

IMPORTANT The ring tongue crimp terminal is to be inserted on the probe terminal post between the thumbscrew and the two hex head nuts.

Do not loosen the two hex head nuts.

Do not use excessive force to tighten the thumbscrew.

The probe ground wire is to be connected to the ground screw provided in the probe cover.

These wires should be run to an appropriate junction box. The wire connecting the probes to the electronic module from the junction box should be shielded 18 AWG or 20 AWG stranded, and either tin plated or silver plated copper. **UNPLATED COPPER WIRE SHOULD NOT BE USED.**

3.4.2 At The Electronic Module

Reference:

- Figure 7 - Jumper Setting

For reliable operation, a power source with the following requirements is necessary.

120 VAC or optional 240 VAC
Single Phase, 50/60 Hz
½ Amp / ¼ Amp

Higher voltage will require the use of a stepdown transformer. DC voltages will require use of a voltage inverter.

The jumper is factory set for a supply of 120 VAC unless otherwise stated. For 240 VAC operation, these jumpers have to be relocated.

Make sure the module power up switch is in the "OFF" position. Input power should be connected to the terminals designated "L" (line) and "N" (neutral). The "G" (ground) terminal is internally connected to the metal faceplate and must be connected to a safety ground.

3.4.3 At the Remote Display Panel

Reference:

- Figure 8 - Remote Display Options
- Figure 9 - Small Display with Junction B

The display panel insert is connected to the Detection and Verification Cubicle by an 18 or 20 AWG multi conductor cable. Shielding is required if electrical conductors other than those for the Aquarian's low voltage display share the same wiring conduit.

When several display panels are connected to a single electronic module, each panel can be connected to either the Electronic Module terminal strip or the terminal strip of a preceding display panel. Care must be taken to match the corresponding terminal connections.

Light Emitting Diodes (LEDs) are used on the display panel. These LEDs have an expected 30-year life and can be replaced only on a modular basis.

3.5 Control Outputs

Reference:

- Figure 3 - Aquarian 3000 Mini System Wiring
- Figure 7 - Jumper Setting

3.5.1 Detection Outputs

The control output from each channel is a Form-C type contact. These outputs are designated Relays "1" through "12", for channels 1 to 12, respectively.

These contacts are not fused. Exceeding the rating will shorten the output relays life. As well, incorrect wiring may cause a short circuit and destroy the relay and/or circuit board.

Careful consideration should be given to the design of the alarm and trip logic. Power loss

or vessel blowdown could inadvertently shut down the steam generator or leave the unit without protection.

These contacts can be wired to remote indicators and control circuits as required.

3.5.2 Electronics Fault Output

A Form-C type relay contact is provided to allow external monitoring of the operation of the Aquarian 3000 Mini. This relay is normally energized. Loss of power to the unit or detection of an internal fault condition will cause the relay to de-energize, opening the contacts. The fault detection circuit covers clock failure, continuity failure and two internal power supplies.

3.5.3 Level Fault Output

The Aquarian 3000 Mini is also equipped with a Level Fault relay. This relay is normally de-energized and has a Form-C type output contact (normally open relay contact). See Section 4.4.4 for the explanation of this circuit.

4 START-UP AND OPERATION

Once all connections and wiring are completed, the unit can be placed into service.

4.1 Indicating Lights

Reference:

- Figure 6 - Face Plate Label

The following status indications are displayed on the faceplate:

- PS1 Fault – failure of the first supply.
- PS2 Fault – failure of the second supply.

- Clock Fault – detection circuit clock stopped.
- Water level fault – water/steam inconsistency.
- Water detected – each level has its own indication.
- Probe open circuit fault – each level has its own indication.

4.2 Pressure Vessel

To place the column in service:

Inspect the probes to ensure that the installation and associated wiring are correct. Wiring should be neatly routed and any contact between the high temperature vessel body or the probe cover should be avoided.

Warm up and fill the column as follows:

1. Open the blowdown or vent valve.
2. Crack the steam isolation valve and warm up the vessel for a period of 3 to 5 minutes.
3. At the end of the warm up period, slowly close the blowdown or vent valve and then fully open the steam valve.
4. The water connection isolation valve can now be opened, or alternately, if this valve is left closed, the vessel will fill with condensate allowing the operating range of the device to be verified.
5. The water isolation valve can then be fully opened.
6. Visually check all the probes for any sign of leaks. Replacement of the probe covers using the 1/4" socket head cap screws will complete the commissioning of the vessel.

To take the column out of service:

1. Shut the column isolation valves
2. Crack open the drain valve
3. Verify that all probe levels sequentially indicate "Steam".

Notes:

1. Isolation and blowdown valves should be carefully selected and installed as outlined in the ASME Power Boiler Code, Section 1.
2. During vessel blowdown, isolation, or testing, some form of interlocking bypass of the high and low water control outputs may be required to avoid boiler tripping.

CAUTION Before repairing leaks, ensure the water column is properly isolated from the system, all pressure has been relieved and the unit cooled to an acceptable level.

4.3 Sensitivity Control

Reference:

- Figure 7 - Jumper Setting

Inspect the module to ensure that all electrical connections are made and properly protected. Set the sensitivity required for the water conductivity range to be detected.

The sensitivity setting is determined by the quality of water and distance from the electronics as explained in Section 3.1.

To change the sensitivity, the faceplate must be removed. Next to the probe terminal blocks are four sockets labeled RN1, RN2, RN3 and RN4. Socket RN3 and RN4 are supplied solely to store the spare resistor modules. In these sockets are resistor modules labeled LOW and MEDIUM.

To change sensitivity install the modules as shown in the table below.

Conductivity (micro mho)	RN1	RN2	RN3	RN4
>25	Low	Low	Medium	Medium
>4	Medium	Medium	Low	Low
≥ 0.5	Empty	Empty	Low	Low

All channels will be set to the same conductivity range. The factory default setting is the **medium** conductivity range.

After setting the sensitivity, power may be supplied to the unit by use of the external circuit breaker or main switch. Turn the power-up switch on the module to the "ON" position. The unit is now operational.

4.4 System Monitor

Reference:

- Figure 6 - Face Plate Label
- Figure 7 - Jumper Setting

The Aquarian 3000 Mini is equipped with a fault-annunciating relay that monitors critical internal electronic circuitry. The fault relay is energized and the output contact is closed when no faults are present. If the supply power to the device is lost or if one of the conditions listed below were to occur the fault relay would de-energize and the fault contact would open.

4.4.1 Power Supply Fault

Two separate power supplies (PS1 & PS2) provide logic power for the Aquarian 3000 Mini. The output of both power supplies is diode shared such that if one supply fails, the

remaining supply will carry 100% of the system load.

Caution

Make sure the supply power is isolated before replacing the fuse.

Each supply has a full bridge rectifier, filter and 12-volt voltage rectifier. The two DC supplies share a low voltage transformer with fused input. If a fault were to occur within any part of this circuit the fault circuit would de-energize the fault relay and turn on the PS1 or PS2 LED to indicate the fault area.

If both supplies fail, check the fuse. This can be accomplished by removal of the cover and faceplate of the module, which will expose the fuse.

Replacement fuses should be rated ½ Amp for 120 VAC or ¼ Amp for 240 VAC systems.

4.4.2 Clock Fault

A 1 Hz square wave is used as the timing base for the DC detection circuit.

A failure of the clock circuit will not affect the ability of the device to sense water, although over the long term (3000 hours or more) electroplating will take place. In the short term, therefore, the failure is not serious. If a fault does occur, the clock fault LED will turn on.

4.4.3 Continuity (Open Circuit)

If two signal wires are run to each probe, a cable continuity test can be performed. One wire connects to the "P" (probe) terminal and the other connects to the "C" (continuity)

terminal. The opposite ends of both are wired to the probe. If either wire is broken, a continuity fault occurs for that level, turning on the appropriate light and de-energizing the fault relay. If the break is in the wire connected to the "C" terminal, the level will still show proper steam/water status. If the break is in the wire connected to the "P" terminal, the level will always show steam.

If single wiring only is used, adding 12 wire jumpers on the circuit board can disable the continuity function. Connecting the "C" to the "P" on the terminal strip will also disable this function.

When there is a continuity discrepancy, the continuity fault light for the corresponding level will turn on. However, this indication will automatically be disabled if a clock failure occurs.

4.4.4 Level Error

The Aquarian 3000 Mini is also equipped with a Level Fault relay.

The alarm relay will energize if water is shown over steam. Probe 1 is the lowest, probe 12 is the highest. If any probes are unused, ensure they are the highest probes.

5 DETECTION THEORY

A symmetrical square wave with a period of 1 second is generated in the Aquarian 3000 Mini System. This signal is inputted to each of the detection circuits and, through a resistor, to the probe field terminal blocks.

When the probe tip is immersed in water a current path to ground is completed and the current flow through the circuit causes a voltage differential to appear across a

reference resistor in the electronic module. The voltage is measured at the +VE input of an amplifier and compared to a fixed value at the -VE input of the same amplifier. When the differential exceeds the fixed setting the amplifier outputs a signal indicating the presence of water.

One of three of these fixed settings, or "sensitivities" is selected as explained in Section 4.3 (a lower conductivity water is said to require a higher "sensitivity"). Select the lowest sensitivity that will work with your application. The intermediate or low sensitivity settings increase the maximum cable distance between probe and electronic module to 165 feet (50m) and 500 feet (152m) respectively. Otherwise, the cable distance must be limited to 65 feet (20m).

6 MAINTENANCE

Each boiler installation is subject to varying operating and water conditions. Generally, the higher operating pressure units (>1800 psi or 125 bar) have improved water treatment and maintenance is minimal.

6.1 Pressure Vessel

A specific maintenance program is difficult to detail but the following outlines the minimum required:

1. The vessel should be blown down and visually inspected for leaks every 3 months.
2. The operating range of the device should be verified at this time by allowing the vessel to fill with condensate (see Section IV.2 for Placing Vessel in and out of Service).

6.2 Probes

The voltage to the probes from the electronic cubicle is a square wave of approximately $\pm 5VDC$ with respect to ground; therefore no electrical hazard is present while working on a powered system.

Caution

Before servicing the probes, ensure that the water column is properly isolated from the system, all pressure has been relieved and the unit cooled to an acceptable level.

6.2.1 Probe Removal

1. Establish that the pressure vessel is properly isolated from the steam drum and all pressure has been relieved.
2. Loosen the nut approximately 1 turn and then free the probe to verify all pressure has been relieved. The metal-to-metal sealing surface initially may cause the probe to stick, so carefully free the joint by tapping the probe on the metal body. **Do not strike the alumina insulator and do not use a wrench to turn the probe hex nuts.**
3. After the probe becomes free, loosen the nut fully and remove the probe.

6.2.2 Probe Inspection

The probes should be removed and inspected after the first 12 months. Thereafter, they should be inspected as required, depending upon the degree of problem contamination.

1. Severe deposits on the probes indicate that inspection should be more frequent. A common household powdered cleaner (i.e. COMET) may be used to clean the probe body and the insulator. After cleaning, the probes should be wiped off with a dry, clean cloth (do not immerse the probe in liquids). Probes that show any signs of damage, insulator cracking, or steam leaks must be replaced immediately. Do not attempt disassembly of the probe components.
2. Use an Ohmmeter to check the integrity of the probe. Resistance measurement across the insulator of 5 Meg ohms or greater indicates the probe is in good condition and will continue to perform satisfactory. If the unit is operating in the low sensitivity mode, a resistance value of 500K is acceptable.
3. After the probes have been inspected, cleaned and tested, they can be installed following the steps outlined in the probe installation procedure.
4. Do not leave an open receptacle on the pressure vessel. If for any reason a probe is not immediately re-installed, the port should be plugged with a Swagelok plug No. SS810P (1170-0302), and tightened following the probe installation procedure.
5. The unit can now be placed in service by following the steps outlined in the start-up procedure (Section 4).

6.2.3 Probe Installation

1. Establish that the threads and sealing surfaces are clean.
2. Insert the probe into the receptacle and snug up the Swagelok nut by hand.
3. Tighten with a wrench 1/4 turn only.
4. The threads on the probe receptacle and Swagelok nut should be re-lubricated each time the probe is reinserted.

The recommended anti-seize compounds noted below prevent galling and will lower take-up torque on the threaded parts:

Silver Goop (Swagelok trade name)
MP-50 Moly Paste (Jet Lube of Canada)
Never Seez (trade name)

CAUTION Any malfunction of the equipment should be attended to immediately. Although any single channel will fail safe, the overall package is designed for continued operation. Compounding faults, however, could defeat the internal self-diagnostic logic, providing misinformation to the operator and possibly subjecting the boiler to potential hazard or nuisance trips.

7 SPARE PARTS

The following spare parts are recommended as a minimum set for stocking by the user.

Probe Part No. 9300-0002

1. Stock 2 for a single system in plant
2. Stock 4 for 2 systems in plant
3. Stock 6 for 3 or more systems
4. Maintenance kit, 1 per system

It is also recommended to have a complete electronic module on hand, especially in those plants that have more than one Aquarian 3000 Mini system installed.

7.1 Individual Part List

Description	FST Part Number	Former Yarway Part Number
Electronic Module (no Cubicle) State supply 120VAC or 240VAC	9310-9600	968652-05, 968652-06
Maintenance Kit	9320-0001	968652-01
Remote Display	Please supply system serial number	
Local Display	Please supply system serial number	
4-20 mA Module	9310-9623	
Low Pressure Probe	9300-0010	964584-52
High Pressure Probe	9300-0002	964584-01
Junction Box	9300-2005	964584-05, 964584-22
Junction Box with Continuity	9300-2000	972349-56
High Temperature Wire: One Conductor	6600-0004	965607-**
Two Conductor	6600-0002	969729-**

8 SPECIFICATIONS

Supply Voltage	120 (105-125) VAC 240 (210-250) VAC
Supply Frequency	50-60 Hz
Supply Current	½ Amp @ 120VAC ¼ Amp @ 240VAC
Output Voltage Probes:	± 5 VDC
Relay Contact Rating	8 Amp at 24 VDC (resistive) 10 Amp at 120 VAC (resistive) 1/3 hp at 120 VAC
Operating Temperature Electronics: Column:	32 °F - 140 °F (0 °C - 60 °C) 750 °F (400 °C)
Enclosure Type: Dimensions: Weight:	Nema 4X (IP65) 16" x 16" x 8" 30 lbs (14 Kg)
Wiring Requirement Maximum Distance:	500 ft @ > 25 micro mho 165 ft @ 4 to 25 micro mho 65 ft @ ≥ 0.5 micro mho
D&V Cubicle to Column Junction Box:	18 - 20 AWG shielded 221 °F (105 °C), PVC 12 or 18 conductor, working voltage 300V
D&V Cubicle to Remote Display:	18 - 20 AWG non-shielded 221 °F (105 °C), PVC 25 or 30 conductor, working voltage 300V
Standards:	CSA Approved LR55061 CE, FM, SAQ, ASME Section 1, B31.1 Fossil Steam is an ISO 9002 Registered Company

Specifications and descriptions are subject to change without notice.

9 AVAILABLE OPTIONS

Additional options can be purchased to customize the Aquarian 3000 Mini System to individual applications:

- Door mounted local display
- Panel mount display (reduced size for desk mounting)
- Dual power source relay
- Adjustable trip/alarm time delay
- In service test switch
- Additional remote displays
- Carbon Steel Column 650 psig 500°F
- Chrome-moly column 1660 psig 960°F
- Stainless steel column 2000 psig 750°F
- Stainless steel column 3000 psig 750°F
- Zener barrier for intrinsically safe probe connections
- 4-20mA analog output
- 2000 psi and 3000 psi FM approved systems
- 16, 20, 24 (and up) probe systems

9.1 Analog 4-20 mA

To Order Specify Item Code:

- 9310-9623

The Aquarian 3000 Mini Analog 4-20 mA Module is an intelligent I/O card. It is designed primarily to provide an isolated 4-20 mA output signal. It is configured as a standard two-wire process control current loop.

The output is an analog representation of the height of water in the column. The water height is determined by the existing logic in the Aquarian 3000 Mini system.

Features include:

- An isolated two-wire 4-20 mA industry standard current loop interface.
- Module Alarm contact output.
- Indicators showing power, processor watchdog status and 4-20 mA status.
- Optional independent power supply from the Aquarian Mini.

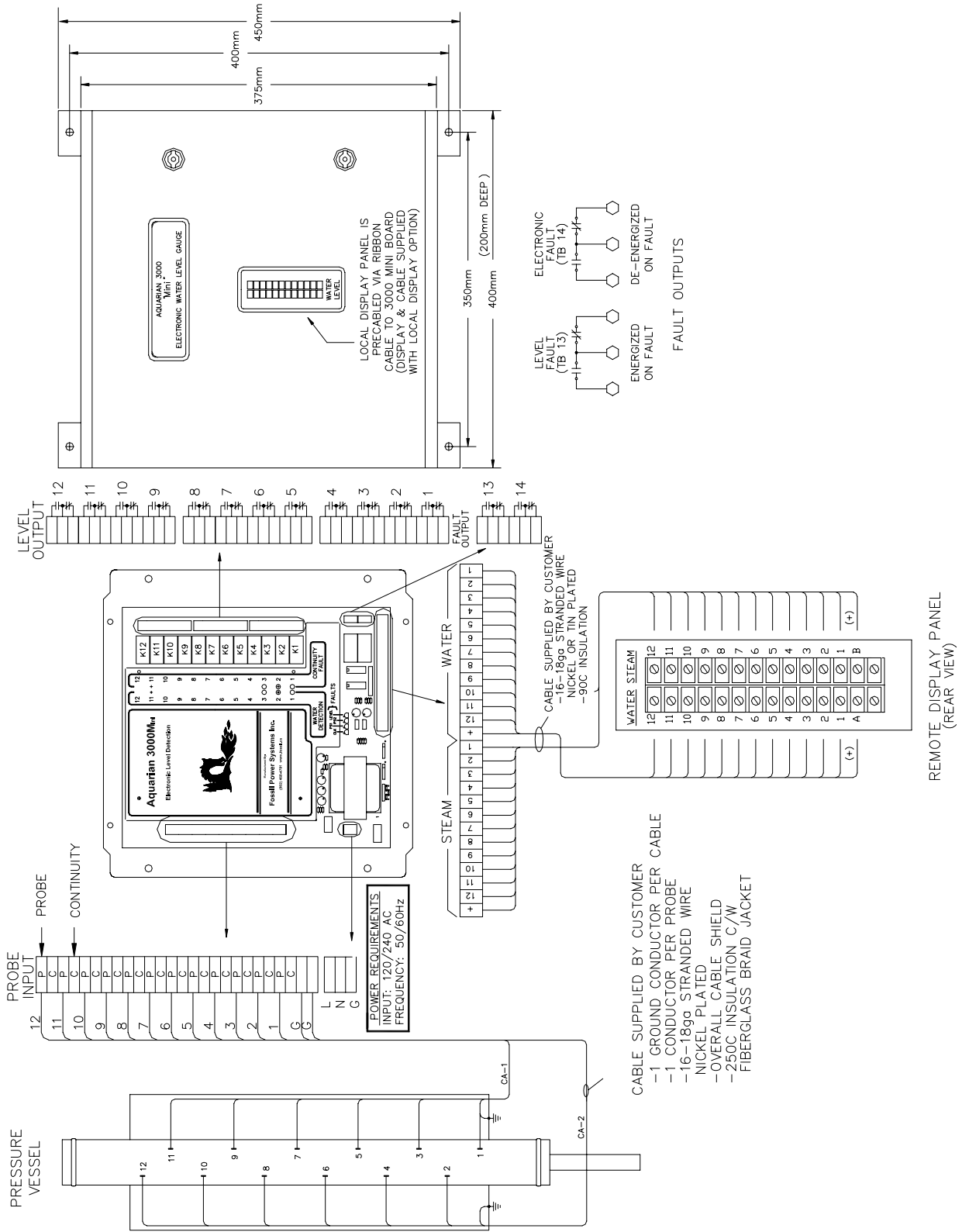

Figure 3 - Aquarian 3000 Mini System Wiring

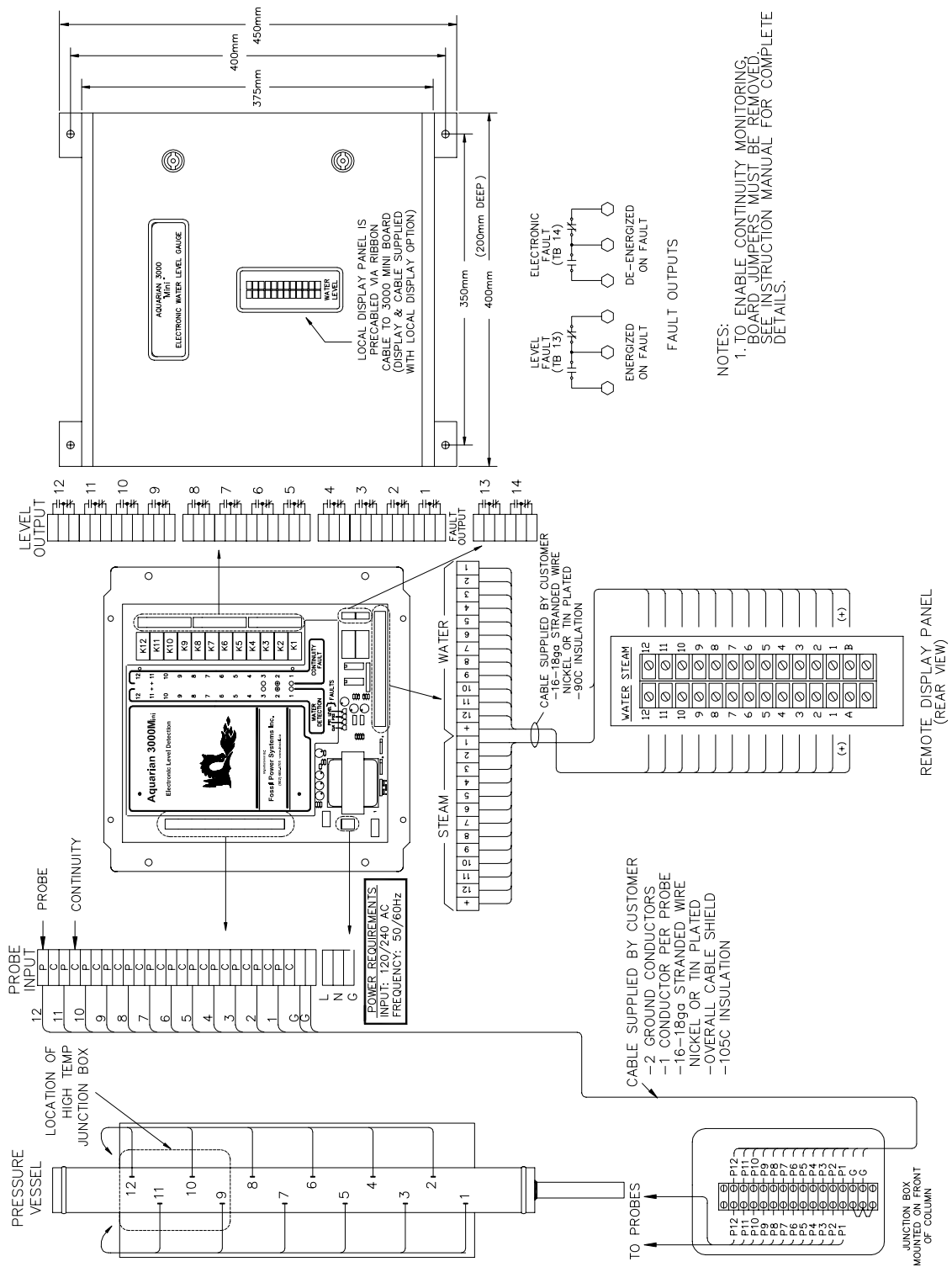

Figure 4 - System Wiring with Junction Box

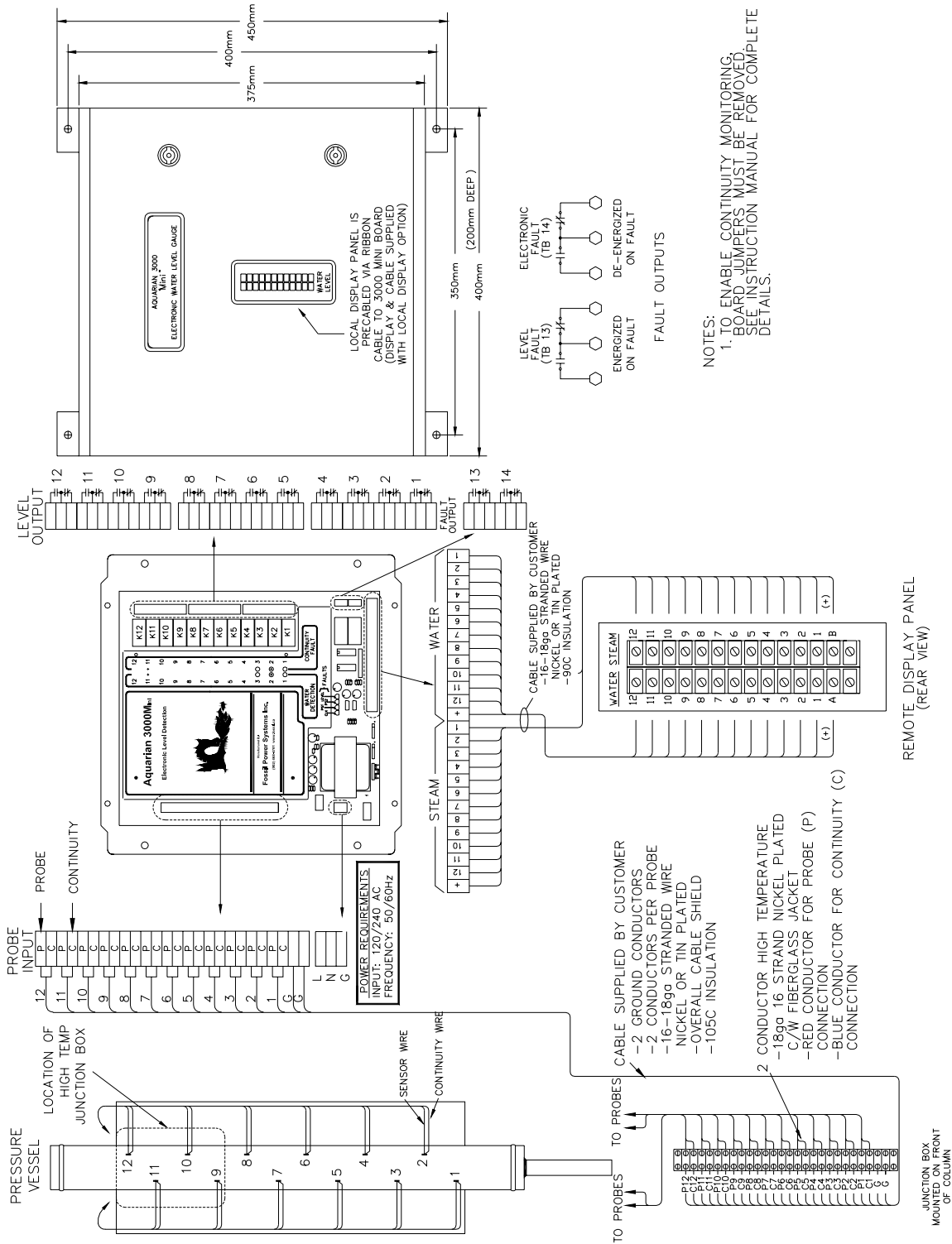

Figure 5 - System Wiring with Junction box and Continuity

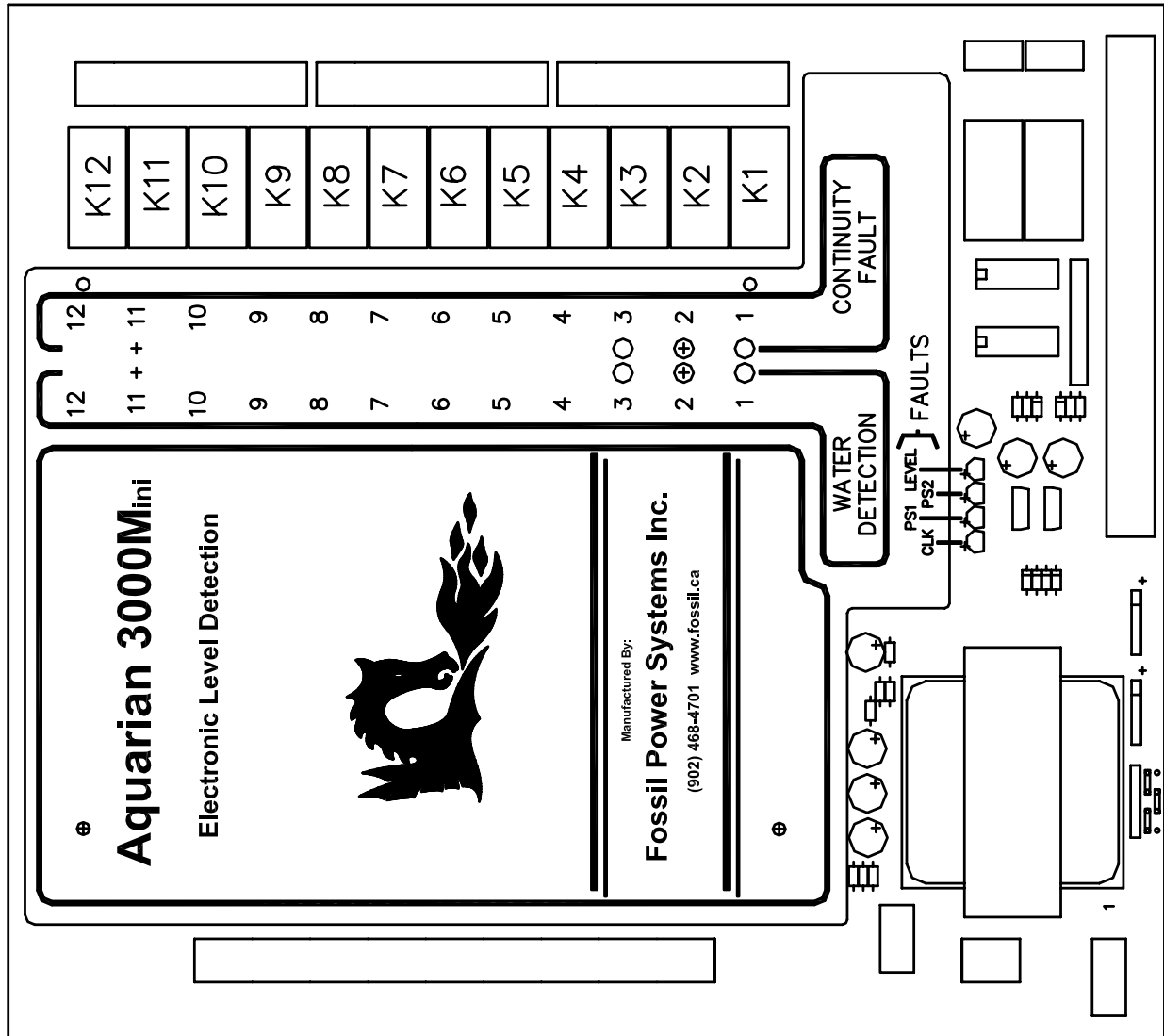

Figure 6 - Face Plate Label

SENSITIVITY SOCKETS

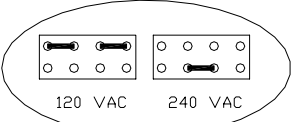
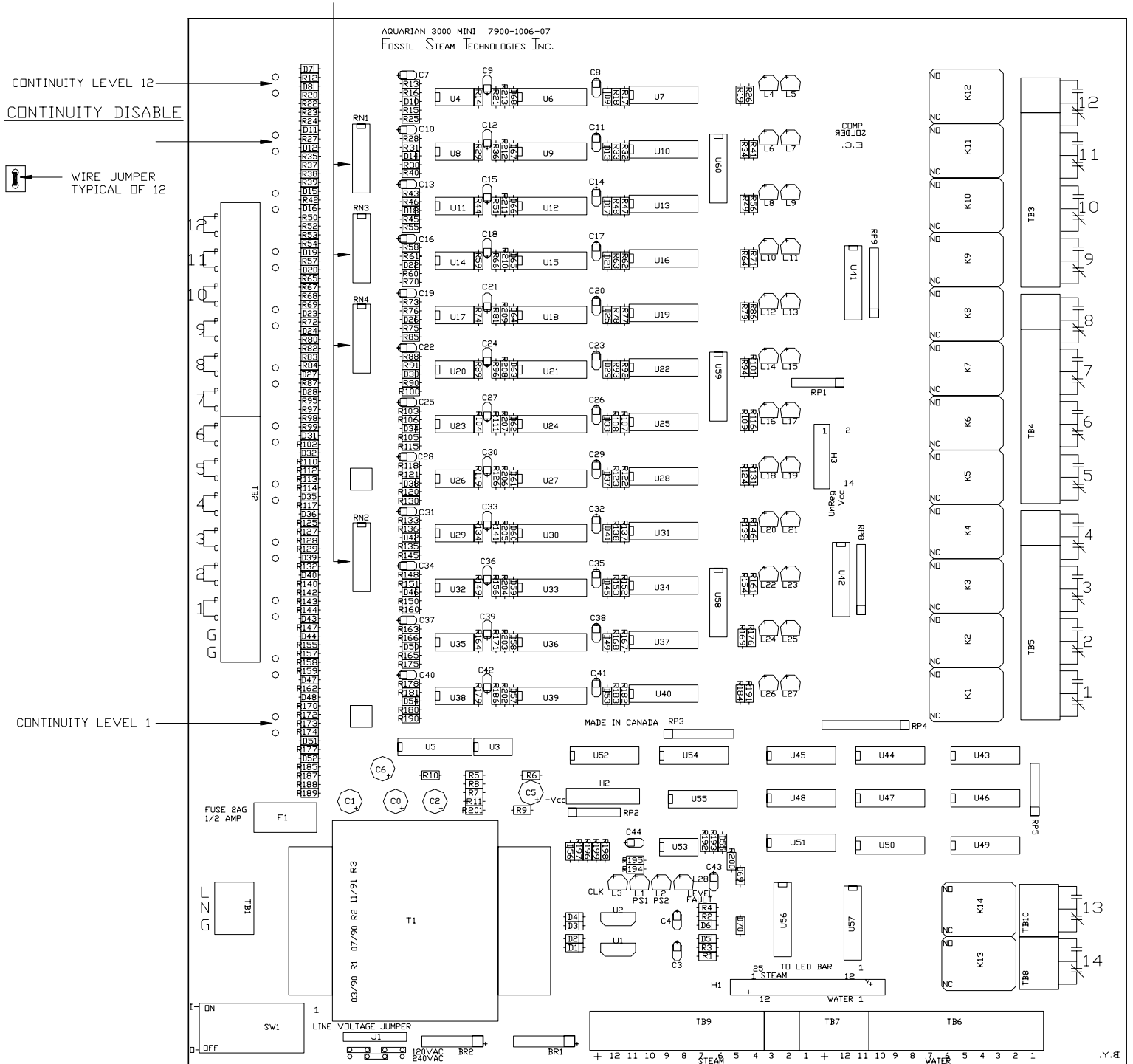

Figure 7 - Jumper Setting

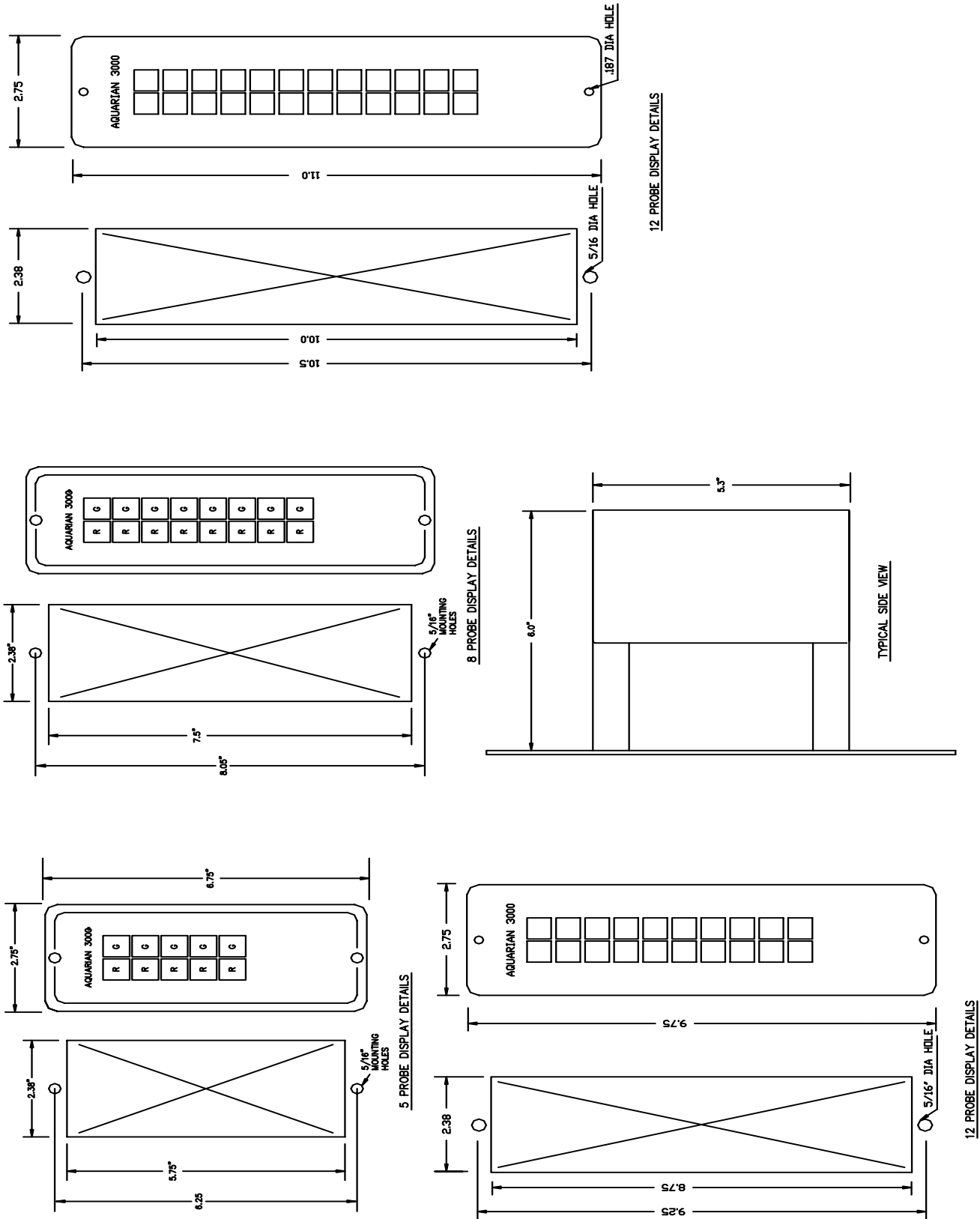

Figure 8 - Remote Display Options

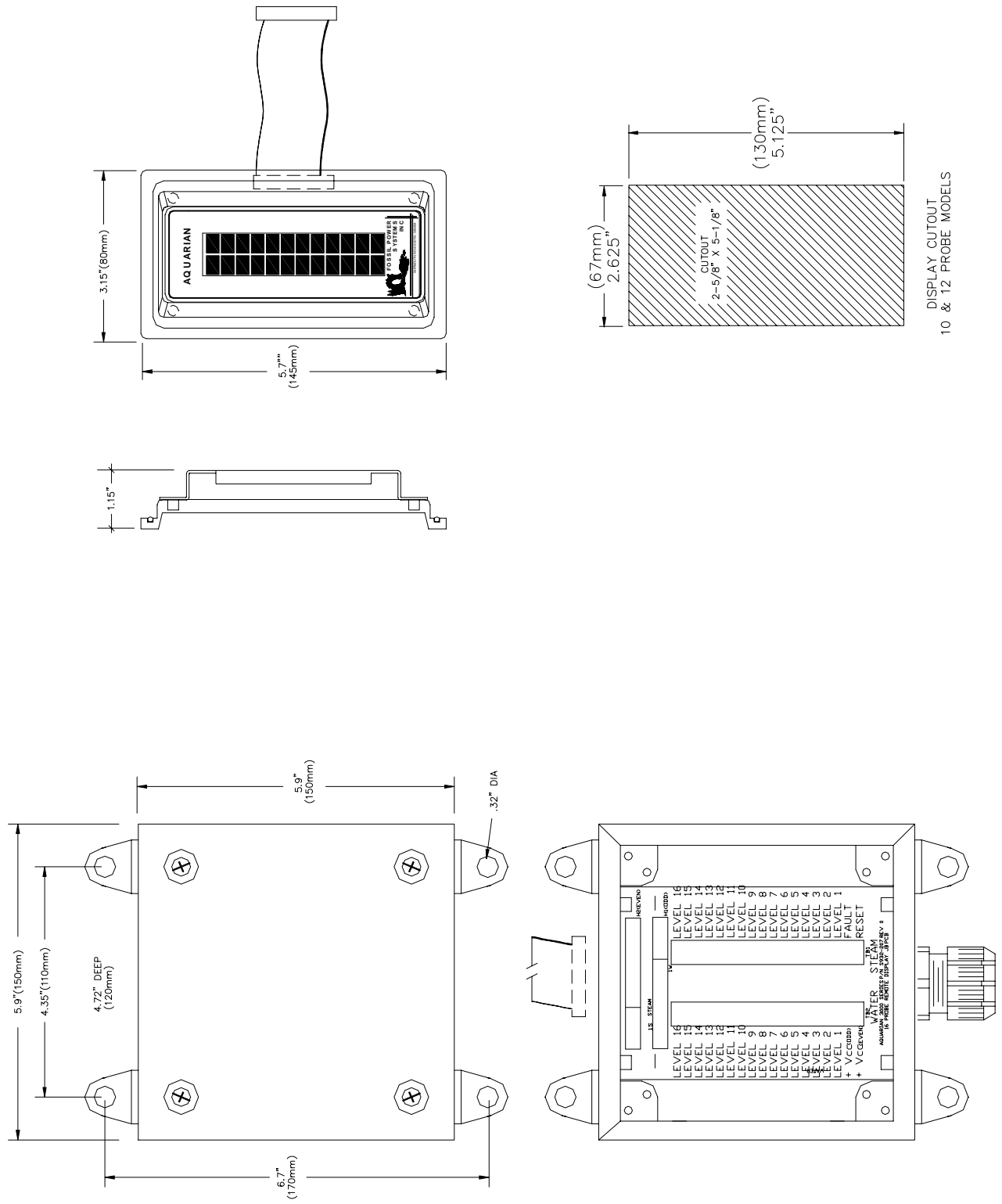

Figure 9 - Small Display with Junction B

REMOTE_DISPLAY

JUNCTION_BOX



Fossil Power Systems Inc.

10 Mosher Drive • Dartmouth, Nova Scotia • Canada B3B 1N5

Phone 902-468-4701 ext 720 • Fax 902-468-2323

email enquiries: aquarian@fossil.ca

www.fossil.ca
