

Valtek CavControl Trim

GENERAL INFORMATION

The following instructions are designed to assist in assembling, disassembling and troubleshooting Valtek® globe valves equipped with CavControl™ trim. Product users should thoroughly review this bulletin in conjunction with Installation, Operation, Maintenance Instruction 1 (Mark One and Mark Two Control Valves) and Installation, Operation, Maintenance Instruction 24 (Valtek Beta Positioner) before installing, operating or performing any maintenance on the valve.

To avoid possible injury to personnel or damage to valve parts, WARNING and CAUTION notes must be strictly followed. Modifying this product, substituting non-factory or inferior parts, or using maintenance procedures other than outlined could drastically affect performance and be hazardous to personnel and equipment.

Installation

Standard unpacking and installation instructions are outlined in Installation, Operation, Maintenance Instruction 1. Regardless of the air-action, valves equipped with CavControl trim must be installed in the line with the flow direction over the plug.

CAUTION: Improper installation will result in severe cavitation damage to the valve.

NOTE: Flowserve recommends a strainer be installed upstream of the valve prior to start-up. This will help prevent debris build-up and trim fouling.

DISASSEMBLY AND REASSEMBLY

Disassembling CavControl Trim

When disassembling valves with CavControl trim, refer to either figure 1 or 2 and proceed as follows:

WARNING: Depressurize line to atmospheric pressure or remove valve from line and drain all process fluids and decontaminate the valve (if caustic or hazardous materials are present). Failure to follow this warning can cause serious injury.

1. Stroke the valve to the full open position by applying air to the lower cylinder port.
2. Remove the bonnet flange bolting and lift the actuator/plug assembly out of the valve body.

CAUTION: Lift the actuator/plug assembly straight out of the valve body to avoid damage to the plug head, seat ring or trim. If the actuator is not provided with a lifting ring, use lifting straps around the yoke legs.

WARNING: With pressure-balanced trim, danger exists in removing the actuator/plug assembly out of the valve body, especially if PTFE pressure seals are used on the plug. The pressure-balanced sleeve could bind on the plug, allowing the sleeve to be lifted out of the body along with the actuator/plug assembly. If the sleeve should loosen and fall, it could cause personal injury and damage valve parts or nearby equipment. Step 3 outlines the correct procedure for removing the sleeve from the plug.

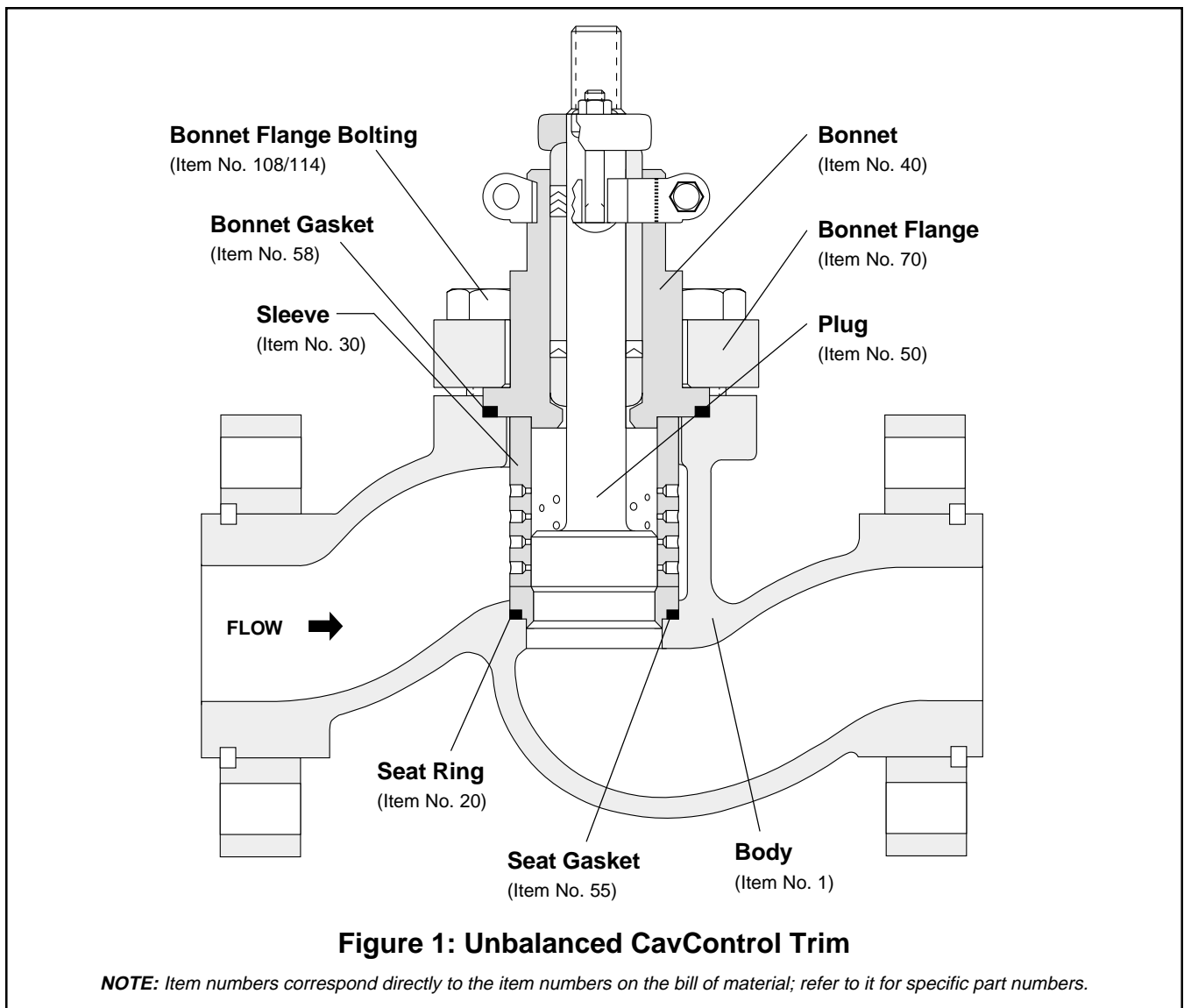

3. If the pressure-balanced sleeve binds with the plug, carefully lift the sleeve out with the actuator/plug assembly. Place several sturdy, soft supports (preferably wood) underneath the sleeve after it clears the body. Lower the actuator/plug assembly until the sleeve and the supports are resting on top of the body.

NOTE: The above procedure is designed to prevent damage to the body should the sleeve fall during disassembly.

To free the sleeve from the plug, apply air above the actuator piston, extending the plug. This creates a gap between the bonnet and sleeve. Insert wood blocks of equal thickness in at least three positions in this gap. Blocks should be at least 1-inch thick and should be positioned so as to not interfere with the plug head. Finally, retract the plug until the sleeve is free of the plug.

4. If the sleeve has not been removed with the plug, lift it out of the valve body.
5. Remove the seat ring and gaskets from the valve body.
6. If the plug is pressure-balanced, remove the plug seals.
7. If necessary, the plug may be removed from the actuator and bonnet in accordance with the basic valve instructions.

Reassembling CavControl Trim

When reassembling valves with CavControl trim, refer to either Figure 1 or 2 and proceed as follows:

1. Install new bonnet and seat ring gaskets.
2. Reinstall seat ring and sleeve.
3. For pressure-balanced trim, install a new sleeve gasket on sleeve and new plug seals on plug head.

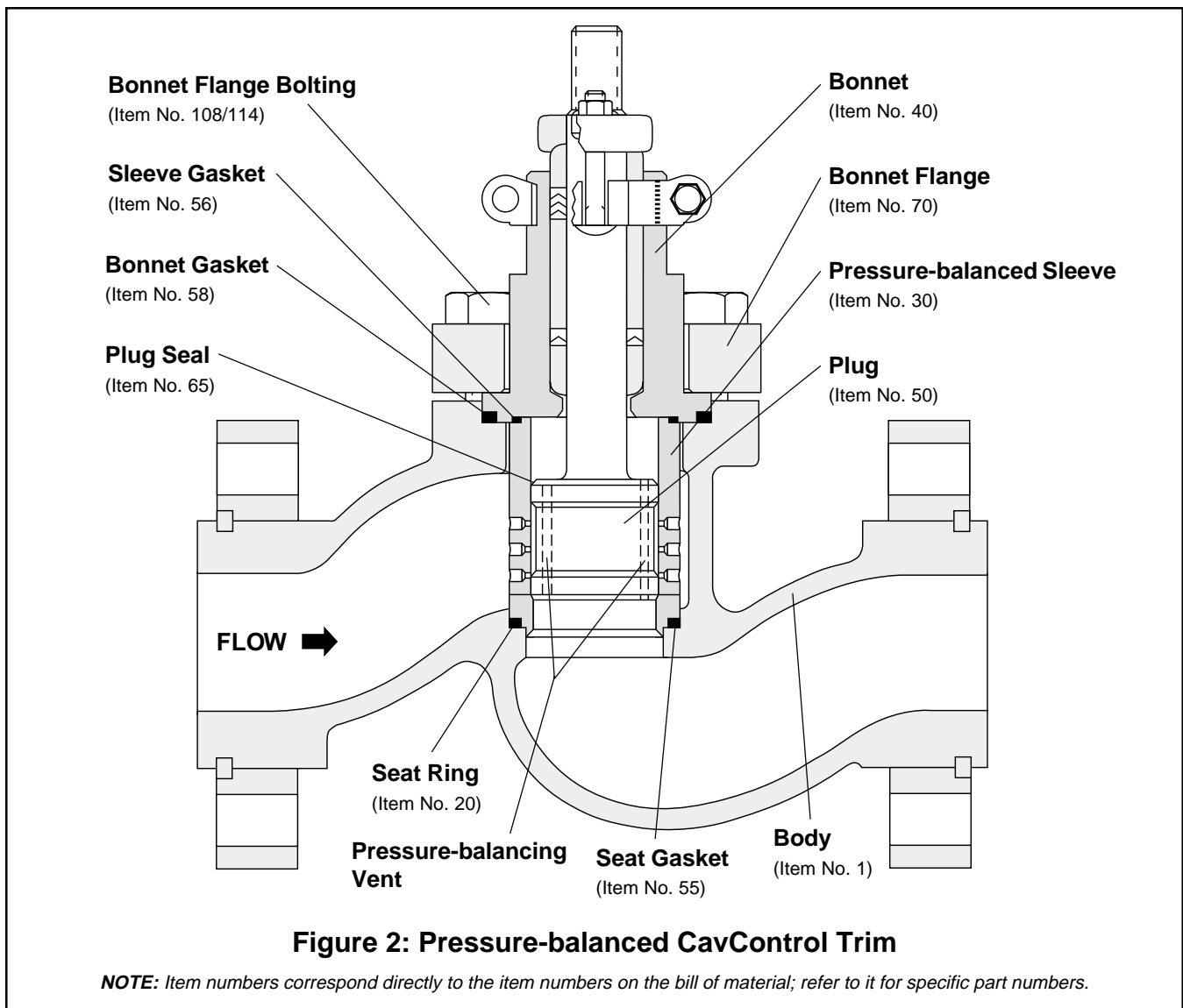

4. Retract plug to the full-open position by applying air to the lower cylinder port.
5. Lower the actuator/plug assembly squarely into the valve body.
CAUTION: Lower plug squarely into sleeve to prevent galling and scoring of trim parts. Plug seals must be compressed, using an appropriate ring compressor, until they enter the pressure-balanced sleeve. Stagger the cuts on the PTFE seals or the gaps on the piston ring seals 180° (for 2 rings) or 120° (for 3 rings) to minimize leakage.
6. Hand-tighten the bonnet flange bolting.
7. For pressure-balanced trim with PTFE seals, drive the plug into the sleeve by applying air to the actuator until the plug seats. Repeat operation, if necessary, to bring the bonnet fully down into the body.
8. Stroke the valve two or three times to ensure that the plug and seat ring are concentrically aligned for proper seating.
9. Apply air pressure above the actuator piston (or to the top port) to seat the plug. This ensures that the plug and seat ring remain concentrically aligned during the tightening of the bonnet flange bolting. Tighten two opposing bonnet flange bolts or nuts $\frac{1}{6}$ of a turn (one flat). Tighten all bolting in this manner evenly and completely. Proper bonnet gasket compression occurs when the bonnet is seated metal-to-metal in the body. This requires considerable force; however, the bottoming of the bonnet metal-to-metal in the body can easily be felt through the wrench.
CAUTION: Insufficient tightening will result in improper seat ring gasket compression.
10. If the valve has been removed from the line, make sure flow direction is correct upon reinstallation.

Troubleshooting Chart

Failure	Probable Cause	Corrective Action
Jerky stem movement	<ol style="list-style-type: none"> Overtightened graphite packing Galling or scoring between plug and sleeve Overtightened packing Service temperature is beyond operating parameter of trim design Inadequate air supply Malfunctioning positioner 	<ol style="list-style-type: none"> Graphite packing is often associated with jerky stem movement Superficial scoring or galling may be removed with a light application of emery cloth; if more serious damage exists, contact factory CAUTION: Trim parts are machined to close tolerances, which are essential for correct functioning of the valve. Attempting to remove deep scratches could result in high leakage rates or improper functioning of the valve Adjust the packing box nuts to just slightly over finger-tight (over-tightening will also cause excessive packing wear and high stem friction) Reconfirm service conditions and contact factory Check for leaks in air supply or instrument signal system; tighten any loose connections and replace any leaking lines Refer to positioner maintenance instruction
Excessive leakage	<ol style="list-style-type: none"> Loose bonnet flange bolting Worn or damaged seat ring Worn or damaged pressure-balanced plug seals Worn or damaged seat, bonnet or sleeve gaskets Inadequate actuator thrust Incorrectly adjusted plug Improper flow direction 	<ol style="list-style-type: none"> Refer to step 9 of "Reassembly" section for correct tightening procedure Disassemble and replace or repair seat ring (for correct procedure on remachining seat surfaces, see Maintenance Instruction 1) Disassemble and replace plug seals Disassemble and replace gaskets Check for adequate air supply to the actuator; if supply is OK, reconfirm service conditions and contact factory Refer to Installation, Operation, Maintenance, Instruction 1 for correct plug adjustment Confirm flow direction is always over the plug
Excessive cavitation damage	<ol style="list-style-type: none"> Worn or damaged plug seals causing excessive trim vibration Misapplication of trim design Improper flow direction Severe corrosive service exceeds trim material limitations 	<ol style="list-style-type: none"> Disassemble and replace plug seals Reconfirm service conditions and contact factory Reinstall with flow direction over the plug Reconfirm service conditions and contact factory
Inadequate flow	<ol style="list-style-type: none"> Improper plug adjustment limiting stroke Malfunctioning positioner Blocked pressure-balanced plug vents or sleeve holes Service conditions exceeding trim design capacity 	<ol style="list-style-type: none"> Refer to Installation, Operation, Maintenance Instruction 1 for correct plug adjustment Refer to positioner maintenance instruction Eliminate matter from line, disassemble and clean plug vents and sleeve Verify service conditions and consult factory
Plug slams	<ol style="list-style-type: none"> Incorrect plug adjustment allowing improper cushion of air between actuator piston and yoke Inadequate air supply Trim sized too large for flow rate 	<ol style="list-style-type: none"> Refer to Maintenance Instruction 1 for correct plug adjustment Check air supply to actuator; repair leaks and remove any restrictions in the supply line Install reduced trim to provide greater plug-to-seat clearance