

Valtek Limit Switches

GENERAL INFORMATION

The following instructions are designed to assist in the adjustment and troubleshooting of limit switches mounted on Valtek automatic control valve actuators. Product users and maintenance personnel should thoroughly review this bulletin in conjunction with the maintenance bulletin for the body style being used.

This bulletin only covers the mechanical aspects of limit switches; therefore, for electrical or internal malfunctions, refer to the appropriate manufacturer's instructions.

To avoid possible injury to personnel or damage to valve parts, WARNING and CAUTION notes must be strictly adhered to.

Limit switches are used to indicate open, closed or intermediate valve plug or disk position or actuator lift. Types supplied conform to NEMA designations and are available in single-pole/double-throw or double-pole/double-throw designs.

Installation

All limit switches are mounted to the actuator using a mounting bracket, mounting screws and special trip tabs. On linear actuators, limit switches are mounted on the yoke leg (see Figure 1). Limit switches installed on rotary actuators are mounted on the transfer case, opposite the positioner (see Figure 2).

Two switches are often specified: One usually indicates the open position and the other usually the closed position. Each switch is activated by a small trip tab as the actuator stem approaches the end of the cycle or stroke. On linear actuators, the trip tab is either bolted or welded to the stem clamp. On rotary actuators, a trip lever is clamped to the valve shaft.

Adjustment

Limit switches are adjusted at the factory before shipment and should not require on-site adjustment. However, if the stem clamp or trip lever has shifted position, the switches may need readjustment. To readjust, proceed as follows:

CAUTION: Before adjusting the switches, if the valve cannot be stroked without disturbing the process fluid, it may be necessary to remove the valve from the line.

WARNING: Prior to removing the valve from the line, depressurize the line to atmospheric pressure, drain all process fluid and (if caustic or hazardous materials are present) decontaminate the valve. Failure to do so can cause serious injury.

1. Check the stem clamp or trip lever to make sure it is securely fastened in the correct position to the stem or shaft respectively.

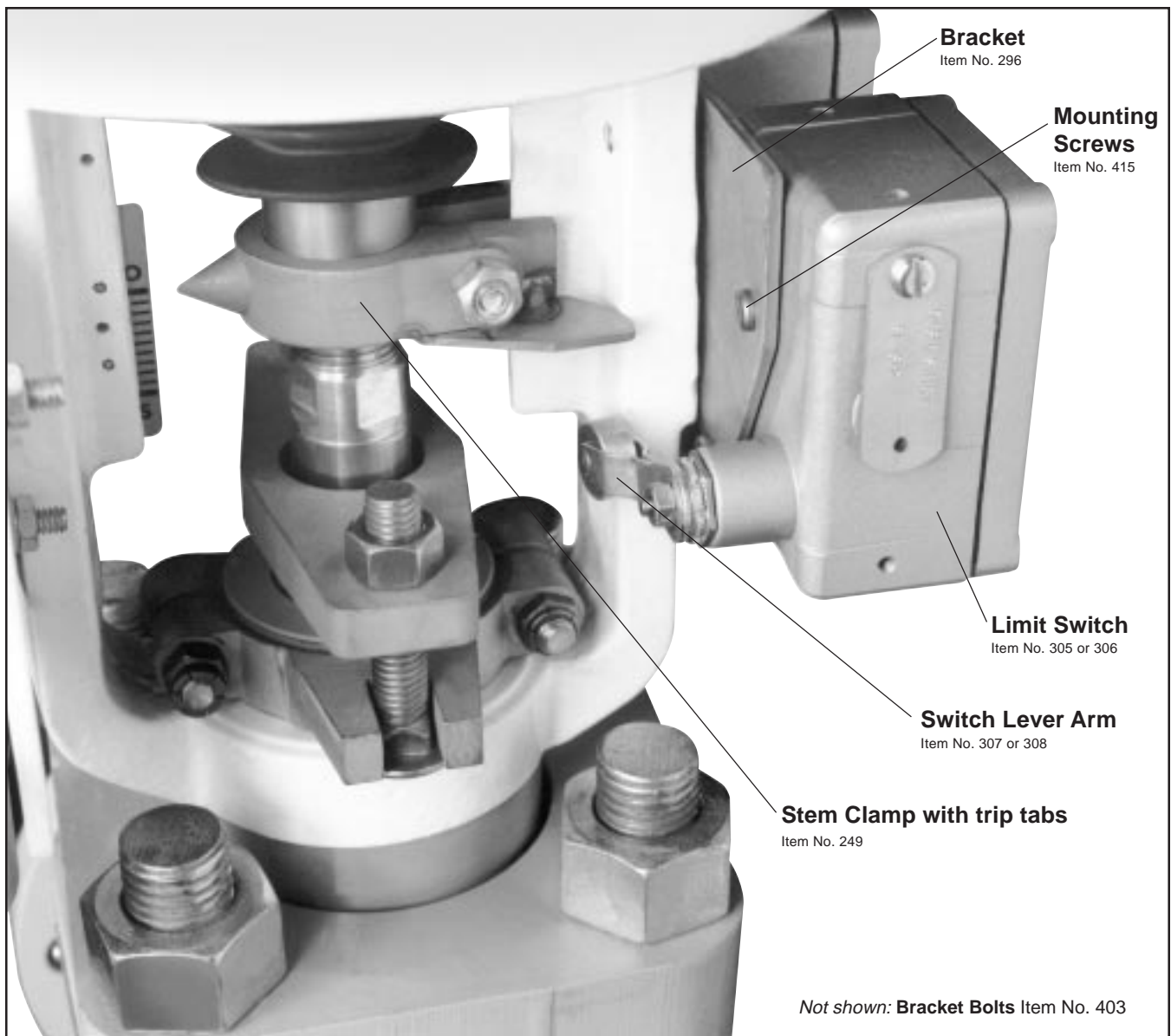

Figure 1: Linear Actuator Limit Switch Mounting

NOTE: Item numbers correspond to those on the bill of material. Refer to bill of material for specific part numbers.

2. Cycle the valve to the position the switch must indicate. Insure mounting bracket bolting is properly tightened.

WARNING: Keep hands, hair, clothing, etc. away from moving parts when operating the valve. Failure to do so can cause serious injury.

3. Loosen the set screw or lock nut on the switch lever arm.

4. Move the switch lever to a position so that the switch is tripped just slightly prior to reaching the position to be indicated. If the switch has a splined shaft to which the lever arm is fastened, rotate the lever arm two more notches on the splined shaft.

5. Retighten the lock nut or set screw.

6. Cycle the valve and check for proper adjustment. Readjust if necessary.

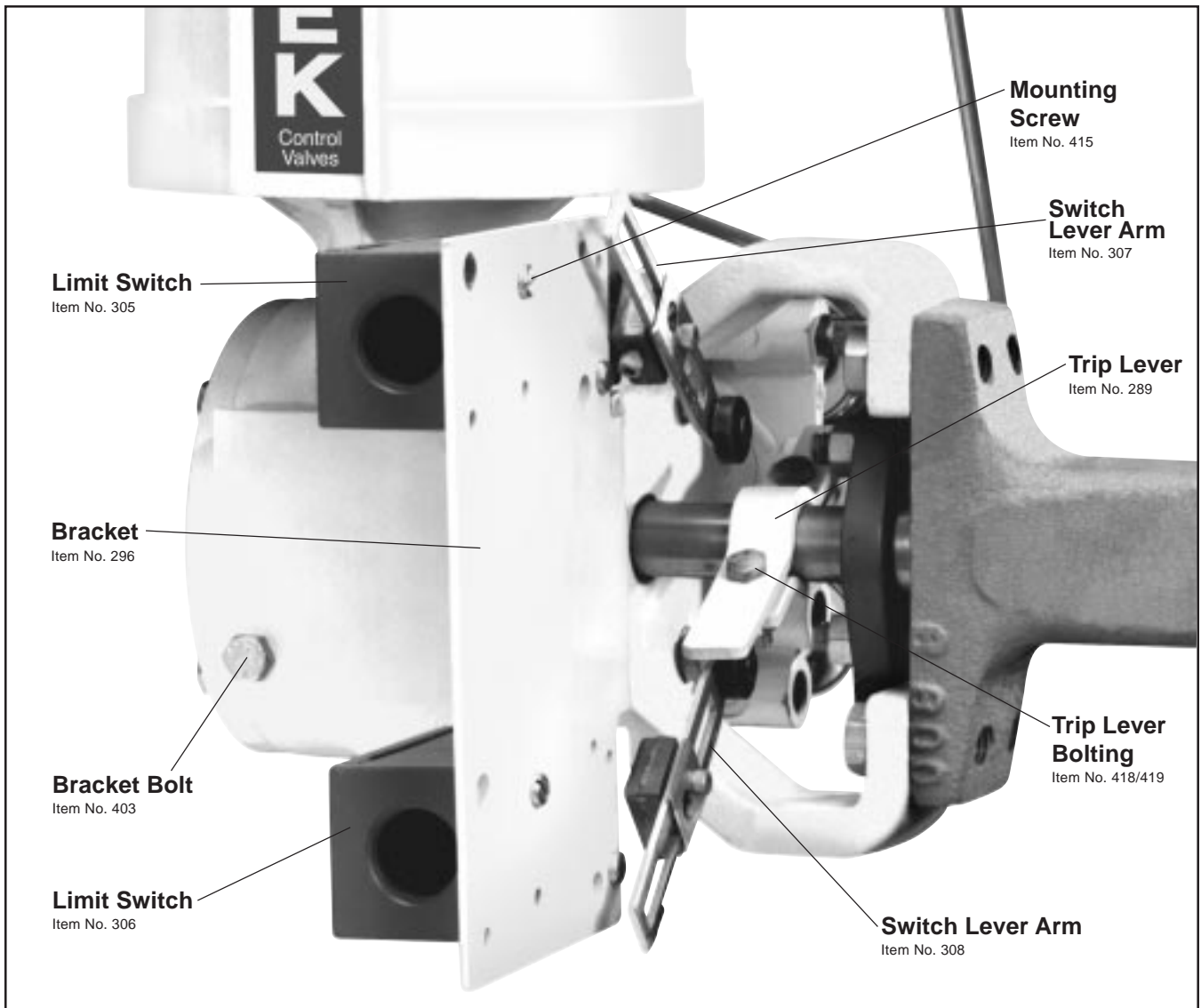

Figure 2: Rotary Actuator Limit Switch

NOTE: Item numbers correspond to those on the bill of material. Refer to bill of material for specific part numbers

Failure	Probable Cause	Corrective Action
Switch operation erratic and inconsistent	1. Loose bracket bolting	1. Tighten bolting holding bracket to yoke leg or transfer case; readjust limit switches
	2. Loose limit switch mounting screws	2. Tighten mounting screws; readjust limit switches
	3. Loose stem clamp (linear actuator) or trip lever (rotary actuator)	3. Tighten stem clamp bolt or trip lever bolting
	4. Internal or electrical malfunction	4. Refer to manufacturer's instructions
Switch operation indicating incorrect position	1. Incorrect adjustment	1. Refer to "Adjustment" section
	2. Internal or electrical malfunction	2. Refer to manufacturer's instructions

Flowserve Corporation has established industry leadership in the design and manufacture of its products. When properly selected, this Flowserve product is designed to perform its intended function safely during its useful life. However, the purchaser or user of Flowserve products should be aware that Flowserve products might be used in numerous applications under a wide variety of industrial service conditions. Although Flowserve can (and often does) provide general guidelines, it cannot provide specific data and warnings for all possible applications. The purchaser/user must therefore assume the ultimate responsibility for the proper sizing and selection, installation, operation and maintenance of Flowserve products. The purchaser/user should read and understand the Installation Operation Maintenance (IOM) instructions included with the product, and train its employees and contractors in the safe use of Flowserve products in connection with the specific application.

While the information and specifications presented in this literature are believed to be accurate, they are supplied for informative purposes only and should not be considered certified or as a guarantee of satisfactory results by reliance thereon. Nothing contained herein is to be construed as a warranty or guarantee, express or implied, regarding any matter with respect to this product. Because Flowserve is continually improving and upgrading its product design, the specifications, dimensions and information contained herein are subject to change without notice. Should any question arise concerning these provisions, the purchaser/user should contact Flowserve Corporation at any of its worldwide operations or offices.

For more information, contact:

For more information about Flowserve and its products, contact www.flowserve.com or call USA 972 443 6500

Manufacturing Facilities

Quick Response Centers

1350 N. Mt. Springs Prkwy.
Springville, UT 84663
Phone 801 489 8611
Facsimile 801 489 3719

5114 Railroad Street
Deer Park, TX 77536 USA
Telephone 281 479 9500
Facsimile 281 479 8511

1300 Parkway View Drive
Pittsburgh, PA 15205 USA
Telephone 412 787 8803
Facsimile 412 787 1944

104 Chelsea Parkway
Boothwyn, PA 19061 USA
Telephone 610 497 8600
Facsimile 610 497 6680

Manderscheidstr. 19
45141 Essen, Germany
Telephone (49) 2 01 89 19 5
Facsimile (49) 2 01 891 9600

Allée du Quartz 1
CH-2300 La Chaux-de-Fonds
Switzerland
Telephone (41) 32 925 9700
Facsimile (41) 32 926 5422

