

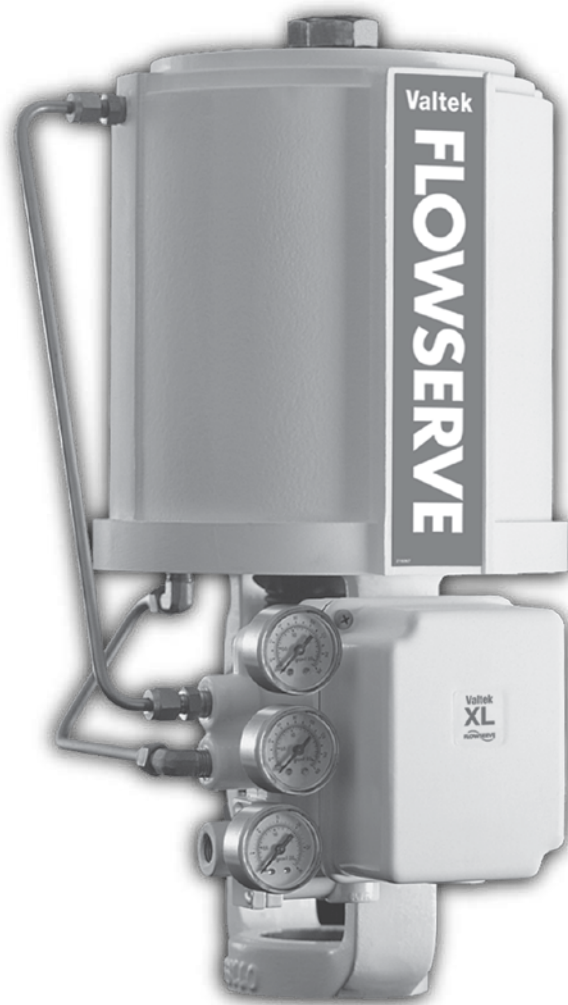

TECHNICAL BULLETIN

Valtek Control Products Spring Cylinder Linear Actuator

FCD VLENTB0002-15 – 04/07



Experience In Motion

Table of Contents

VL Series	3
VL-C Series	4
VL-UHC Series	5
VL-ES Series	6
Cylinder Data	7
Spring Data	8
Manual Handwheel Override Specifications	9
Allowable Cylinder Pressure for Balanced Valves	10
Allowable Cylinder Pressure for Unbalanced Valves	12
Mounting Dimensions, VL, VL-UHC	14
Mounting Dimensions, VL, VL-UHC (Continued)	16
Mounting Dimensions, VL-C, VL-ES	18
Mounting Dimensions, VL-C, VL-ES (Continued)	20
Unbalanced Valve Actuator Dimensions	22

VL Series

The VL series is the standard set of actuators for Valtek control valves, providing precise control and reliable performance. With decades of experience and reliability, VL actuators have been known to be in service for over 30 years. Providing maximum thrust from a compact lightweight package, the VL cylinder has set the industry standard for two generations.

Features and Benefits

Feature	Advantage
Wide Range of Options	A variety of options and accessories allow the VL cylinder to fit into almost any application requiring high thrust and low maintenance.
Compact and Lightweight	Using Aluminum cylinder construction, the VL cylinder is exceptionally compact and lightweight.
Simple Maintenance	Periodic maintenance is easy to perform. VL spring cylinder actuators only requires the removal of two parts to access all internal parts.
Simple Parts	Using standard O-rings for both static and dynamic seals, the VL cylinder actuator soft goods are lower cost and easier to find.

Materials of Construction

Part	Material
Yoke	Phosphated, Painted Ductile Iron
Yoke Clamp	Stainless Steel
Yoke Clamp Bolts	Zinc Plated Steel
Stem Clamp*	Phosphated, Painted Ductile Iron
Cylinder Retaining Ring	Zinc Plated Steel
Actuator Stem	416 Stainless Steel
Stem Spacer	Aluminum
Actuator Stem Lock Nut	Zinc Plated Steel
O-Rings	Buna-N
Spring	Alloy Steel
Spring Button	Painted Steel
Adjusting Screw	Zinc Plated Steel
Piston	Anodized Aluminum
Bushings	Bronze, Oilite
Cylinder	Painted Anodized Aluminum

*Stainless Steel material on 25 and 50 square inch

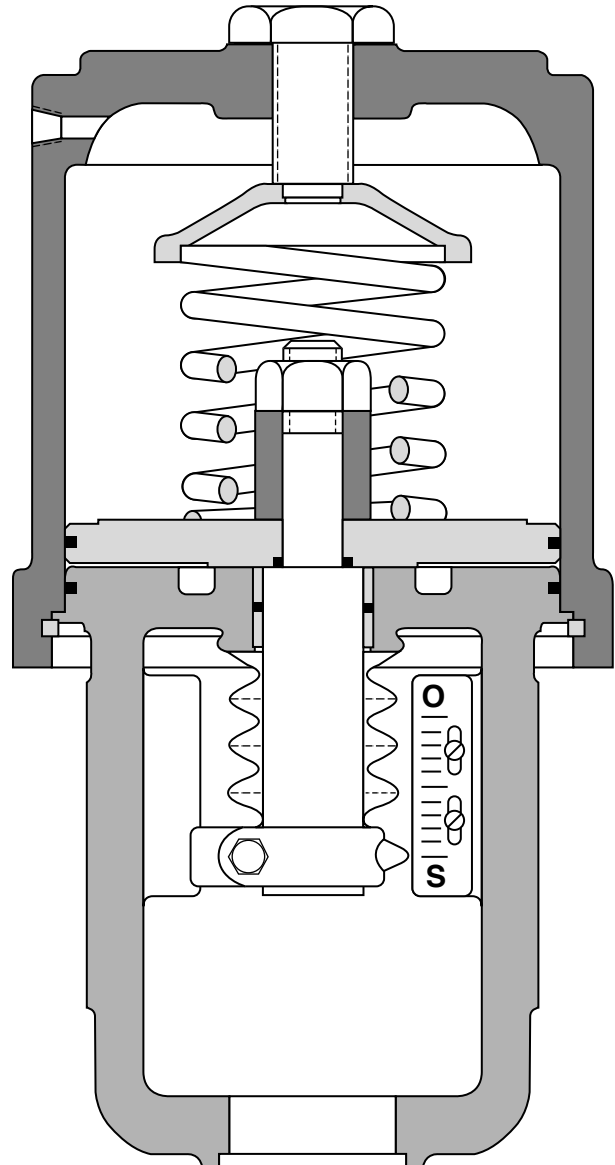

VL-C Series

For applications where aluminum materials are not acceptable, Flowserve offers the compact, lightweight and high thrust of the VL-C carbon steel spring cylinder linear actuator. Offering identical springs and all the advantages of VL actuators, the VL-C actuator replaces all aluminum parts with carbon steel.

Offered in two styles, the size 25 and 50 square inch actuators use deep drawn cylinders while the size 100, 150, 200, 300 and 400 offers tie rod construction.

Materials of Construction

Part	Material	
	Size 25 and 50	Size 100 and Larger
Yoke	Phosphated, Painted Ductile Iron	Phosphated, Painted Ductile Iron
Yoke Clamp	Stainless Steel	Stainless Steel
Yoke Clamp Bolts	Zinc Plated Steel	Zinc Plated Steel
Stem Clamp*	Stainless Steel	Phosphated, Painted Ductile Iron
Cylinder Retaining Ring	Zinc Plated Steel	—
Tie Rods and Nuts	—	Carbon Steel
Actuator Stem	416 Stainless Steel	416 Stainless Steel
Stem Spacer	Carbon Steel	Carbon Steel
Actuator Stem Lock Nut	Zinc Plated Steel	Zinc Plated Steel
O-Rings	Buna-N	Buna-N
Quad Seals	—	Buna-N
Spring	Alloy Steel	Alloy Steel
Spring Button	Carbon Steel	Carbon Steel
Adjusting Screw	Zinc Plated Steel	Zinc Plated Steel
Piston	Carbon Steel	Carbon Steel
Bushings	Bronze, Oilite	Bronze, Oilite
Cylinder	Zinc Plated, Painted Carbon Steel	Painted Carbon Steel
End Cap	—	Painted Carbon Steel

*Stainless steel material on 25 and 50 square inch.



Features and Benefits

Feature	Advantage
Carbon Steel Construction	Replaces all aluminum parts with carbon steel.
Simple maintenance	Periodic maintenance is easy to perform. VL-C spring cylinder actuator sizes 25 and 50 only requires the removal of two parts to access all internal parts.
Simple Parts	Using standard O-rings for both static and dynamic seals, the VL cylinder actuator soft goods are lower cost and easier to find.

VL-UHC Series

For applications where ultra high cycle (UHC) life is needed, Flowserve offers the exceptionally long cycle of the VL-UHC series actuators. By replacing or modifying several parts used in the standard VL series actuator, the VL-UHC gains cycle lives previously thought unattainable.

Features and Benefits

Feature	Advantage
Life Cycles	Expected lifespan of up to 2 million cycles!
Dynamic Quad Seals	All dynamic seals are quad seal design. This provides better lubrication and much longer life.
Plug Stem Jam Nut	Providing better alignment of the actuator stem and plug stem, the jam nut lengthens the life span of the bushings.
Same Simple Maintenance	Periodic maintenance is easy to perform. VL-UHC spring cylinder actuator only requires the removal of two parts to access all internal parts.
Recessed Adjusting Screw O-ring	Providing better alignment and sure sealing, the recessed adjusting screw O-ring lengthens the life of the actuator.
Thrust Bearing for the Spring	Thrust bearings prevent windup on the spring, lowering the stresses in the spring and giving it longer life.
Special Springs	Special springs with stronger materials and better finishes provide exceptionally long life spans.

Expected Life Cycles

Actuator Size	Standard Design ¹	UHC Design ²
25, Standard	500,000	2,000,000
25, Dual Spring	300,000	2,000,000
50, Standard	300,000	2,000,000
50, Extended	300,000	2,000,000
50, Dual Spring	300,000	2,000,000
100, Standard	300,000	2,000,000
100, Heavy Duty	150,000	2,000,000
100, Dual	150,000	2,000,000
200, Standard	300,000	2,000,000
200, Heavy Duty	150,000	2,000,000
200, Dual	150,000	2,000,000

1) Soft Goods should be replaced every 100,000 cycles

2) Soft goods should be replaced every 500,000 cycles



Materials of Construction

Part	Material
Yoke	Phosphated, Painted Ductile Iron
Yoke Clamp	Stainless Steel
Yoke Clamp Bolts	Zinc Plated Steel
Stem Clamp*	Phosphated, Painted Ductile Iron
Cylinder Retaining Ring	Zinc Plated Steel
Actuator Stem	416 Stainless Steel
Stem Spacer	Aluminum
Actuator Stem Lock Nut	Zinc Plated Steel
O-Rings	Buna-N
Quad Seals	Buna-N
Spring	Alloy Steel
Spring Button	Painted Steel
Adjusting Screw	Zinc Plated Steel
Piston	Anodized Aluminum
Bushings	Bronze, Oilite
Jam Nut	Zinc Plated Steel
Thrust Bearing	Delrin
Cylinder	Painted Anodized Aluminum

*Stainless Steel material on 25 and 50 square inch

VL-ES Series

Materials of Construction

Part	Material
Yoke	Phosphated, Painted Ductile Iron
Yoke Clamp	Stainless Steel
Yoke Clamp Bolts	Zinc Plated Steel
Stem Clamp	Phosphated, Painted Ductile Iron
Tie Rods and Nuts	Carbon Steel
Actuator Stem	416 Stainless Steel
Spring Connecting Rod	416 Stainless Steel
Actuator Stem Lock Nut	Zinc Plated Steel
O-Rings	Buna-N
Quad Seals	Buna-N
Spring	Alloy Steel
Spring Housing	Painted Carbon Steel
Spring Buttons	Carbon Steel
Spring Cap Bolting	Zinc Plated Steel
Piston	Anodized Aluminum
Bushings	Bronze, Oilite
Thrust Bearing	Delrin
Cylinder	Painted Carbon Steel
End Cap	Painted Carbon Steel

Features and Benefits

Feature	Advantage
Life Cycles	Expected lifespan of up to 2 million cycles!
Dynamic Quad Seals	All dynamic seals are quad seal design. This provides better lubrication and much longer life.
Plug Stem Jam Nut	Providing better alignment of the actuator stem and plug stem, the jam nut lengthens the life span of the bushings.
Same Simple Maintenance	Periodic maintenance is easy to perform. VL-UHC spring cylinder actuator only requires the removal of two parts to access all internal parts.
Thrust Bearing for the Spring	Thrust bearings prevent windup on the spring, lowering the stresses in the spring and giving it longer life.
Special Springs	Special springs with stronger materials and better finishes provide exceptionally long life spans.

For applications where longer strokes or unusually high spring thrusts are required, Flowserve offers the VL-ES series actuators. Using many of the same design concepts as the VL-C, the VL-ES offers external spring cans. This allows for extra long springs which provide longer stroke lengths and extra force.



Cylinder Data

Actuator Design	Cylinder Size	Cylinder Bore Diameter		Upper Cylinder Area (in ²)		Lower Cylinder Area (in ²)		Stem Diameter (in.)		Stem Area (in ²)		Max. Vol. Over Piston (in ³)		Breakout Friction	
		in.	mm	in ²	cm ²	in ²	cm ²	in.	mm	in ²	cm ²	in ³	cm ³	lb	N
VL	25	5.50	140	23.76	153.3	22.97	148.19	1.00	25.4	0.79	5.10	100	1639	11.5	51
	50 ⁽¹⁾	7.75	197	47.17	304.3	46.39	299.29	1.00	25.4	0.79	5.10	331	5424	16.1	72
	50	7.75	197	47.17	304.3	45.67	294.64	1.38	35.1	1.50	9.68	331	5424	16.1	72
	100 ⁽¹⁾	11.00	279	95.03	613.1	93.26	601.68	1.50	38.1	1.77	11.42	1031	16895	23.4	104
	100	11.00	279	95.03	613.1	91.06	587.48	2.25	57.2	3.98	25.68	1031	16895	23.4	104
	200	15.50	394	188.70	1217.4	184.70	1191.61	2.25	57.2	3.98	25.68	2087	34200	31.4	140
	300	19.50	495	298.60	1926.4	292.70	1888.38	2.75	69.9	5.94	38.32	3733	61173	39.4	175
	400 ⁽²⁾	15.50	394	371.50	2396.8	365.50	2358.06	2.75	69.9	5.94	38.32	3033	49702	43.3	193
	500	25.25	641	500.70	3230.3	494.80	3192.25	2.75	69.9	5.94	38.32	5519	90440	49.5	221
	600 ⁽²⁾	19.50	495	590.20	3807.7	583.10	3761.93	3.00	76.2	7.07	45.61	5661	92767	53.8	239
VL-C	25	5.50	140	23.76	153.3	22.97	148.19	1.00	25.4	0.79	5.10	100	1639	11.5	51
	50 ⁽¹⁾	7.75	197	47.17	304.3	46.39	299.29	1.00	25.4	0.79	5.10	331	5424	16.1	72
	50	7.75	197	47.17	304.3	45.67	294.64	1.38	35.1	1.50	9.68	331	5424	16.1	72
	100 ⁽¹⁾	12.00	305	113.00	729.0	111.00	716.13	1.50	38.1	1.77	11.42	1300	21303	25.2	130
	100	12.00	305	113.00	729.0	109.00	703.22	2.25	57.2	4.00	25.81	1300	21303	25.2	130
	150	14.00	356	154.00	993.5	150.00	967.74	2.25	57.2	4.00	25.81	1783	29218	28.7	146
	200	16.00	406	201.00	1296.8	197.00	1270.97	2.25	57.2	4.00	25.81	2384	39067	32.3	161
VL-ES	100	12.00	305	109.00	703.2	109.00	703.22	2.25	57.2	3.98	25.68	(Note 3)	(Note 3)	29.2	130
	150	14.00	356	150.00	967.7	150.00	967.74	2.25	57.2	3.98	25.68	(Note 3)	(Note 3)	32.7	146
	200	16.00	406	197.00	1271.0	197.00	1270.97	2.25	57.2	3.98	25.68	(Note 3)	(Note 3)	36.3	161
	300	20.00	508	308.30	1989.0	308.30	1989.03	2.75	69.9	5.94	38.32	(Note 3)	(Note 3)	43.3	193
	400	22.00	559	374.20	2414.2	374.20	2414.19	2.75	69.9	5.94	38.32	(Note 3)	(Note 3)	46.9	209
VL-UHC	25	5.50	140	23.76	153.3	22.97	148.19	1.00	25.4	0.79	5.10	100	1639	11.5	51
	50 ⁽¹⁾	7.75	197	47.17	304.3	46.39	299.29	1.00	25.4	0.79	5.10	331	5424	16.1	72
	50	7.75	197	47.17	304.3	45.67	294.64	1.38	35.1	1.50	9.68	331	5424	16.1	72
	100 ⁽¹⁾	11.00	279	95.03	613.1	93.26	601.68	1.50	38.1	1.77	11.42	1031	16895	23.4	104
	100	11.00	279	95.03	613.1	91.06	587.48	2.25	57.2	3.98	25.68	1031	16895	23.4	104
	200	15.50	394	188.70	1217.4	184.70	1191.61	2.25	57.2	3.98	25.68	2087	34200	31.4	140

(1) Used as oversized actuators in place of the next size smaller actuator

(2) Tandem, double piston configuration

(3) Maximum volume over the piston = (Cylinder Area - Stem Area)*(Stroke Length + 0.375 inch)

Spring Data

Actuator Design	Cylinder Size	Spring Design	Stroke	Air-to-Open (Air-to-Retract)				Air-to-Close (Air-to-Extend)			
				Spring Compressed Force		Spring Rate		Spring Compressed Force		Spring Rate	
				in	lb	N	lb	N	lb	N	lb
VL	25	Standard	0.75 to 1.50	416	1850	189	841	450	2002	189	841
		Dual	0.75	964	4288	456	2028	--	--	--	--
			1.00 to 1.50	1075	4782	456	2028	--	--	--	--
	50	Standard	1.5 to 3.00	615	2736	164	730	656	2918	164	730
		Dual	1.5 to 3.00	1864	8291	447	1988	--	--	--	--
	100 Through 600	Standard	2.00 to 4.00	1725	7019	300	1334	1725	7544	300	1334
		Heavy	2.00 to 4.00	3168	14092	535	2380	3168	14092	535	2380
		Dual	2.00 to 4.00	5241	23313	885	3937	--	--	--	--
	VL-C	25	Standard	0.75 to 1.50	416	1850	189	841	450	2002	189
Dual			0.75	964	4288	456	2028	--	--	--	--
			1.00 to 1.50	1075	4782	456	2028	--	--	--	--
50		Standard	1.5 to 3.00	615	2736	164	730	656	2918	164	730
		Dual	1.5 to 3.00	1864	8291	447	1988	--	--	--	--
100 Through 200		Standard	2.00 to 4.00	1725	7019	300	1334	1725	7544	300	1334
		Heavy	2.00 to 4.00	3168	14092	535	2380	3168	14092	535	2380
		Dual	2.00 to 4.00	5241	23313	885	3937	--	--	--	--
VL-ES		100	Standard	2.5 to 4	3000	13345	300	1334	3000	13345	300
	5 to 8			3014	13407	182	810	3014	13407	182	810
	150	Standard	2.5 to 4	3000	13345	300	1334	3000	13345	300	1334
			5 to 8	3014	13407	182	810	3014	13407	182	810
		Heavy	2.5 to 4	6023	26752	771	3430	6014	26752	771	3430
			5 to 8	6524	29020	434	1931	6524	29020	434	1931
	200	Standard	2.5 to 4	3000	13345	300	1334	3000	13345	300	1334
			5 to 8	3014	13407	182	810	3014	13407	182	810
		Heavy	2.5 to 4	6023	26752	771	3430	6014	26752	771	3430
			5 to 8	6524	29020	434	1931	6524	29020	434	1931
	300	Standard	2.5 to 4	5764	25640	448	1993	5764	25640	448	1993
			5 to 8	5854	26040	308	1370	5854	26040	308	1370
		Heavy	2.5 to 4	11490	51110	887	3946	11490	51110	887	3946
			5 to 8	11551	51381	519	2309	11551	51381	519	2309
	400	Standard	2.5 to 4	5764	25640	448	1993	5764	25640	448	1993
			5 to 8	5854	26040	308	1370	5854	26040	308	1370
		Heavy	2.5 to 4	11490	51110	887	3946	11490	51110	887	3946
			5 to 8	11551	51381	519	2309	11551	51381	519	2309
VL-UHC	25	Standard	0.75 to 1.50	326	1450	150	667	335	1490	150	667
		Dual	0.75	1021	3519	465	2068	--	--	--	--
			1.00 to 1.50	1021	3519	465	2068	--	--	--	--
	50	Standard	1.50 to 2.50	594	2642	166	738	668	2971	166	738
		Dual	1.50 to 2.50	1905	8474	506	2251	--	--	--	--
	100 & 200	Standard	2.00 to 4.00	1450	6450	289	1286	1636	7197	289	1286
Dual		2.00 to 4.00	4083	18162	805	3581	--	--	--	--	

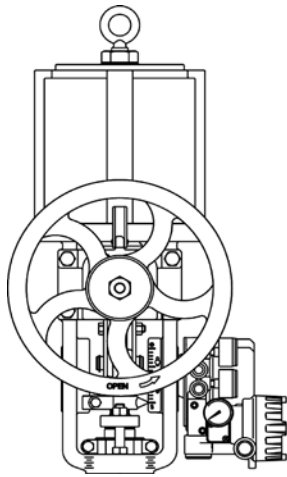

Side-Mounted Continuously Connected Handwheel

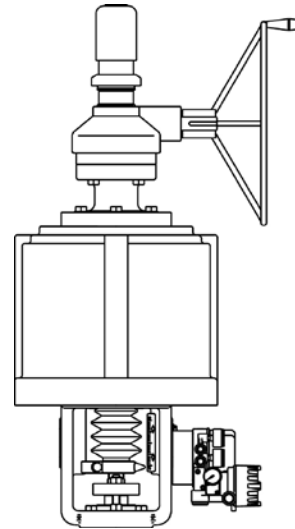
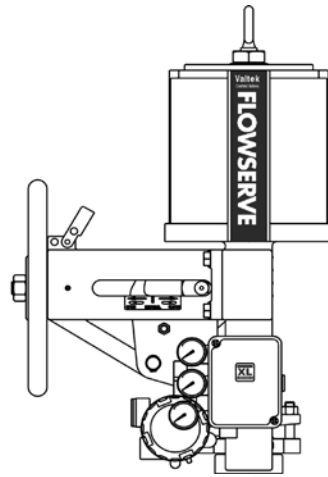

Top-Mounted Continuously Connected Handwheel

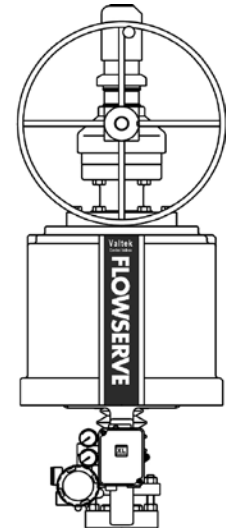

Manual Handwheel Override Specifications

	Actuator Style				Actuator Size	Spud	HW Operator Size	HW Diameter		HW Turns per		Force Amplification Factor	Maximum Stroke		Weight ⁽²⁾	
	VL	VL-C	VL-UHC	VL-ES				in.	mm	in.	mm		in.	mm	in.	mm
Side-Mounted Continuously Connected Handwheel	•	•	•		25	2.00	25	9	229	5.3	135	44:1	1.5	38	17	8
	•	•	•		50	2.00	25	12	305	5.3	135	58:1	1.5	38	24	11
	•	•	•		50	2.62	50	12	305	6.7	170	63:1	3.0	76	41	19
	•	•	•		100 ⁽¹⁾	2.62	50	18	457	6.7	170	95:1	4.0	102	48	22
	•	•	•	•	100	2.88-4.75	100/200	24	610	8	203	126:1	4.0	102	115	52
		•		•	150	2.88-4.75	100/200	24	610	8	203	126:1	4.0	102	115	52
	•		•		200	2.88-4.75	100/200	24	610	8	203	126:1	4.0	102	115	52
Top-Mounted Continuously Connected Handwheel	•	•	•	•	100	2.62-4.75	100/200	18	457	12	305	128:1	8.0	152/203	175	79
		•		•	150	2.62-4.75	100/200	18	457	12	305	128:1	8.0	152/203	175	79
	•	•	•	•	200	2.62-4.75	100/200	18	457	12	305	128:1	8.0	152/203	175	79
	•	•		•	300	2.62-4.75	100/200	18	457	12	305	128:1	8.0	152/203	175	79
	•	•		•	400	2.62-4.75	100/200	18	457	12	305	128:1	8.0	152/203	175	79
	•				500	2.62-4.75	100/200	18	457	12	305	128:1	8.0	152/203	175	79
	•				600	2.62-4.75	100/200	18	457	12	305	128:1	8.0	152/203	175	79

(1) 100 psi (6.89 Bar) maximum supply pressure when 50-inch HW Operator is used on a 100-inch actuator.

(2) Weights listed are for manual handwheel without actuator. Top mounted handwheel weights are for 4-inch stroke.

Allowable Cylinder Pressure for Balanced Valves

Valve Size	Pressure Class	Spud Size		VL																25	
				25		50		100		200		300		400		500		600		psi	bar
		in.	mm	psi	bar	psi	bar	psi	bar	psi	bar	psi	bar	psi	bar	psi	bar	psi	bar	psi	bar
1.5 to 2	150-600	2.00	51	150	10.3	90	6.2													150	10.3
	900-2500	2.00	51	150	10.3	90	6.2													150	10.3
3	900-2500	2.62	67			90	6.2														
	150-600	2.00	51	150	10.3	150	10.3													150	10.3
	900-1500	2.88	73					105	7.2	50	3.4										
4	2500	3.38	86					105	7.2	50	3.4										
	150-600	2.62	67			150	10.3	105	7.2	50	3.4										
	900-1500	3.38	86					150	10.3	95	6.6	60	4.1								
6	2500	3.38	86					150	10.3	95	6.6	60	4.1								
	150	2.62	67			150	10.3	150	10.3	95	6.6										
	300-600	3.38	86					150	10.3	150	10.3	115	7.9	90	6.2						
	900-1500	3.38	86					150	10.3	150	10.3	115	7.9	90	6.2						
8	2500	4.75	121					150	10.3	150	10.3	145	10.0	100	6.9	85	5.9	70	4.8		
	150-600	3.38	86					150	10.3	150	10.3	145	10.0	100	6.9	85	5.9	70	4.8		
	900-1500	3.38	86					150	10.3	150	10.3	150	10.3	100	6.9	100	6.9	100	6.9		
10	2500	4.75	121					150	10.3	150	10.3	150	10.3	100	6.9	100	6.9	100	6.9		
	150-600	3.38	86					150	10.3	150	10.3	150	10.3	100	6.9	100	6.9	100	6.9		
	900-2500	4.75	121					150	10.3	150	10.3	150	10.3	100	6.9	100	6.9	100	6.9		
12	150-2500	4.75	121					150	10.3	150	10.3	150	10.3	100	6.9	100	6.9	100	6.9		
	150	4.75	121					150	10.3	150	10.3	150	10.3	100	6.9	100	6.9	100	6.9		
14	150	4.75	121					150	10.3	150	10.3	150	10.3	100	6.9	100	6.9	100	6.9		
	300-2500	4.75	121					150	10.3	150	10.3	150	10.3	100	6.9	100	6.9	100	6.9		

Includes balanced; Mark One, Mark One-X, Mark Two, Mark Eight, Survivor, Mark 100, MegaStream, CavControl, ChannelStream, TigerTooth

Does not include metal bellows or bonnet extensions

Non-vertical mounting may require actuator support.

Maximum supply pressure is dependent on actuator mounting and connection strength.



Actuator Style and Size																							
VL-C								VL-UHC						VL-ES									
50		100		150		200		25		50		100		100		150		200		300		400	
psi	bar	psi	bar	psi	bar	psi	bar	psi	bar	psi	bar	psi	bar	psi	bar	psi	bar	psi	bar	psi	bar	psi	bar
90	6.2							150	10.3	90	6.2												
90	6.2							150	10.3	90	6.2												
90	6.2									90	6.2												
150	10.3							150	10.3	150	10.3												
		105	7.2	70	4.8	50	3.4					105	7.2	105	7.2	70	4.8	50	3.4				
		105	7.2	70	4.8	50	3.4					105	7.2	105	7.2	70	4.8	50	3.4				
150	10.3	105	7.2	70	4.8	50	3.4			150	10.3	105	7.2										
		150	10.3	120	8.3	95	6.6					150	10.3	150	10.3	120	8.3	95	6.6	60	4.1		
		150	10.3	120	8.3	95	6.6					150	10.3	150	10.3	120	8.3	95	6.6	60	4.1		
150	10.3	150	10.3	120	8.3	95	6.6			150	10.3	150	10.3										
		150	10.3	150	10.3	150	10.3					150	10.3	150	10.3	150	10.3	150	10.3	115	7.9		
		150	10.3	150	10.3	150	10.3					150	10.3	150	10.3	150	10.3	150	10.3	115	7.9		
		150	10.3	150	10.3	150	10.3					150	10.3	150	10.3	150	10.3	150	10.3	120	8.3	100	6.9
		150	10.3	150	10.3	150	10.3					150	10.3	150	10.3	150	10.3	150	10.3	120	8.3		
		150	10.3	150	10.3	150	10.3					150	10.3	150	10.3	150	10.3	150	10.3	150	10.3	100	6.9
		150	10.3	150	10.3	150	10.3					150	10.3	150	10.3	150	10.3	150	10.3	150	10.3	100	6.9
		150	10.3	150	10.3	150	10.3					150	10.3	150	10.3	150	10.3	150	10.3	150	10.3	100	6.9
		150	10.3	150	10.3	150	10.3					150	10.3	150	10.3	150	10.3	150	10.3	150	10.3	100	6.9
		150	10.3	150	10.3	150	10.3					150	10.3	150	10.3	150	10.3	150	10.3	150	10.3	100	6.9

Allowable Cylinder Pressure for Unbalanced Valves

Valve Size	Pressure Class	Spud Size		VL																25		50	
				25		50		100		200		300		400		500		600		psi	bar		
		in.	mm	psi	bar	psi	bar	psi	bar	psi	bar	psi	bar	psi	bar	psi	bar	psi	bar	psi	bar	psi	bar
.5 to 1	150-2500	2.00	51	150	10.3	90	6.2													150	10.3	90	
		2.00	51	150	10.3	150	10.3													150	10.3	150	
1.5 to 2	150-600	2.00	51	150	10.3	150	10.3													150	10.3	150	
	900-2500	2.62	67			150	10.3	105	7.2	50	3.4											150	
3	150-300	2.62	67			150	10.3	150	10.3	90	6.2											150	
	600	2.62	67			150	10.3	150	10.3	80	5.5											150	
	900	3.38	86					150	10.3	150	10.3	110	7.6	85	5.9								
	1500	3.38	86					150	10.3	150	10.3	100	6.9	80	5.5								
	2500	3.38	86					150	10.3	95	6.6												
4	150-600	2.62	67			150	10.3															150	
	150-600	2.88	73					150	10.3	95	6.6												
	900	3.38	86					150	10.3	150	10.3	110	7.6	85	5.9								
	1500	3.38	86					150	10.3	150	10.3	100	6.9	80	5.5								
	2500	4.00	102					150	10.3	140	9.7	90	6.2	70	4.8								
6	150	2.62	67			150	10.3															150	
	150	2.88	73					150	10.3	95	6.6												
	300-600	3.38	86					150	10.3	150	10.3	150	10.3	100	6.9								
	900-1500	4.00	102					150	10.3	150	10.3	150	10.3	100	6.9								
	2500	4.75	121					150	10.3	150	10.3	130	9.0	100	6.9								
8	150	3.38	86					150	10.3	150	10.3	110	7.6	85	5.9								
	300-600	3.38	86					150	10.3	150	10.3	150	10.3	100	6.9								
	900-2500	4.75	121					150	10.3	150	10.3	150	10.3	100	6.9	100	6.9	100	6.9				
10	150	3.38	86					150	10.3	150	10.3	150	10.3	100	6.9								
	300-600	4.75	121					150	10.3	150	10.3	150	10.3	100	6.9	100	6.9	100	6.9				
	900-2500	4.75	121					150	10.3	150	10.3	150	10.3	100	6.9	100	6.9	100	6.9				
12	150	3.38	86					150	10.3	150	10.3	150	10.3	100	6.9								
	300-2500	4.75	121					150	10.3	150	10.3	150	10.3	100	6.9	100	6.9	100	6.9				
14	150-2500	4.75	121					150	10.3	150	10.3	150	10.3	100	6.9	100	6.9	100	6.9				

Includes unbalanced; Mark One, Mark One-X, Mark Two, Mark Eight, Survivor, MegaStream, CavControl, ChannelStream, TigerTooth

Does not include metal bellows or bonnet extensions

Maximum supply pressure is dependant on actuator mounting and connection strength

Non-vertical mounting may require actuator support.



Actuator Style and Size																								
VL-C							VL-UHC						VL-ES											
50		100		150		200		25		50		100		100		150		200		300		400		
bar	psi	bar	psi	bar	psi	bar	psi	bar	psi	bar	psi	bar	psi	bar	psi	bar	psi	bar	psi	bar	psi	bar		
6.2							150	10.3	90	6.2														
10.3							150	10.3	150	10.3														
10.3	105	7.2	70	4.8	50	3.4			150	10.3	105	7.2												
10.3	150	10.3	120	8.3	90	6.2			150	10.3	150	10.3												
10.3	150	10.3	105	7.2	80	5.5			150	10.3	150	10.3												
	150	10.3	150	10.3	150	10.3					150	10.3	150	10.3	150	10.3	150	10.3	150	10.3	110	7.6		
	150	10.3	150	10.3	150	10.3					150	10.3	150	10.3	150	10.3	150	10.3	150	10.3	100	6.9		
	150	10.3	120	8.3	95	6.6					150	10.3	150	10.3	120	8.3	95	6.6						
10.3									150	10.3														
	150	10.3	120	8.3	95	6.6					150	10.3	150	10.3	120	8.3	95	6.6						
	150	10.3	150	10.3	150	10.3					150	10.3	150	10.3	150	10.3	150	10.3	150	10.3	110	7.6		
	150	10.3	150	10.3	150	10.3					150	10.3	150	10.3	150	10.3	150	10.3	150	10.3	100	6.9		
	150	10.3	150	10.3	140	9.7					150	10.3	150	10.3	150	10.3	140	9.7	90	6.2				
10.3									150	10.3														
	150	10.3	120	8.3	95	6.6					150	10.3	150	10.3	120	8.3	95	6.6						
	150	10.3	150	10.3	150	10.3					150	10.3	150	10.3	150	10.3	150	10.3	150	10.3	120	8.3		
	150	10.3	150	10.3	150	10.3					150	10.3	150	10.3	150	10.3	150	10.3	150	10.3	120	8.3		
	150	10.3	150	10.3	150	10.3					150	10.3	150	10.3	150	10.3	150	10.3	150	10.3	130	9.0	100	6.9
	150	10.3	150	10.3	150	10.3					150	10.3	150	10.3	150	10.3	150	10.3	150	10.3	110	7.6		
	150	10.3	150	10.3	150	10.3					150	10.3	150	10.3	150	10.3	150	10.3	150	10.3	120	8.3		
	150	10.3	150	10.3	150	10.3					150	10.3	150	10.3	150	10.3	150	10.3	150	10.3	150	10.3	100	6.9
	150	10.3	150	10.3	150	10.3					150	10.3	150	10.3	150	10.3	150	10.3	150	10.3	150	10.3	100	6.9
	150	10.3	150	10.3	150	10.3					150	10.3	150	10.3	150	10.3	150	10.3	150	10.3	150	10.3	100	6.9
	150	10.3	150	10.3	150	10.3					150	10.3	150	10.3	150	10.3	150	10.3	150	10.3	120	8.3		
	150	10.3	150	10.3	150	10.3					150	10.3	150	10.3	150	10.3	150	10.3	150	10.3	150	10.3	100	6.9
	150	10.3	150	10.3	150	10.3					150	10.3	150	10.3	150	10.3	150	10.3	150	10.3	150	10.3	100	6.9



Mounting Dimensions, VL, VL-UHC

Actuator Size	Spud Size		Max Stroke Length		Stem Thread	Bolt Circle		Mounting Bolts		Spud Thickness		Stem Extended	Stem Extended	Stem Thread Depth
	A		in.	mm	E	B		Size	Qty	C		D	D	F
	in.	mm			in.	mm	in.			mm	in.	mm	in.	mm
25	2.00	50.80	1.50	38.10	½-20	N/R	N/R	N/R	N/R	0.69	17.60	2.94	74.68	1.00
	2.00	50.80	1.50	38.10	¾-16	N/R	N/R	N/R	N/R	0.69	17.60	2.94	74.68	1.00
50	2.00	50.80	1.50	38.10	½-20	N/R	N/R	N/R	N/R	0.69	17.60	2.94	74.68	1.00
	2.00	50.80	1.50	38.10	¾-16	N/R	N/R	N/R	N/R	0.69	17.60	2.94	74.68	1.00
	2.62	66.55	3.00	76.20	½-20	N/R	N/R	N/R	N/R	1.06	26.97	3.56	90.42	1.00
	2.62	66.55	3.00	76.20	¾-16	N/R	N/R	N/R	N/R	1.06	26.97	3.56	90.42	1.00
100	2.62	66.55	3.00	76.20	½-20	N/R	N/R	N/R	N/R	1.06	26.97	3.56	90.42	1.00
	2.62	66.55	3.00	76.20	¾-16	N/R	N/R	N/R	N/R	1.06	26.97	3.56	90.42	1.00
	2.62	66.55	3.00	76.20	1-12	N/R	N/R	N/R	N/R	1.06	26.97	3.56	90.42	1.38
	2.88	73.15	4.00	101.60	½-20	N/R	N/R	N/R	N/R	1.13	28.58	4.28	108.71	1.00
	2.88	73.15	4.00	101.60	¾-16	N/R	N/R	N/R	N/R	1.13	28.58	4.28	108.71	1.00
	2.88	73.15	4.00	101.60	1-12	N/R	N/R	N/R	N/R	1.13	28.58	4.28	108.71	1.38
	3.38	85.85	4.00	101.60	1-12	5.00	127.00	.625-11	6.00	1.50	38.10	4.88	123.95	1.38
	3.38	85.85	4.00	101.60	1½-12	5.00	127.00	.625-11	6.00	1.50	38.10	4.88	123.95	1.75
	3.38	85.85	4.00	101.60	1½-12	5.00	127.00	.625-11	6.00	1.50	38.10	4.88	123.95	2.00
	3.38	85.85	8.00	203.20	1-12	5.00	127.00	.625-11	6.00	1.50	38.10	4.88	123.95	1.38
	3.38	85.85	8.00	203.20	1½-12	5.00	127.00	.625-11	6.00	1.50	38.10	4.88	123.95	1.75
	3.38	85.85	8.00	203.20	1½-12	5.00	127.00	.625-11	6.00	1.50	38.10	4.88	123.95	2.00
	4.00	101.60	4.00	101.60	1-12	5.75	146.05	.625-11	6.00	1.50	38.10	4.88	123.95	1.38
	4.00	101.60	4.00	101.60	1½-12	5.75	146.05	.625-11	6.00	1.50	38.10	4.88	123.95	1.75
	4.00	101.60	4.00	101.60	1½-12	5.75	146.05	.625-11	6.00	1.50	38.10	4.88	123.95	2.00
	4.75	120.65	4.00	101.60	1-12	6.50	165.10	.625-11	6.00	1.50	38.10	4.88	123.95	1.38
4.75	120.65	4.00	101.60	1½-12	6.50	165.10	.625-11	6.00	1.50	38.10	4.88	123.95	1.75	
4.75	120.65	4.00	101.60	1½-12	6.50	165.10	.625-11	6.00	1.50	38.10	4.88	123.95	2.00	
4.75	120.65	8.00	203.20	1-12	6.50	165.10	.625-11	6.00	1.50	38.10	4.88	123.95	1.38	
4.75	120.65	8.00	203.20	1½-12	6.50	165.10	.625-11	6.00	1.50	38.10	4.88	123.95	1.75	
4.75	120.65	8.00	203.20	1½-12	6.50	165.10	.625-11	6.00	1.50	38.10	4.88	123.95	2.00	
200	2.88	73.15	4.00	101.60	½-20	N/R	N/R	N/R	N/R	1.13	28.58	4.28	108.71	1.00
	2.88	73.15	4.00	101.60	¾-16	N/R	N/R	N/R	N/R	1.13	28.58	4.28	108.71	1.00
	2.88	73.15	4.00	101.60	1-12	N/R	N/R	N/R	N/R	1.13	28.58	4.28	108.71	1.38
	3.38	85.85	4.00	101.60	1-12	5.00	127.00	.625-11	6.00	1.50	38.10	4.88	123.95	1.38
	3.38	85.85	4.00	101.60	1½-12	5.00	127.00	.625-11	6.00	1.50	38.10	4.88	123.95	1.75
	3.38	85.85	4.00	101.60	1½-12	5.00	127.00	.625-11	6.00	1.50	38.10	4.88	123.95	2.00
	3.38	85.85	8.00	203.20	1-12	5.00	127.00	.625-11	6.00	1.50	38.10	4.88	123.95	1.38
	3.38	85.85	8.00	203.20	1½-12	5.00	127.00	.625-11	6.00	1.50	38.10	4.88	123.95	1.75
	3.38	85.85	8.00	203.20	1½-12	5.00	127.00	.625-11	6.00	1.50	38.10	4.88	123.95	2.00
4.00	101.60	4.00	101.60	1-12	5.75	146.05	.625-11	6.00	1.50	38.10	4.88	123.95	1.38	

(1) Dimension may change when using a side mounted handwheel. Contact the Factory for details when using side mounted handwheels.

Stem Thread Depth	Stem Diameter		Mounting Pad Offset		Mounting Pad Hole Height ⁽¹⁾		Mounting Pad Hole Spacing		Mounting Pad Spacing		Mounting Pad Bolt Size
	F	G		H		I		J		K	
mm	in.	mm	in.	mm	in.	mm	in.	mm	in.	mm	L
25.40	0.995	25.27	2.44	61.98	3.35	85.09	1.31	33.27	0.31	7.94	3/16-18
25.40	0.995	25.27	2.44	61.98	3.35	85.09	1.31	33.27	0.31	7.94	3/16-18
25.40	1.370	34.80	3.19	81.03	3.38	85.85	1.31	33.27	0.31	7.94	3/16-18
25.40	1.370	34.80	3.19	81.03	3.38	85.85	1.31	33.27	0.31	7.94	3/16-18
25.40	1.370	34.80	3.19	81.03	4.78	121.41	1.31	33.27	0.31	7.94	3/16-18
25.40	1.370	34.80	3.19	81.03	4.78	121.41	1.31	33.27	0.31	7.94	3/16-18
35.05	1.370	34.80	3.19	81.03	4.78	121.41	1.31	33.27	0.31	7.94	3/16-18
25.40	1.496	38.00	4.56	115.82	6.13	155.70	1.31	33.27	0.50	12.70	3/16-18
25.40	1.496	38.00	4.56	115.82	6.13	155.70	1.31	33.27	0.50	12.70	3/16-18
35.05	1.496	38.00	4.56	115.82	6.13	155.70	1.31	33.27	0.50	12.70	3/16-18
25.40	1.496	38.00	4.56	115.82	6.13	155.70	1.31	33.27	0.50	12.70	3/16-18
25.40	1.496	38.00	4.56	115.82	6.13	155.70	1.31	33.27	0.50	12.70	3/16-18
35.05	1.496	38.00	4.56	115.82	6.13	155.70	1.31	33.27	0.50	12.70	3/16-18
35.05	2.245	57.02	4.88	123.83	6.25	158.75	2.50	63.50	0.50	12.70	3/8-16
44.45	2.245	57.02	4.88	123.83	6.25	158.75	2.50	63.50	0.50	12.70	3/8-16
50.80	2.245	57.02	4.88	123.83	6.25	158.75	2.50	63.50	0.50	12.70	3/8-16
35.05	2.245	57.02	5.13	130.18	8.19	208.03	2.50	63.50	0.75	19.05	3/8-16
44.45	2.245	57.02	5.13	130.18	8.19	208.03	2.50	63.50	0.75	19.05	3/8-16
50.80	2.245	57.02	5.13	130.18	8.19	208.03	2.50	63.50	0.75	19.05	3/8-16
35.05	2.245	57.02	5.31	134.87	6.25	158.75	2.50	63.50	0.50	12.70	3/8-16
44.45	2.245	57.02	5.31	134.87	6.25	158.75	2.50	63.50	0.50	12.70	3/8-16
50.80	2.245	57.02	5.31	134.87	6.25	158.75	2.50	63.50	0.50	12.70	3/8-16
35.05	2.245	57.02	5.31	134.87	6.25	158.75	2.50	63.50	0.50	12.70	3/8-16
44.45	2.245	57.02	5.31	134.87	6.25	158.75	2.50	63.50	0.50	12.70	3/8-16
50.80	2.245	57.02	5.31	134.87	6.25	158.75	2.50	63.50	0.50	12.70	3/8-16
35.05	2.245	57.02	5.13	130.18	8.19	208.03	2.50	63.50	0.75	19.05	3/8-16
44.45	2.245	57.02	5.13	130.18	8.19	208.03	2.50	63.50	0.75	19.05	3/8-16
50.80	2.245	57.02	5.13	130.18	8.19	208.03	2.50	63.50	0.75	19.05	3/8-16
25.40	1.496	38.00	4.56	115.82	6.13	155.70	1.31	33.27	0.50	12.70	3/16-18
25.40	1.496	38.00	4.56	115.82	6.13	155.70	1.31	33.27	0.50	12.70	3/16-18
35.05	1.496	38.00	4.56	115.82	6.13	155.70	1.31	33.27	0.50	12.70	3/16-18
35.05	2.245	57.02	4.88	123.83	6.25	158.75	2.50	63.50	0.50	12.70	3/8-16
44.45	2.245	57.02	4.88	123.83	6.25	158.75	2.50	63.50	0.50	12.70	3/8-16
50.80	2.245	57.02	4.88	123.83	6.25	158.75	2.50	63.50	0.50	12.70	3/8-16
35.05	2.245	57.02	5.13	130.18	8.19	208.03	2.50	63.50	0.75	19.05	3/8-16
44.45	2.245	57.02	5.13	130.18	8.19	208.03	2.50	63.50	0.75	19.05	3/8-16
50.80	2.245	57.02	5.13	130.18	8.19	208.03	2.50	63.50	0.75	19.05	3/8-16
35.05	2.245	57.02	5.31	134.87	6.25	158.75	2.50	63.50	0.50	12.70	3/8-16
44.45	2.245	57.02	5.31	134.87	6.25	158.75	2.50	63.50	0.50	12.70	3/8-16
50.80	2.245	57.02	5.31	134.87	6.25	158.75	2.50	63.50	0.50	12.70	3/8-16

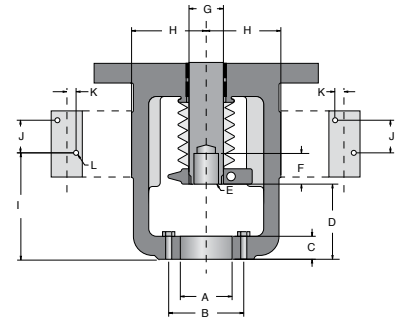



Mounting Dimensions, VL, VL-UHC (Continued)

Actuator Size	Spud Size		Max Stroke Length		Stem Thread	Bolt Circle		Mounting Bolts		Spud Thickness		Stem Extended	Stem Extended	Stem Thread Depth
	A		in.	mm	E	B		Size	Qty	C		D	D	F
	in.	mm				in.	mm			in.	mm			
200	4.00	101.60	4.00	101.60	1½-12	5.75	146.05	.625-11	6.00	1.50	38.10	4.88	123.95	1.75
	4.00	101.60	4.00	101.60	1½-12	5.75	146.05	.625-11	6.00	1.50	38.10	4.88	123.95	2.00
	4.75	120.65	4.00	101.60	1-12	6.50	165.10	.625-11	6.00	1.50	38.10	4.88	123.95	1.38
	4.75	120.65	4.00	101.60	1½-12	6.50	165.10	.625-11	6.00	1.50	38.10	4.88	123.95	1.75
	4.75	120.65	4.00	101.60	1½-12	6.50	165.10	.625-11	6.00	1.50	38.10	4.88	123.95	2.00
	4.75	120.65	8.00	203.20	1-12	6.50	165.10	.625-11	6.00	1.50	38.10	4.88	123.95	1.38
	4.75	120.65	8.00	203.20	1½-12	6.50	165.10	.625-11	6.00	1.50	38.10	4.88	123.95	1.75
	4.75	120.65	8.00	203.20	1½-12	6.50	165.10	.625-11	6.00	1.50	38.10	4.88	123.95	2.00
300	3.38	85.85	4.00	101.60	1½-12	4.88	123.95	.750-10	6.00	1.50	38.10	4.88	123.95	2.00
	3.38	85.85	4.00	101.60	2-12	4.88	123.95	.750-10	6.00	1.50	38.10	4.88	123.95	2.62
	3.38	85.85	8.00	203.20	1½-12	4.88	123.95	.750-10	6.00	1.50	38.10	4.88	123.95	2.00
	3.38	85.85	8.00	203.20	2-12	4.88	123.95	.750-10	6.00	1.50	38.10	4.88	123.95	2.62
	3.38	85.85	12.00	304.80	1½-12	4.88	123.95	.750-10	6.00	1.50	38.10	4.88	123.95	2.00
	3.38	85.85	12.00	304.80	2-12	4.88	123.95	.750-10	6.00	1.50	38.10	4.88	123.95	2.62
	4.00	101.60	4.00	101.60	1½-12	6.50	165.10	.750-10	8.00	1.50	38.10	4.88	123.95	2.00
	4.00	101.60	4.00	101.60	2-12	6.50	165.10	.750-10	8.00	1.50	38.10	4.88	123.95	2.62
	4.75	120.65	4.00	101.60	1½-12	6.50	165.10	.750-10	8.00	1.50	38.10	4.88	123.95	2.00
	4.75	120.65	4.00	101.60	2-12	6.50	165.10	.750-10	8.00	1.50	38.10	4.88	123.95	2.62
	4.75	120.65	8.00	203.20	1½-12	6.50	165.10	.750-10	8.00	1.50	38.10	4.88	123.95	2.00
	4.75	120.65	8.00	203.20	2-12	6.50	165.10	.750-10	8.00	1.50	38.10	4.88	123.95	2.62
400	3.38	85.85	4.00	101.60	1½-12	4.88	123.95	.750-10	6.00	1.50	38.10	4.88	123.95	2.00
	3.38	85.85	4.00	101.60	2-12	4.88	123.95	.750-10	6.00	1.50	38.10	4.88	123.95	2.62
	3.38	85.85	8.00	203.20	1½-12	4.88	123.95	.750-10	6.00	1.50	38.10	4.88	123.95	2.00
	3.38	85.85	8.00	203.20	2-12	4.88	123.95	.750-10	6.00	1.50	38.10	4.88	123.95	2.62
	4.75	120.65	4.00	101.60	1½-12	6.50	165.10	.750-10	8.00	1.50	38.10	4.88	123.95	2.00
	4.75	120.65	4.00	101.60	2-12	6.50	165.10	.750-10	8.00	1.50	38.10	4.88	123.95	2.62
	4.75	120.65	8.00	203.20	1½-12	6.50	165.10	.750-10	8.00	1.50	38.10	4.88	123.95	2.00
	4.75	120.65	8.00	203.20	2-12	6.50	165.10	.750-10	8.00	1.50	38.10	4.88	123.95	2.62
500	3.38	85.85	8.00	203.20	1½-12	4.88	123.95	.750-10	6.00	1.50	38.10	4.88	123.95	2.00
	3.38	85.85	8.00	203.20	2-12	4.88	123.95	.750-10	6.00	1.50	38.10	4.88	123.95	2.62
	4.75	120.65	8.00	203.20	1½-12	6.50	165.10	.750-10	8.00	1.50	38.10	4.88	123.95	2.00
	4.75	120.65	8.00	203.20	2-12	6.50	165.10	.750-10	8.00	1.50	38.10	4.88	123.95	2.62
600	4.75	120.65	4.00	101.60	1½-12	6.50	165.10	.750-10	8.00	1.50	38.10	4.88	123.95	2.00
	4.75	120.65	4.00	101.60	2-12	6.50	165.10	.750-10	8.00	1.50	38.10	4.88	123.95	2.62
	4.75	120.65	8.00	203.20	1½-12	6.50	165.10	.750-10	8.00	1.50	38.10	4.88	123.95	2.00
	4.75	120.65	8.00	203.20	2-12	6.50	165.10	.750-10	8.00	1.50	38.10	4.88	123.95	2.62

(1) Dimension may change when using a side mounted handwheel. Contact the Factory for details when using side mounted handwheels.

	Stem Thread Depth		Stem Diameter		Mounting Pad Offset		Mounting Pad Hole Height ⁽¹⁾		Mounting Pad Hole Spacing		Mounting Pad Hole Spacing		Mounting Pad Bolt Size
	F		G		H		I		J		K		
	mm	in.	mm	in.	mm	in.	mm	in.	mm	in.	mm	in.	
	44.45	2.245	57.02	5.31	134.87	6.25	158.75	2.50	63.50	0.50	12.70	3/8-16	
	50.80	2.245	57.02	5.31	134.87	6.25	158.75	2.50	63.50	0.50	12.70	3/8-16	
	35.05	2.245	57.02	5.31	134.87	6.25	158.75	2.50	63.50	0.50	12.70	3/8-16	
	44.45	2.245	57.02	5.31	134.87	6.25	158.75	2.50	63.50	0.50	12.70	3/8-16	
	50.80	2.245	57.02	5.31	134.87	6.25	158.75	2.50	63.50	0.50	12.70	3/8-16	
	35.05	2.245	57.02	5.13	130.18	8.19	208.03	2.50	63.50	0.75	19.05	3/8-16	
	44.45	2.245	57.02	5.13	130.18	8.19	208.03	2.50	63.50	0.75	19.05	3/8-16	
	50.80	2.245	57.02	5.13	130.18	8.19	208.03	2.50	63.50	0.75	19.05	3/8-16	
	50.80	2.745	69.72	5.75	146.05	6.19	157.23	2.50	63.50	0.75	19.05	3/8-16	
	66.55	2.745	69.72	5.75	146.05	6.19	157.23	2.50	63.50	0.75	19.05	3/8-16	
	50.80	2.745	69.72	5.75	146.05	8.19	208.03	2.50	63.50	0.75	19.05	3/8-16	
	66.55	2.745	69.72	5.75	146.05	8.19	208.03	2.50	63.50	0.75	19.05	3/8-16	
	50.80	2.745	69.72	5.75	146.05	8.19	208.03	2.50	63.50	0.75	19.05	3/8-16	
	66.55	2.745	69.72	5.75	146.05	8.19	208.03	2.50	63.50	0.75	19.05	3/8-16	
	50.80	2.745	69.72	5.75	146.05	8.19	208.03	2.50	63.50	0.75	19.05	3/8-16	
	66.55	2.745	69.72	5.75	146.05	8.19	208.03	2.50	63.50	0.75	19.05	3/8-16	
	50.80	2.745	69.72	5.75	146.05	8.19	208.03	2.50	63.50	0.75	19.05	3/8-16	
	66.55	2.745	69.72	5.75	146.05	8.19	208.03	2.50	63.50	0.75	19.05	3/8-16	
	50.80	2.745	69.72	5.75	146.05	8.19	208.03	2.50	63.50	0.75	19.05	3/8-16	
	66.55	2.745	69.72	5.75	146.05	8.19	208.03	2.50	63.50	0.75	19.05	3/8-16	
	50.80	2.745	69.72	5.75	146.05	8.19	208.03	2.50	63.50	0.75	19.05	3/8-16	
	66.55	2.745	69.72	5.75	146.05	8.19	208.03	2.50	63.50	0.75	19.05	3/8-16	
	50.80	2.745	69.72	5.75	146.05	8.19	208.03	2.50	63.50	0.75	19.05	3/8-16	
	66.55	2.745	69.72	5.75	146.05	8.19	208.03	2.50	63.50	0.75	19.05	3/8-16	
	50.80	2.745	69.72	4.88	123.83	6.25	158.75	2.50	63.50	0.50	12.70	3/8-16	
	66.55	2.745	69.72	4.88	123.83	6.25	158.75	2.50	63.50	0.50	12.70	3/8-16	
	50.80	2.745	69.72	4.88	123.83	8.19	208.03	2.50	63.50	0.75	19.05	3/8-16	
	66.55	2.745	69.72	5.13	130.18	8.19	208.03	2.50	63.50	0.75	19.05	3/8-16	
	50.80	2.745	69.72	5.31	134.87	6.25	158.75	2.50	63.50	0.75	19.05	3/8-16	
	66.55	2.745	69.72	5.31	134.87	6.25	158.75	2.50	63.50	0.75	19.05	3/8-16	
	50.80	2.745	69.72	5.13	130.18	8.19	208.03	2.50	63.50	0.75	19.05	3/8-16	
	66.55	2.745	69.72	5.13	130.18	8.19	208.03	2.50	63.50	0.75	19.05	3/8-16	
	50.80	2.745	69.72	5.75	146.05	8.19	208.03	2.50	63.50	0.75	19.05	3/8-16	
	66.55	2.745	69.72	5.75	146.05	8.19	208.03	2.50	63.50	0.75	19.05	3/8-16	
	50.80	2.745	69.72	5.75	146.05	8.19	208.03	2.50	63.50	0.75	19.05	3/8-16	
	66.55	2.745	69.72	5.75	146.05	8.19	208.03	2.50	63.50	0.75	19.05	3/8-16	
	50.80	2.745	69.72	5.75	146.05	8.19	208.03	2.50	63.50	0.75	19.05	3/8-16	
	66.55	2.745	69.72	5.75	146.05	8.19	208.03	2.50	63.50	0.75	19.05	3/8-16	
	50.80	2.745	69.72	5.75	146.05	8.19	208.03	2.50	63.50	0.75	19.05	3/8-16	
	66.55	2.745	69.72	5.75	146.05	8.19	208.03	2.50	63.50	0.75	19.05	3/8-16	
	50.80	2.745	69.72	5.75	146.05	8.19	208.03	2.50	63.50	0.75	19.05	3/8-16	
	66.55	2.745	69.72	5.75	146.05	8.19	208.03	2.50	63.50	0.75	19.05	3/8-16	
	50.80	2.745	69.72	5.75	146.05	8.19	208.03	2.50	63.50	0.75	19.05	3/8-16	
	66.55	2.745	69.72	5.75	146.05	8.19	208.03	2.50	63.50	0.75	19.05	3/8-16	

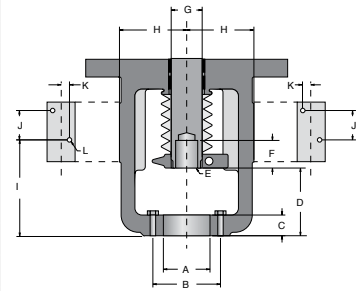

Mounting Dimensions, VL-C, VL-ES

Actuator Size	Spud Size		Max Stroke Length		Stem Thread	Bolt Circle		Mounting Bolts		Spud Thickness		Stem Extended		Stem Thread Depth
	A		E			B		Size	Qty	C		D		
	in.	mm	in.	mm	in.	mm	in.	mm	in.	mm	in.	mm	in.	
25	2.00	50.80	1.50	38.10	½-20	N/R	N/R	N/R	N/R	0.69	17.60	2.94	74.68	1.00
	2.00	50.80	1.50	38.10	¾-16	N/R	N/R	N/R	N/R	0.69	17.60	2.94	74.68	1.00
50	2.00	50.80	1.50	38.10	½-20	N/R	N/R	N/R	N/R	0.69	17.60	2.94	74.68	1.00
	2.00	50.80	1.50	38.10	¾-16	N/R	N/R	N/R	N/R	0.69	17.60	2.94	74.68	1.00
	2.62	66.55	3.00	76.20	½-20	N/R	N/R	N/R	N/R	1.06	26.97	3.56	90.42	1.00
	2.62	66.55	3.00	76.20	¾-16	N/R	N/R	N/R	N/R	1.06	26.97	3.56	90.42	1.00
	2.62	66.55	3.00	76.20	1-12	N/R	N/R	N/R	N/R	1.06	26.97	3.56	90.42	1.38
100	2.62	66.55	3.00	76.20	¾-16	N/R	N/R	N/R	N/R	1.06	26.97	3.56	90.42	1.00
	2.62	66.55	3.00	76.20	1-12	N/R	N/R	N/R	N/R	1.06	26.97	3.56	90.42	1.38
	2.88	73.15	4.00	101.60	½-20	N/R	N/R	N/R	N/R	1.13	28.58	4.28	108.71	1.00
	2.88	73.15	4.00	101.60	¾-16	N/R	N/R	N/R	N/R	1.13	28.58	4.28	108.71	1.00
	2.88	73.15	4.00	101.60	1-12	N/R	N/R	N/R	N/R	1.13	28.58	4.28	108.71	1.38
	3.38	85.85	4.00	101.60	1-12	5.00	127.00	.625-11	6	1.50	38.10	4.88	123.95	1.38
	3.38	85.85	4.00	101.60	1½-12	5.00	127.00	.625-11	6	1.50	38.10	4.88	123.95	1.75
	3.38	85.85	4.00	101.60	1½-12	5.00	127.00	.625-11	6	1.50	38.10	4.88	123.95	2.00
	3.38	85.85	8.00	203.20	1-12	5.00	127.00	.625-11	6	1.50	38.10	4.88	123.95	1.38
	3.38	85.85	8.00	203.20	1½-12	5.00	127.00	.625-11	6	1.50	38.10	4.88	123.95	1.75
	3.38	85.85	8.00	203.20	1½-12	5.00	127.00	.625-11	6	1.50	38.10	4.88	123.95	2.00
	4.00	101.60	4.00	101.60	1-12	5.75	146.05	.625-11	6	1.50	38.10	4.88	123.95	1.38
	4.00	101.60	4.00	101.60	1½-12	5.75	146.05	.625-11	6	1.50	38.10	4.88	123.95	1.75
	4.00	101.60	4.00	101.60	1½-12	5.75	146.05	.625-11	6	1.50	38.10	4.88	123.95	2.00
	4.75	120.65	4.00	101.60	1-12	6.50	165.10	.625-11	6	1.50	38.10	4.88	123.95	1.38
	4.75	120.65	4.00	101.60	1½-12	6.50	165.10	.625-11	6	1.50	38.10	4.88	123.95	1.75
	4.75	120.65	4.00	101.60	1½-12	6.50	165.10	.625-11	6	1.50	38.10	4.88	123.95	2.00
	150	4.75	120.65	8.00	203.20	1-12	6.50	165.10	.625-11	6	1.50	38.10	4.88	123.95
4.75		120.65	8.00	203.20	1½-12	6.50	165.10	.625-11	6	1.50	38.10	4.88	123.95	1.75
4.75		120.65	8.00	203.20	1½-12	6.50	165.10	.625-11	6	1.50	38.10	4.88	123.95	2.00
2.88		73.15	4.00	101.60	¾-16	N/R	N/R	N/R	N/R	1.13	28.58	4.28	108.71	1.00
2.88		73.15	4.00	101.60	1-12	N/R	N/R	N/R	N/R	1.13	28.58	4.28	108.71	1.38
3.38		85.85	4.00	101.60	¾-16	5.00	127.00	.625-11	6	1.50	38.10	4.88	123.95	1.00
3.38		85.85	4.00	101.60	1-12	5.00	127.00	.625-11	6	1.50	38.10	4.88	123.95	1.38
3.38		85.85	4.00	101.60	1½-12	5.00	127.00	.625-11	6	1.50	38.10	4.88	123.95	1.75
3.38		85.85	4.00	101.60	1½-12	5.00	127.00	.625-11	6	1.50	38.10	4.88	123.95	2.00
3.38		85.85	4.00	101.60	2-12	5.00	127.00	.625-11	6	1.50	38.10	4.88	123.95	2.62
3.38		85.85	8.00	203.20	1½-12	5.00	127.00	.625-11	6	1.50	38.10	4.88	123.95	1.75
3.38		85.85	8.00	203.20	1½-12	5.00	127.00	.625-11	6	1.50	38.10	4.88	123.95	2.00
3.38		85.85	8.00	203.20	2-12	5.00	127.00	.625-11	6	1.50	38.10	4.88	123.95	2.62
4.00		101.60	4.00	101.60	1½-12	5.75	146.05	.625-11	6	1.50	38.10	4.88	123.95	1.75
4.00		101.60	4.00	101.60	1½-12	5.75	146.05	.625-11	6	1.50	38.10	4.88	123.95	2.00
4.00		101.60	4.00	101.60	2-12	5.75	146.05	.625-11	6	1.50	38.10	4.88	123.95	2.62
4.00		101.60	8.00	203.20	1½-12	5.75	146.05	.625-11	6	1.50	38.10	4.88	123.95	1.75
4.00		101.60	8.00	203.20	1½-12	5.75	146.05	.625-11	6	1.50	38.10	4.88	123.95	2.00
4.00	101.60	8.00	203.20	2-12	5.75	146.05	.625-11	6	1.50	38.10	4.88	123.95	2.62	
4.75	120.65	4.00	101.60	1½-12	6.50	165.10	.625-11	6	1.50	38.10	4.88	123.95	1.75	
4.75	120.65	4.00	101.60	1½-12	6.50	165.10	.625-11	6	1.50	38.10	4.88	123.95	2.00	
4.75	120.65	4.00	101.60	2-12	6.50	165.10	.625-11	6	1.50	38.10	4.88	123.95	2.62	

(1) Dimension may change when using a side mounted handwheel. Contact the Factory for details when using side mounted handwheels.

Stem Thread Depth	Stem Diameter		Mounting Pad Offset		Mounting Pad Hole Height ⁽¹⁾		Mounting Pad Hole Spacing		Mounting Pad Hole Spacing		Mounting Pad Bolt Size
	F	G	H		J		K		L		
mm	in.	mm	in.	mm	in.	mm	in.	mm	in.	mm	
25.40	0.995	25.27	2.44	61.98	3.35	85.09	1.31	33.27	0.31	7.94	1 $\frac{1}{8}$ -18
25.40	0.995	25.27	2.44	61.98	3.35	85.09	1.31	33.27	0.31	7.94	1 $\frac{1}{8}$ -18
25.40	1.370	34.80	3.19	81.03	3.38	85.85	1.31	33.27	0.31	7.94	1 $\frac{1}{8}$ -18
25.40	1.370	34.80	3.19	81.03	3.38	85.85	1.31	33.27	0.31	7.94	1 $\frac{1}{8}$ -18
25.40	1.370	34.80	3.19	81.03	4.78	121.41	1.31	33.27	0.31	7.94	1 $\frac{1}{8}$ -18
25.40	1.370	34.80	3.19	81.03	4.78	121.41	1.31	33.27	0.31	7.94	1 $\frac{1}{8}$ -18
35.05	1.370	34.80	3.19	81.03	4.78	121.41	1.31	33.27	0.31	7.94	1 $\frac{1}{8}$ -18
25.40	1.496	38.00	4.56	115.82	6.13	155.70	1.31	33.27	0.50	12.70	1 $\frac{1}{8}$ -18
35.05	1.496	38.00	4.56	115.82	6.13	155.70	1.31	33.27	0.50	12.70	1 $\frac{1}{8}$ -18
25.40	1.496	38.00	4.56	115.82	6.13	155.70	1.31	33.27	0.50	12.70	1 $\frac{1}{8}$ -18
25.40	1.496	38.00	4.56	115.82	6.13	155.70	1.31	33.27	0.50	12.70	1 $\frac{1}{8}$ -18
35.05	1.496	38.00	4.56	115.82	6.13	155.70	1.31	33.27	0.50	12.70	1 $\frac{1}{8}$ -18
35.05	2.245	57.02	4.88	123.83	6.25	158.75	2.50	63.50	0.50	12.70	$\frac{3}{8}$ -16
44.45	2.245	57.02	4.88	123.83	6.25	158.75	2.50	63.50	0.50	12.70	$\frac{3}{8}$ -16
50.80	2.245	57.02	4.88	123.83	6.25	158.75	2.50	63.50	0.50	12.70	$\frac{3}{8}$ -16
35.05	2.245	57.02	5.13	130.18	8.19	208.03	2.50	63.50	0.75	19.05	$\frac{3}{8}$ -16
44.45	2.245	57.02	5.13	130.18	8.19	208.03	2.50	63.50	0.75	19.05	$\frac{3}{8}$ -16
50.80	2.245	57.02	5.13	130.18	8.19	208.03	2.50	63.50	0.75	19.05	$\frac{3}{8}$ -16
35.05	2.245	57.02	5.31	134.87	6.25	158.75	2.50	63.50	0.50	12.70	$\frac{3}{8}$ -16
44.45	2.245	57.02	5.31	134.87	6.25	158.75	2.50	63.50	0.50	12.70	$\frac{3}{8}$ -16
50.80	2.245	57.02	5.31	134.87	6.25	158.75	2.50	63.50	0.50	12.70	$\frac{3}{8}$ -16
35.05	2.245	57.02	5.31	134.87	6.25	158.75	2.50	63.50	0.50	12.70	$\frac{3}{8}$ -16
44.45	2.245	57.02	5.31	134.87	6.25	158.75	2.50	63.50	0.50	12.70	$\frac{3}{8}$ -16
50.80	2.245	57.02	5.31	134.87	6.25	158.75	2.50	63.50	0.50	12.70	$\frac{3}{8}$ -16
35.05	2.245	57.02	5.31	134.87	6.25	158.75	2.50	63.50	0.50	12.70	$\frac{3}{8}$ -16
44.45	2.245	57.02	5.31	134.87	6.25	158.75	2.50	63.50	0.50	12.70	$\frac{3}{8}$ -16
50.80	2.245	57.02	5.31	134.87	6.25	158.75	2.50	63.50	0.50	12.70	$\frac{3}{8}$ -16
25.40	1.496	38.00	4.56	115.82	6.13	155.70	1.31	33.27	0.50	12.70	1 $\frac{1}{8}$ -18
35.05	1.496	38.00	4.56	115.82	6.13	155.70	1.31	33.27	0.50	12.70	1 $\frac{1}{8}$ -18
25.40	1.496	38.00	4.88	123.83	6.25	158.75	2.50	63.50	0.50	12.70	$\frac{3}{8}$ -16
35.05	2.245	57.02	4.88	123.83	6.25	158.75	2.50	63.50	0.50	12.70	$\frac{3}{8}$ -16
44.45	2.245	57.02	4.88	123.83	6.25	158.75	2.50	63.50	0.50	12.70	$\frac{3}{8}$ -16
50.80	2.245	57.02	4.88	123.83	6.25	158.75	2.50	63.50	0.50	12.70	$\frac{3}{8}$ -16
66.55	2.245	57.02	4.88	123.83	6.25	158.75	2.50	63.50	0.50	12.70	$\frac{3}{8}$ -16
44.45	2.245	57.02	5.13	130.18	8.19	208.03	2.50	63.50	0.75	19.05	$\frac{3}{8}$ -16
50.80	2.245	57.02	5.13	130.18	8.19	208.03	2.50	63.50	0.75	19.05	$\frac{3}{8}$ -16
66.55	2.245	57.02	5.13	130.18	8.19	208.03	2.50	63.50	0.75	19.05	$\frac{3}{8}$ -16
44.45	2.245	57.02	5.31	134.87	6.25	158.75	2.50	63.50	0.50	12.70	$\frac{3}{8}$ -16
50.80	2.245	57.02	5.31	134.87	6.25	158.75	2.50	63.50	0.50	12.70	$\frac{3}{8}$ -16
66.55	2.245	57.02	5.31	134.87	6.25	158.75	2.50	63.50	0.50	12.70	$\frac{3}{8}$ -16
44.45	2.245	57.02	5.31	134.87	8.19	208.03	2.50	63.50	0.50	12.70	$\frac{3}{8}$ -16
50.80	2.245	57.02	5.31	134.87	8.19	208.03	2.50	63.50	0.50	12.70	$\frac{3}{8}$ -16
66.55	2.245	57.02	5.31	134.87	8.19	208.03	2.50	63.50	0.50	12.70	$\frac{3}{8}$ -16
44.45	2.245	57.02	5.31	134.87	6.25	158.75	2.50	63.50	0.50	12.70	$\frac{3}{8}$ -16
50.80	2.245	57.02	5.31	134.87	6.25	158.75	2.50	63.50	0.50	12.70	$\frac{3}{8}$ -16
66.55	2.245	57.02	5.31	134.87	6.25	158.75	2.50	63.50	0.50	12.70	$\frac{3}{8}$ -16
44.45	2.245	57.02	5.31	134.87	6.25	158.75	2.50	63.50	0.50	12.70	$\frac{3}{8}$ -16
50.80	2.245	57.02	5.31	134.87	6.25	158.75	2.50	63.50	0.50	12.70	$\frac{3}{8}$ -16
66.55	2.245	57.02	5.31	134.87	6.25	158.75	2.50	63.50	0.50	12.70	$\frac{3}{8}$ -16

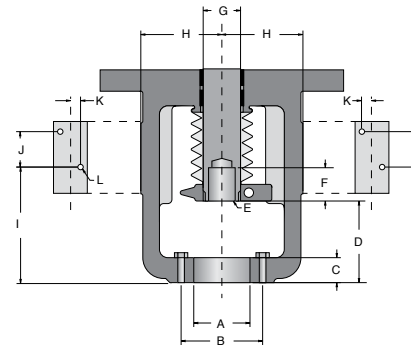

Mounting Dimensions, VL-C, VL-ES (Continued)

Actuator Size	Spud Size		Max Stroke Length		Stem Thread	Bolt Circle		Mounting Bolts		Spud Thickness		Stem Extended		Stem Thread Depth
	A		in.	mm	E	B		Size	Qty	C		D		F
	in.	mm				in.	mm			in.	mm	in.	mm	
150	4.75	120.65	8.00	203.20	1½-12	6.50	165.10	.625-11	6	1.50	38.10	4.88	123.95	1.75
	4.75	120.65	8.00	203.20	1½-12	6.50	165.10	.625-11	6	1.50	38.10	4.88	123.95	2.00
	4.75	120.65	8.00	203.20	2-12	6.50	165.10	.625-11	6	1.50	38.10	4.88	123.95	2.62
200	3.38	85.85	4.00	101.60	1-12	5.00	127.00	.625-11	6	1.50	38.10	4.88	123.95	1.38
	3.38	85.85	4.00	101.60	1½-12	5.00	127.00	.625-11	6	1.50	38.10	4.88	123.95	1.75
	3.38	85.85	4.00	101.60	1½-12	5.00	127.00	.625-11	6	1.50	38.10	4.88	123.95	2.00
	3.38	85.85	4.00	101.60	2-12	5.00	127.00	.625-11	6	1.50	38.10	4.88	123.95	2.62
	3.38	85.85	8.00	203.20	1½-12	5.00	127.00	.625-11	6	1.50	38.10	4.88	123.95	1.75
	3.38	85.85	8.00	203.20	1½-12	5.00	127.00	.625-11	6	1.50	38.10	4.88	123.95	2.00
	3.38	85.85	8.00	203.20	2-12	5.00	127.00	.625-11	6	1.50	38.10	4.88	123.95	2.62
	4.00	101.60	4.00	101.60	1½-12	5.75	146.05	.625-11	6	1.50	38.10	4.88	123.95	1.75
	4.00	101.60	4.00	101.60	1½-12	5.75	146.05	.625-11	6	1.50	38.10	4.88	123.95	2.00
	4.00	101.60	4.00	101.60	2-12	5.75	146.05	.625-11	6	1.50	38.10	4.88	123.95	2.62
	4.00	101.60	8.00	203.20	1½-12	5.75	146.05	.625-11	6	1.50	38.10	4.88	123.95	1.75
	4.00	101.60	8.00	203.20	1½-12	5.75	146.05	.625-11	6	1.50	38.10	4.88	123.95	2.00
	4.00	101.60	8.00	203.20	2-12	5.75	146.05	.625-11	6	1.50	38.10	4.88	123.95	2.62
	4.75	120.65	4.00	101.60	1½-12	6.50	165.10	.625-11	6	1.50	38.10	4.88	123.95	1.75
	4.75	120.65	4.00	101.60	1½-12	6.50	165.10	.625-11	6	1.50	38.10	4.88	123.95	2.00
4.75	120.65	4.00	101.60	2-12	6.50	165.10	.625-11	6	1.50	38.10	4.88	123.95	2.62	
4.75	120.65	8.00	203.20	1½-12	6.50	165.10	.625-11	6	1.50	38.10	4.88	123.95	1.75	
4.75	120.65	8.00	203.20	1½-12	6.50	165.10	.625-11	6	1.50	38.10	4.88	123.95	2.00	
4.75	120.65	8.00	203.20	2-12	6.50	165.10	.625-11	6	1.50	38.10	4.88	123.95	2.62	
300	3.38	85.85	4.00	101.60	1½-12	4.88	123.95	.750-10	6	1.50	38.10	4.88	123.95	1.75
	3.38	85.85	4.00	101.60	1½-12	4.88	123.95	.750-10	6	1.50	38.10	4.88	123.95	2.00
	3.38	85.85	4.00	101.60	2-12	4.88	123.95	.750-10	6	1.50	38.10	4.88	123.95	2.62
	3.38	85.85	8.00	203.20	1½-12	4.88	123.95	.750-10	6	1.50	38.10	4.88	123.95	1.75
	3.38	85.85	8.00	203.20	1½-12	4.88	123.95	.750-10	6	1.50	38.10	4.88	123.95	2.00
	3.38	85.85	8.00	203.20	2-12	4.88	123.95	.750-10	6	1.50	38.10	4.88	123.95	2.62
	4.00	101.60	4.00	101.60	1½-12	6.50	165.10	.750-10	8	1.50	38.10	4.88	123.95	1.75
	4.00	101.60	4.00	101.60	1½-12	6.50	165.10	.750-10	8	1.50	38.10	4.88	123.95	2.00
	4.00	101.60	4.00	101.60	2-12	6.50	165.10	.750-10	8	1.50	38.10	4.88	123.95	2.62
	4.00	101.60	8.00	203.20	1½-12	6.50	165.10	.750-10	8	1.50	38.10	4.88	123.95	1.75
	4.00	101.60	8.00	203.20	1½-12	6.50	165.10	.750-10	8	1.50	38.10	4.88	123.95	2.00
	4.00	101.60	8.00	203.20	2-12	6.50	165.10	.750-10	8	1.50	38.10	4.88	123.95	2.62
	4.75	120.65	4.00	101.60	1½-12	6.50	165.10	.750-10	8	1.50	38.10	4.88	123.95	1.75
	4.75	120.65	4.00	101.60	1½-12	6.50	165.10	.750-10	8	1.50	38.10	4.88	123.95	2.00
	4.75	120.65	4.00	101.60	2-12	6.50	165.10	.750-10	8	1.50	38.10	4.88	123.95	2.62
4.75	120.65	8.00	203.20	1½-12	6.50	165.10	.750-10	8	1.50	38.10	4.88	123.95	1.75	
4.75	120.65	8.00	203.20	1½-12	6.50	165.10	.750-10	8	1.50	38.10	4.88	123.95	2.00	
4.75	120.65	8.00	203.20	2-12	6.50	165.10	.750-10	8	1.50	38.10	4.88	123.95	2.62	
400	4.75	120.65	4.00	101.60	1½-12	6.50	165.10	.750-10	8	1.50	38.10	4.88	123.95	1.75
	4.75	120.65	4.00	101.60	1½-12	6.50	165.10	.750-10	8	1.50	38.10	4.88	123.95	2.00
	4.75	120.65	4.00	101.60	2-12	6.50	165.10	.750-10	8	1.50	38.10	4.88	123.95	2.62
	4.75	120.65	8.00	203.20	1½-12	6.50	165.10	.750-10	8	1.50	38.10	4.88	123.95	1.75
	4.75	120.65	8.00	203.20	1½-12	6.50	165.10	.750-10	8	1.50	38.10	4.88	123.95	2.00

(1) Dimension may change when using a side mounted handwheel. Contact the Factory for details when using side mounted handwheels.

Stem Thread Depth	Stem Diameter		Mounting Pad Offset		Mounting Pad Hole Height ⁽¹⁾		Mounting Pad Hole Spacing		Mounting Pad Hole Spacing		Mounting Pad Bolt Size
	F	G	H		I		J		K		
mm	in.	mm	in.	mm	in.	mm	in.	mm	in.	mm	L
44.45	2.245	57.02	5.31	134.87	8.19	208.03	2.50	63.50	0.50	12.70	3/8-16
50.80	2.245	57.02	5.31	134.87	8.19	208.03	2.50	63.50	0.50	12.70	3/8-16
66.55	2.245	57.02	5.31	134.87	8.19	208.03	2.50	63.50	0.50	12.70	3/8-16
35.05	2.245	57.02	5.13	130.18	6.19	157.23	2.50	63.50	0.50	12.70	3/8-16
44.45	2.245	57.02	5.13	130.18	6.19	157.23	2.50	63.50	0.50	12.70	3/8-16
50.80	2.245	57.02	5.13	130.18	6.19	157.23	2.50	63.50	0.50	12.70	3/8-16
66.55	2.245	57.02	5.13	130.18	6.19	157.23	2.50	63.50	0.50	12.70	3/8-16
44.45	2.245	57.02	5.75	146.05	8.19	208.03	2.50	63.50	0.50	12.70	3/8-16
50.80	2.245	57.02	5.75	146.05	8.19	208.03	2.50	63.50	0.75	19.05	3/8-16
66.55	2.245	57.02	5.75	146.05	8.19	208.03	2.50	63.50	0.75	19.05	3/8-16
44.45	2.245	57.02	5.75	146.05	6.19	157.23	2.50	63.50	0.50	12.70	3/8-16
50.80	2.245	57.02	5.75	146.05	6.19	157.23	2.50	63.50	0.50	12.70	3/8-16
66.55	2.245	57.02	5.75	146.05	6.19	157.23	2.50	63.50	0.50	12.70	3/8-16
44.45	2.245	57.02	5.75	146.05	8.19	208.03	2.50	63.50	0.50	12.70	3/8-16
50.80	2.245	57.02	5.75	146.05	8.19	208.03	2.50	63.50	0.50	12.70	3/8-16
66.55	2.245	57.02	5.75	146.05	8.19	208.03	2.50	63.50	0.50	12.70	3/8-16
44.45	2.245	57.02	5.75	146.05	8.19	208.03	2.50	63.50	0.75	19.05	3/8-16
50.80	2.245	57.02	5.75	146.05	8.19	208.03	2.50	63.50	0.75	19.05	3/8-16
66.55	2.245	57.02	5.75	146.05	8.19	208.03	2.50	63.50	0.75	19.05	3/8-16
44.45	2.745	69.72	5.75	146.05	6.19	157.23	2.50	63.50	0.75	19.05	3/8-16
50.80	2.745	69.72	5.75	146.05	6.19	157.23	2.50	63.50	0.75	19.05	3/8-16
66.55	2.745	69.72	5.75	146.05	6.19	157.23	2.50	63.50	0.75	19.05	3/8-16
44.45	2.745	69.72	5.75	146.05	8.19	208.03	2.50	63.50	0.75	19.05	3/8-16
50.80	2.745	69.72	5.75	146.05	8.19	208.03	2.50	63.50	0.75	19.05	3/8-16
66.55	2.745	69.72	5.75	146.05	8.19	208.03	2.50	63.50	0.75	19.05	3/8-16
44.45	2.745	69.72	5.75	146.05	8.19	208.03	2.50	63.50	0.75	19.05	3/8-16
50.80	2.745	69.72	5.75	146.05	8.19	208.03	2.50	63.50	0.75	19.05	3/8-16
66.55	2.745	69.72	5.75	146.05	8.19	208.03	2.50	63.50	0.75	19.05	3/8-16
44.45	2.745	69.72	5.75	146.05	8.19	208.03	2.50	63.50	0.75	19.05	3/8-16
50.80	2.745	69.72	5.75	146.05	8.19	208.03	2.50	63.50	0.75	19.05	3/8-16
66.55	2.745	69.72	5.75	146.05	8.19	208.03	2.50	63.50	0.75	19.05	3/8-16
44.45	2.745	69.72	5.75	146.05	8.19	208.03	2.50	63.50	0.75	19.05	3/8-16
50.80	2.745	69.72	5.75	146.05	8.19	208.03	2.50	63.50	0.75	19.05	3/8-16
66.55	2.745	69.72	5.75	146.05	8.19	208.03	2.50	63.50	0.75	19.05	3/8-16
44.45	2.745	69.72	5.75	146.05	8.19	208.03	2.50	63.50	0.75	19.05	3/8-16
50.80	2.745	69.72	5.75	146.05	8.19	208.03	2.50	63.50	0.75	19.05	3/8-16
66.55	2.745	69.72	5.75	146.05	8.19	208.03	2.50	63.50	0.75	19.05	3/8-16
44.45	2.745	69.72	5.75	146.05	8.19	208.03	2.50	63.50	0.75	19.05	3/8-16
50.80	2.745	69.72	5.75	146.05	8.19	208.03	2.50	63.50	0.75	19.05	3/8-16
66.55	2.745	69.72	5.75	146.05	8.19	208.03	2.50	63.50	0.75	19.05	3/8-16

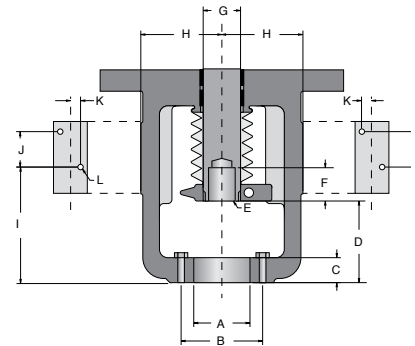

Unbalanced Valve Actuator Dimensions

Actuator Design	Cyl. Size	Body Size (in.)				Spring	Spud Diameter		G		J		K		Beta
		Unbalanced Valves		Balanced Valves			in.	mm	in.	mm	in.	mm	in.	mm	
		Class 150-600	Class 900-2500	Class 150-600	Class 900-2500										
VL	25	.5 to 2	.5 to 1	.5 to 2	.5 to 1	Independent	2.00	14.7	373.38	6.5	165.1	7.4	187.96		
	50	.5 to 2	.5 to 1	.5 to 2	.5 to 1		2.00	18.8	477.52	9.1	231.14	8.7	220.98		
		3 to 4, 6 ⁽¹⁾	1.5 to 2	3 to 4, 6 ⁽¹⁾	1.5 to 2		2.62	21.1	535.94	9.1	231.14	6.6	167.64		
	100	3 to 4, 6 ⁽¹⁾	1.5 to 2	3 to 4, 6 ⁽¹⁾	1.5 to 2		2.62 - 2.88	26	660.4	12.5	317.5	9.9	251.46		
		6 ⁽²⁾ , 8, 10 ⁽¹⁾ , 12 ⁽¹⁾	3 to 4	6 ⁽²⁾ , 8, 10 ⁽¹⁾ , 12 ⁽¹⁾	3 to 4		3.38	27	685.8	12.5	317.5	10.4	264.16		
	200	10 ⁽²⁾ , 12 ⁽²⁾ to 14	6 +	10 ⁽²⁾ , 12 ⁽²⁾ to 14	6 +		4.00 - 4.75	27	685.8	12.5	317.5	10.8	274.32		
		3 to 4, 6 ⁽¹⁾	0.5 to 2	3 to 4, 6 ⁽¹⁾	0.5 to 2		2.62 - 2.88	26.6	675.64	17.5	444.5	9.9	251.46		
	300	6 ⁽²⁾ , 8, 10 ⁽¹⁾ , 12 ⁽¹⁾	3 to 4	6 ⁽²⁾ , 8, 10 ⁽¹⁾ , 12 ⁽¹⁾	3 to 4		3.38	27.6	701.04	17.5	444.5	10.4	264.16		
		10 ⁽²⁾ , 12 ⁽²⁾ to 14	6 +	10 ⁽²⁾ , 12 ⁽²⁾ to 14	6 +		4.00 - 4.75	27.6	701.04	17.5	444.5	10.8	274.32		
	400	6 +	6 +	6 +	6 +		3.38 - 4.75	30.5	774.7	21.8	553.72	11.1	281.94		
500	6 +	6 +	6 +	6 +	3.38 - 4.75	36.6	929.64	18	457.2	10.7	271.78				
600	6 +	6 +	6 +	6 +	3.38 - 4.75	31	787.4	28	711.2	11.1	281.94				
VL-C	25	.5 to 2	.5 to 1	.5 to 2	.5 to 1	Independent	2.00	14.7	373.38	6.3	160.02	7.4	187.96		
	50	.5 to 2	.5 to 1	.5 to 2	.5 to 1		2.00	18.8	477.52	8.6	218.44	8.7	220.98		
		3 to 4, 6 ⁽¹⁾	1.5 to 2	3 to 4, 6 ⁽¹⁾	1.5 to 2		2.62	21.1	535.94	8.6	218.44	8.7	220.98		
	100	3 to 4, 6 ⁽¹⁾	1.5 to 2	3 to 4, 6 ⁽¹⁾	1.5 to 2		2.88	26.8	680.72	14.8	375.92	9.9	251.46		
		6 ⁽²⁾ , 8, 10 ⁽¹⁾ , 12 ⁽¹⁾	3 to 4	6 ⁽²⁾ , 8, 10 ⁽¹⁾ , 12 ⁽¹⁾	3 to 4		3.38	27.8	706.12	14.8	375.92	10.4	264.16		
	150	10 ⁽²⁾ , 12 ⁽²⁾ to 14	6 +	10 ⁽²⁾ , 12 ⁽²⁾ to 14	6 +		4.00 - 4.75	27.8	706.12	14.8	375.92	10.8	274.32		
		3 to 4, 6 ⁽¹⁾	0.5 to 2	3 to 4, 6 ⁽¹⁾	0.5 to 2		2.88	26.8	680.72	17.1	434.34	9.9	251.46		
	200	6 ⁽²⁾ , 8, 10 ⁽¹⁾ , 12 ⁽¹⁾	3 to 4	6 ⁽²⁾ , 8, 10 ⁽¹⁾ , 12 ⁽¹⁾	3 to 4		3.38	27.8	706.12	17.1	434.34	10.4	264.16		
		10 ⁽²⁾ , 12 ⁽²⁾ to 14	6 +	10 ⁽²⁾ , 12 ⁽²⁾ to 14	6 +		4.00 - 4.75	27.8	706.12	17.1	434.34	10.4	264.16		
	VL-UHC	25	.5 to 2	.5 to 1	.5 to 2		.5 to 1	Independent	2.00	14.7	373.38	6.5	165.1	7.4	187.96
50		.5 to 2	.5 to 1	.5 to 2	.5 to 1	2.00	18.8		477.52	9.1	231.14	8.7	220.98		
		3 to 4, 6 ⁽¹⁾	1.5 to 2	3 to 4, 6 ⁽¹⁾	1.5 to 2	2.62	21.1		535.94	9.1	231.14	6.6	167.64		
100		3 to 4, 6 ⁽¹⁾	1.5 to 2	3 to 4, 6 ⁽¹⁾	1.5 to 2	2.62 - 2.88	26		660.4	12.5	317.5	9.9	251.46		
		6 ⁽²⁾ , 8, 10 ⁽¹⁾ , 12 ⁽¹⁾	3 to 4	6 ⁽²⁾ , 8, 10 ⁽¹⁾ , 12 ⁽¹⁾	3 to 4	3.38	27		685.8	12.5	317.5	10.4	264.16		
200		10 ⁽²⁾ , 12 ⁽²⁾ to 14	6 +	10 ⁽²⁾ , 12 ⁽²⁾ to 14	6 +	4.00 - 4.75	27		685.8	12.5	317.5	10.8	274.32		
		3 to 4, 6 ⁽¹⁾	0.5 to 2	3 to 4, 6 ⁽¹⁾	0.5 to 2	2.62 - 2.88	26.6		675.64	17.5	444.5	9.9	251.46		
VL-ES		100	6 ⁽²⁾ , 8, 10 ⁽¹⁾ , 12 ⁽¹⁾	3 to 4	6 ⁽²⁾ , 8, 10 ⁽¹⁾ , 12 ⁽¹⁾	3 to 4	Standard		3.38	27.6	701.04	17.5	444.5	10.4	264.16
			10 ⁽²⁾ , 12 ⁽²⁾ to 14	6 +	10 ⁽²⁾ , 12 ⁽²⁾ to 14	6 +			4.00 - 4.75	27.6	701.04	17.5	444.5	10.8	274.32
		150	6 ⁽²⁾ , 8, 10 ⁽¹⁾ , 12 ⁽¹⁾	3, 4 ⁽³⁾	6 ⁽²⁾ , 8, 10	3 ⁽⁴⁾ , 4, 6 ⁽³⁾ , 8 ⁽³⁾	Standard		3.38	35.0	889	14.8	375.92	10.8	274.32
	10 ⁽²⁾ , 12 ⁽²⁾ , 14		4 ⁽⁴⁾ , 6 ⁽³⁾	12, 14	6 ⁽⁴⁾ , 8 ⁽⁴⁾ , 10+	4		35.0	889	14.8	375.92	11.2	284.48		
	200	6 ⁽¹⁾ , 8, 10 ⁽¹⁾ , 12 ⁽¹⁾	3, 4 ⁽³⁾	6 ⁽²⁾ , 8, 10	3 ⁽⁴⁾ , 4, 6 ⁽³⁾ , 8 ⁽³⁾	Heavy Duty	3.38	39.5	1003.3	14.8	375.92	10.8	274.32		
		10 ⁽²⁾ , 12 ⁽²⁾ , 14	4 ⁽⁴⁾ , 6 ⁽³⁾	12, 14	6 ⁽⁴⁾ , 8 ⁽⁴⁾ , 10+		4	39.5	1003.3	14.8	375.92	11.2	284.48		
	300	6 ⁽²⁾ , 8, 10 ⁽¹⁾ , 12 ⁽¹⁾	3, 4 ⁽³⁾	6 ⁽²⁾ , 8, 10	3 ⁽⁴⁾ , 4, 6 ⁽³⁾ , 8 ⁽³⁾	Standard	3.38	35.0	889	17.1	434.34	10.8	274.32		
		10 ⁽²⁾ , 12 ⁽²⁾ , 14	4 ⁽⁴⁾ , 6 ⁽³⁾	12, 14	6 ⁽⁴⁾ , 8 ⁽⁴⁾ , 10+		4	35.0	889	17.1	434.34	11.2	284.48		
	400	6 ⁽²⁾ , 8, 10 ⁽¹⁾ , 12 ⁽¹⁾	3, 4 ⁽³⁾	6 ⁽²⁾ , 8, 10	3 ⁽⁴⁾ , 4, 6 ⁽³⁾ , 8 ⁽³⁾	Heavy Duty	3.38	39.5	1003.3	17.1	434.34	10.8	274.32		
		10 ⁽²⁾ , 12 ⁽²⁾ , 14	4 ⁽⁴⁾ , 6 ⁽³⁾	12, 14	6 ⁽⁴⁾ , 8 ⁽⁴⁾ , 10+		4	39.5	1003.3	17.1	434.34	11.2	284.48		

(1) Class 150 Only
 (2) Class 300 and 600 Only
 (3) Class 900 and 1500 Only
 (4) Class 2500 Only
 (5) Size 300 and 400 VL-ES actuators utilize a split stem clamp

XL	Beta I/P, XL I/P						Logix 3000 Series				Disassembly Clearance		Maximum Stroke Length	
	L		K		L		K		L					
	in.	mm	in.	mm	in.	mm	in.	mm	in.	mm	in.	mm	in.	mm
4.9	124.46	9.7	246.38	6.6	167.64	8.5	215.9	6.8	172.72	5.38	137	1.5	38.1	
4.6	116.84	11.0	279.4	6.3	160.02	9.4	238.76	7.4	187.96	5.38	137	1.5	38.1	
4.6	116.84	8.9	226.06	6.3	160.02	9.5	241.3	7.0	177.8	11.5	292	3.0	76.2	
4.5	114.3	12.2	309.88	6.2	157.48	10.5	266.7	7.5	190.5	11.5	292	4.0	101.6	
4.2	106.68	12.7	322.58	5.9	149.86	11.0	279.4	7.8	198.12	14.5	368	4.0	101.6	
4.2	106.68	13.1	332.74	5.9	149.86	11.5	292.1	7.8	198.12	14.5	368	4.0	101.6	
4.5	114.3	12.2	309.88	6.2	157.48	9.25	234.95	8.2	208.28	11.5	292	4.0	101.6	
4.2	106.68	12.7	322.58	5.9	149.86	11.0	279.4	7.8	198.12	14.5	368	4.0	101.6	
4.2	106.68	13.1	332.74	5.9	149.86	11.5	292.1	7.8	198.12	14.5	368	4.0	101.6	
4.1	104.14	13.4	340.36	5.8	147.32	11.6	294.64	7.7	195.58	14.5	368	4.0	101.6	
4.5	114.3	13	330.2	6.2	157.48	10.8	274.32	7.4	187.96	14.5	368	4.0	101.6	
4.1	104.14	13.4	340.36	5.8	147.32	12.5	317.5	7.8	198.12	14.5	368	4.0	101.6	
4.1	104.14	13.4	340.36	5.8	147.32	11.6	294.64	7.7	195.58	14.5	368	4.0	101.6	
4.9	124.46	9.7	246.38	6.6	167.64	8.5	215.9	6.8	172.72	5.38	137	1.5	38.1	
4.6	116.84	11	279.4	6.3	160.02	9.4	238.76	7.4	187.96	5.38	137	1.5	38.1	
4.6	116.84	8.9	226.06	6.3	160.02	9.5	241.3	7.0	177.8	11.5	292	3.0	76.2	
4.5	114.3	12.2	309.88	6.2	157.48	10.5	266.7	7.5	190.5	11.5	292	4.0	101.6	
4.2	106.68	12.7	322.58	5.9	149.86	11.0	279.4	7.8	198.12	14.5	368	4.0	101.6	
4.2	106.68	13.1	332.74	5.9	149.86	11.5	292.1	7.8	198.12	14.5	368	4.0	101.6	
4.5	114.3	12.2	309.88	6.2	157.48	9.25	234.95	8.2	208.28	11.5	292	4.0	101.6	
4.2	106.68	12.7	322.58	5.9	149.86	11.0	279.4	7.8	198.12	14.5	368	4.0	101.6	
4.2	106.68	12.7	322.58	5.9	149.86	11.5	292.1	7.8	198.12	14.5	368	4.0	101.6	
4.1	104.14	13.4	340.36	5.8	147.32	10.45	265.43	7.8	198.12	11.5	292	4.0	101.6	
4.1	104.14	13.4	340.36	5.8	147.32	10.5	265.43	7.8	198.12	14.5	368	4.0	101.6	
4.1	104.14	13.4	340.36	5.8	147.32	10.45	265.43	7.8	198.12	14.5	368	4.0	101.6	
4.9	124.46	9.7	246.38	6.6	167.64	8.5	215.9	6.8	172.72	5.38	137	1.5	38.1	
4.6	116.84	11	279.4	6.3	160.02	9.4	238.76	7.4	187.96	5.38	137	1.5	38.1	
4.6	116.84	8.9	226.06	6.3	160.02	9.5	241.3	7.0	177.8	11.5	292	3.0	76.2	
4.5	114.3	12.2	309.88	6.2	157.48	10.5	266.7	7.5	190.5	11.5	292	4.0	101.6	
4.2	106.68	12.7	322.58	5.9	149.86	11.0	279.4	7.8	198.12	14.5	368	4.0	101.6	
4.2	106.68	13.1	332.74	5.9	149.86	11.5	292.1	7.8	198.12	14.5	368	4.0	101.6	
4.5	114.3	12.2	309.88	6.2	157.48	9.25	234.95	8.2	208.28	11.5	292	4.0	101.6	
4.2	106.68	12.7	322.58	5.9	149.86	11.0	279.4	7.8	198.12	14.5	368	4.0	101.6	
4.2	106.68	13.1	332.74	5.9	149.86	11.5	292.1	7.8	198.12	14.5	368	4.0	101.6	
4.5	114.3	13.1	332.74	6.2	157.48	11.38	289.052	7.8	198.12	14.5	368	4.0	101.6	
4.2	106.68	13.5	342.9	5.9	149.86	11.8	299.974	7.8	198.12	12.2	309	4.0	101.6	
4.2	106.68	13.5	342.9	5.9	149.86	11.81	299.974	7.8	198.12	14.5	368	4.0	101.6	
4.1	104.14	13.1	332.74	5.8	147.32	11.38	289.052	7.8	198.12	14.5	368	4.0	101.6	
4.1	104.14	13.5	342.9	5.8	147.32	11.8	299.974	7.8	198.12	12.2	309	4.0	101.6	
4.1	104.14	13.5	342.9	5.8	147.32	11.81	299.974	7.8	198.12	14.5	368	4.0	101.6	
4.5	114.3	13.1	332.74	6.2	157.48	11.38	289.052	7.8	198.12	14.5	368	4.0	101.6	
4.2	106.68	13.5	342.9	5.9	149.86	11.8	299.974	7.8	198.12	12.2	309	4.0	101.6	
4.2	106.68	13.5	342.9	5.9	149.86	11.81	299.974	7.8	198.12	14.5	368	4.0	101.6	
4.1	104.14	13.1	332.74	5.8	147.32	11.38	289.052	7.8	198.12	14.5	368	4.0	101.6	
4.1	104.14	13.5	342.9	5.8	147.32	11.8	299.974	7.8	198.12	12.2	309	4.0	101.6	
4.1	104.14	13.5	342.9	5.8	147.32	11.81	299.974	7.8	198.12	14.5	368	4.0	101.6	
4.1	104.14	15.2	386.08	5.8	147.32	12.25	311.15	7.8	198.12	14.5	368	4.0	101.6	
4.1	104.14	15.2	386.08	5.8	147.32	12.25	311.15	7.8	198.12	12.2	309	4.0	101.6	
4.1	104.14	15.2	386.08	5.8	147.32	12.25	311.15	7.8	198.12	14.5	368	4.0	101.6	
4.1	104.14	15.2	386.08	5.8	147.32	12.25	311.15	7.8	198.12	14.5	368	4.0	101.6	
4.1	104.14	15.2	386.08	5.8	147.32	12.25	311.15	7.8	198.12	12.2	309	4.0	101.6	
4.1	104.14	15.2	386.08	5.8	147.32	12.25	311.15	7.8	198.12	14.5	368	4.0	101.6	
4.1	104.14	15.2	386.08	5.8	147.32	12.25	311.15	7.8	198.12	14.5	368	4.0	101.6	
4.1	104.14	15.2	386.08	5.8	147.32	12.25	311.15	7.8	198.12	12.2	309	4.0	101.6	
4.1	104.14	15.2	386.08	5.8	147.32	12.25	311.15	7.8	198.12	14.5	368	4.0	101.6	
4.1	104.14	15.2	386.08	5.8	147.32	12.25	311.15	7.8	198.12	14.5	368	4.0	101.6	
4.1	104.14	15.2	386.08	5.8	147.32	12.25	311.15	7.8	198.12	12.2	309	4.0	101.6	
4.1	104.14	15.2	386.08	5.8	147.32	12.25	311.15	7.8	198.12	14.5	368	4.0	101.6	
4.1	104.14	15.2	386.08	5.8	147.32	12.25	311.15	7.8	198.12	14.5	368	4.0	101.6	
4.1	104.14	15.2	386.08	5.8	147.32	12.25	311.15	7.8	198.12	12.2	309	4.0	101.6	

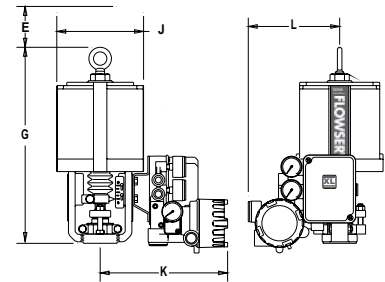

VL with a Beta VP, XL VP

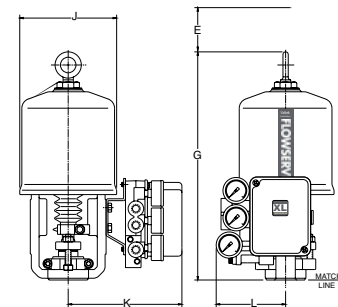

VL-C size 25 and 50 with a Beta or XL positioner

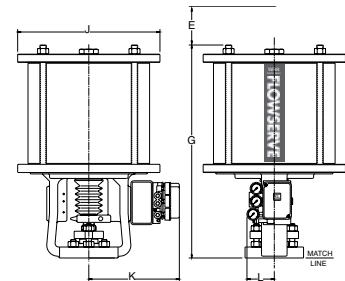

VL-C size 100 and larger with a Beta or XL positioner

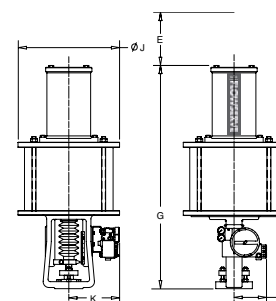

VL-ES with a Logix series 3000 positioner



United States
Flowserve Corporation
Flowserve Flow Control
Valtek Control Products
1350 N. Mtn. Springs Prkwy.
Springville, UT 84663
Phone 801 489 8611
Facsimile 801 489 3719

***To find your local Flowserve representative,
visit www.flowserve.com or call USA 1 800 225 6989***

FCD VLATB0002-15 Printed in USA.

Flowserve Corporation has established industry leadership in the design and manufacture of its products. When properly selected, this Flowserve product is designed to perform its intended function safely during its useful life. However, the purchaser or user of Flowserve products should be aware that Flowserve products might be used in numerous applications under a wide variety of industrial service conditions. Although Flowserve can (and often does) provide general guidelines, it cannot provide specific data and warnings for all possible applications. The purchaser/user must therefore assume the ultimate responsibility for the proper sizing and selection, installation, operation, and maintenance of Flowserve products. The purchaser/user should read and understand the Installation Operation Maintenance (IOM) instructions included with the product, and train its employees and contractors in the safe use of Flowserve products in connection with the specific application.

While the information and specifications contained in this literature are believed to be accurate, they are supplied for informative purposes only and should not be considered certified or as a guarantee of satisfactory results by reliance thereon. Nothing contained herein is to be construed as a warranty or guarantee, express or implied, regarding any matter with respect to this product. Because Flowserve is continually improving and upgrading its product design, the specifications, dimensions and information contained herein are subject to change without notice. Should any question arise concerning these provisions, the purchaser/user should contact Flowserve Corporation at any one of its worldwide operations or offices.

© 2007 Flowserve Corporation, Irving, Texas, USA. Flowserve is a registered trademark of Flowserve Corporation.