

3200IQ Digital Positioner

Installation, Operation and Maintenance Instructions



Contents

1	Terms Concerning Safety	4
2	General Information	4
3	Unpacking and Storage	4
3.1	Unpacking	4
3.2	Storage	4
3.3	Pre-installation Inspection	4
4	Logix 3200/Q Positioner Overview	5
4.1	Specifications	5
4.2	Positioner Operation	6
4.3	Detailed Sequence of Positioner Operations	7
5	Mounting and Installation	8
5.1	Mounting to Valtek Linear Mark One Valves	8
5.2	Mounting to Standard Valtek Rotary Valves	10
5.3	Optional Valtek Rotary Mounting Procedure	11
5.4	Tubing Positioner to Actuator	12
6	Wiring and Grounding Guidelines	12
6.1	4-20 mA Command Input Wiring	13
6.2	Grounding Screw	13
6.3	Compliance Voltage	13
6.4	Cable Requirements	13
6.5	Intrinsically Safe Barriers	14
7	Startup	14
7.1	Logix 3200/Q Local Interface Operation	14
7.2	Initial DIP Switch Settings	14
7.3	Description of Configuration DIP Switch Settings	15
7.4	Description of Cal DIP Switch Settings	16
7.5	QUICK-CAL Operation	16
7.6	Manual Jog Calibration Operation	17
7.7	Local Control of Valve Position	17
7.8	Factory Reset	17
7.9	Command Source Reset	17
7.10	Logix 3200/Q Status Condition	17
7.11	Version Number Checking	19
7.12	SoftTools™ Configuration and Diagnostic Software and HART 275/375 Handheld Communicator	20
8	Maintenance and Repair	20
8.1	Driver Module Assembly	20
8.2	Regulator	23

8.3	Checking or Setting Internal Regulator Pressure	23
8.4	Spool Valve	24
8.5	Spool Valve Cover	24
8.6	Stem Position Sensor	25
8.7	Main PCB Assembly	25
8.8	Pressure Sensor Board	27
8.9	Customer Interface Board	28
9	Optional Hardware	28
9.1	Vented Design	28
9.2	HART VHF Filter	29
9.3	HART Modem	30
9.4	4-20 mA Analog Output Board	30
10	Parts List	32
11	Logix 3200/Q Spare Parts Kits	34
12	Logix 3200/Q Mounting Kits	35
12.1	Valtek Mounting Kits	35
12.2	Logix O.E.M. Mounting Kits	36
12.3	NAMUR Accessory Mounting Kit Part Numbers	36
13	Frequently Asked Questions	37
14	How to Order	38
15	Troubleshooting	39

1 Terms Concerning Safety

The safety terms DANGER, WARNING, CAUTION and NOTE are used in these instructions to highlight particular dangers and/or to provide additional information on aspects that may not be readily apparent.

DANGER: Indicates that death, severe personal injury and/or substantial property damage will occur if proper precautions are not taken.

WARNING: Indicates that death, severe personal injury and/or substantial property damage can occur if proper precautions are not taken.

CAUTION: Indicates that minor personal injury and/or property damage can occur if proper precautions are not taken.

NOTE: indicates and provides additional technical information, which may not be very obvious even to qualified personnel. Compliance with other, not particularly emphasized notes, with regard to transport, assembly, operation and maintenance and with regard to technical documentation (e.g., in the operating instruction, product documentation or on the product itself) is essential, in order to avoid faults, which in themselves might directly or indirectly cause severe personal injury or property damage.

2 General Information

The following instructions are designed to assist in unpacking, installing and performing maintenance as required on Valtek® Logix® 3200/Q digital positioners. Series 3000 is the term used for all the positioners herein; however, specific numbers indicate features specific to model (i.e., Logix 3200 indicates that the positioner has HART® protocol). See Logix 3200/Q Model Number table in this manual for a breakdown of specific model numbers. Product users and maintenance personnel should thoroughly review this bulletin prior to installing, operating, or performing any maintenance on the valve.

Separate Valtek Flow Control Products Installation, Operation, Maintenance instructions cover the valve (such as IOM 1 or IOM 27) and actuator (such as IOM 2 or IOM 31) portions of the system and other accessories. Refer to the appropriate instructions when this information is needed.

To avoid possible injury to personnel or damage to valve parts, WARNING and CAUTION notes must be strictly followed. Modifying this product, substituting non-factory parts or using maintenance procedures other than outlined could drastically affect performance and be hazardous to personnel and equipment, and may void existing warranties.

WARNING: Standard industry safety practices must be adhered to when working on this or any process control product. Specifically, personal protective and lifting devices must be used as warranted.

3 Unpacking and Storage

3.1 Unpacking

1. While unpacking the Logix 3200/Q positioner, check the packing list against the materials received. Lists describing the system and accessories are included in each shipping container.
2. When lifting the system from the shipping container, position lifting straps to avoid damage to mounted accessories. Systems with valves up to six inches may be lifted by actuator lifting ring. On larger systems, lift unit using lifting straps or hooks through the yoke legs and outer end of body.

WARNING: When lifting a valve/actuator assembly with lifting straps, be aware the center of gravity may be above the lifting point. Therefore, support must be given to prevent the valve/actuator from rotating. Failure to do so can cause serious injury to personnel or damage to nearby equipment.

3. In the event of shipping damage, contact the shipper immediately.
4. Should any problems arise, contact a Flowserve Flow Control Division representative.

3.2 Storage

Control valve packages (a control valve and its instrumentation) can be safely stored in an enclosed building that affords environmental protection; heating is not required. Control valve packages must be stored on suitable skids, not directly on the floor. The storage location must also be free from flooding, dust, dirt, etc.

3.3 Pre-installation Inspection

If a valve control package has been stored for more than one year, inspect one actuator by disassembling it per the appropriate Installation, Operation, and Maintenance Instructions (IOM) prior to valve installation. If O-rings are out-of-round, deteriorated, or both, they must be replaced and the actuator rebuilt. All actuators must then be disassembled and inspected. If the actuator O-rings are replaced, complete the following steps:

1. Replace the pressure-balance plug O-rings.
2. Inspect the solenoid and positioner soft goods and replace as necessary.

4 Logix 3200/Q Positioner Overview

The Logix 3200/Q digital positioner is a two-wire 4-20 mA input digital valve positioner. The positioner is configurable through the local user interface. The Logix 3200/Q utilizes the HART protocol to allow two-way remote communications with the positioner. The Logix 3200/Q positioner can control both double- and single-acting actuators with linear or rotary mountings. The positioner is completely powered by the 4-20 mA input signal. Start up current must be at least 3.6 mA without AO card or 3.85 mA with AO card.

4.1 Specifications

Table I: Electrical Specifications

Power Supply	Two-wire, 4-20 mA 10.0 to 30.0 VDC
Compliance Voltage	10.0 VDC @ 20 mA
Effective Resistance	495 Ω @ 20 mA Typical Add 20 Ω when HART communication active
Communications	HART Protocol
Minimum Operating Current	3.6 mA without AO board 3.85 mA with AO board
Maximum Voltage	30.0 VDC

Table II: SoftTools Suite Software Specifications

Computer	Minimum Pentium processor running Windows 95, 98, NT, 2000, XP, 32 MB total memory (64 MB recommended), 30 MB available hard disk space, CD-ROM drive
Ports	1 minimum available with 8 maximum possible. (Can also communicate via PCMCIA and USB connections)
HART Modem	RS-232/PCMCIA card/USB
HART Filter	May be required in conjunction with some DCS hardware
HART MUX	MTL 4840/ELCON 2700

Table III: Environmental Conditions

Operating Temperature Range	Standard	-4° to 176°F (-20° to 80°C)
	Low	-40° to 176°F (-40° to 80°C)
Transport and Storage Temperature Range	-40° to 176°F (-40° to 80°C)	
Operating Humidity	0 - 100% non-condensing	

Note: The air supply must conform to ISA Standard ISA 7.0.01 (a dew point at least 18 degrees Fahrenheit below ambient temperature, particle size below five microns—one micron recommended—and oil content not to exceed one part per million).

Table IV: Physical Specifications

Housing Material	Cast, powder-painted aluminum, stainless steel
Soft Goods	Buna-N / Florosilicone
Weight	8.3 pounds (3.9 kg) aluminum 20.5 pounds (9.3 kg) stainless steel



Table V: Positioner Specifications

Deadband	<0.1% full scale
Repeatability	<0.05% full scale
Linearity	<0.5% (rotary), <0.8%, (sliding stem) full scale
Air Consumption	<0.3 SCFM (0.5 Nm ³ /hr) @ 60 psi (4 barg)

Table VI: 4 to 20 mA Analog Output Specifications

Potential Range of Rotation	40° - 95°
Power Supply Range	12.5 to 40 VDC, (24 VDC typical)
Maximum Load Resistance (ohms)	(Supply voltage - 12.5) / 0.02
Current Signal Output	4-20 mA
Linearity	1.0% F.S.
Repeatability	0.25% F.S.
Hysteresis	1.0% F.S.
Operating Temperature	-40° to 176°F, -40° to 80°C

Table VII: Hazardous Area Certifications

FM/CSA		
Intrinsically Safe		Explosion Proof
Class I, Div 1, Groups A, B, C, D Class II, Div 1, Groups E, F, G (See Figure 1 for installation requirements.)		Class I, Div 1, Groups A, B, C, D Class II, Div 1, Groups E, F, G
CENELEC		
Intrinsically Safe		II 1G EEx ia IIC T4, T5 T4 Ta = -40°C to 80°C T5 Ta = -40°C to 35°C
Flameproof		II 2 GD EEx d IIB + H ₂ T5, Ta = -40°C to 80°C
CE Compliant		

The Logix 3200/Q receives power from the two-wire, 4-20 mA input signal. However, since this positioner utilizes HART communications, two sources can be used for the command signal: Analog and Digital. In Analog source, the 4-20 mA signal is used for the command source. In Digital source, the level of the input 4-20 mA signal is ignored and a digital signal, sent via HART, is used as the command source. The command source can be accessed with SoftTools software, the HART 275/375 communicator, or other host software.

Whether in Analog or Digital Source, 0% is always defined as the valve closed position and 100% is always defined as the valve open position. In Analog Source, the 4-20 mA signal is converted to a percentage. During loop calibration, the signals corresponding to 0% and 100% are defined.

The input signal in percent passes through a characterization/limits modifier block. The positioner no longer uses CAMs or other mechanical means to characterize the output of the positioner. This function is done in software, which allows for in-the-field customer adjustment. The positioner has three basic modes: *Linear*, *Equal Percent (=%)* and *Custom* characterization. In *Linear* mode, the input signal is passed straight through to the control algorithm in a 1:1 transfer. In *Equal Percent (=%)* mode, the input signal is mapped to

4.2 Positioner Operation

The Logix 3200/Q positioner is an electric feedback instrument. Figure 1 shows a Logix 3200/Q positioner installed on a double-acting linear actuator for air-to-open action.

Figure 1: Logix 3200/Q Digital Positioner Schematic (air-to-open configuration)

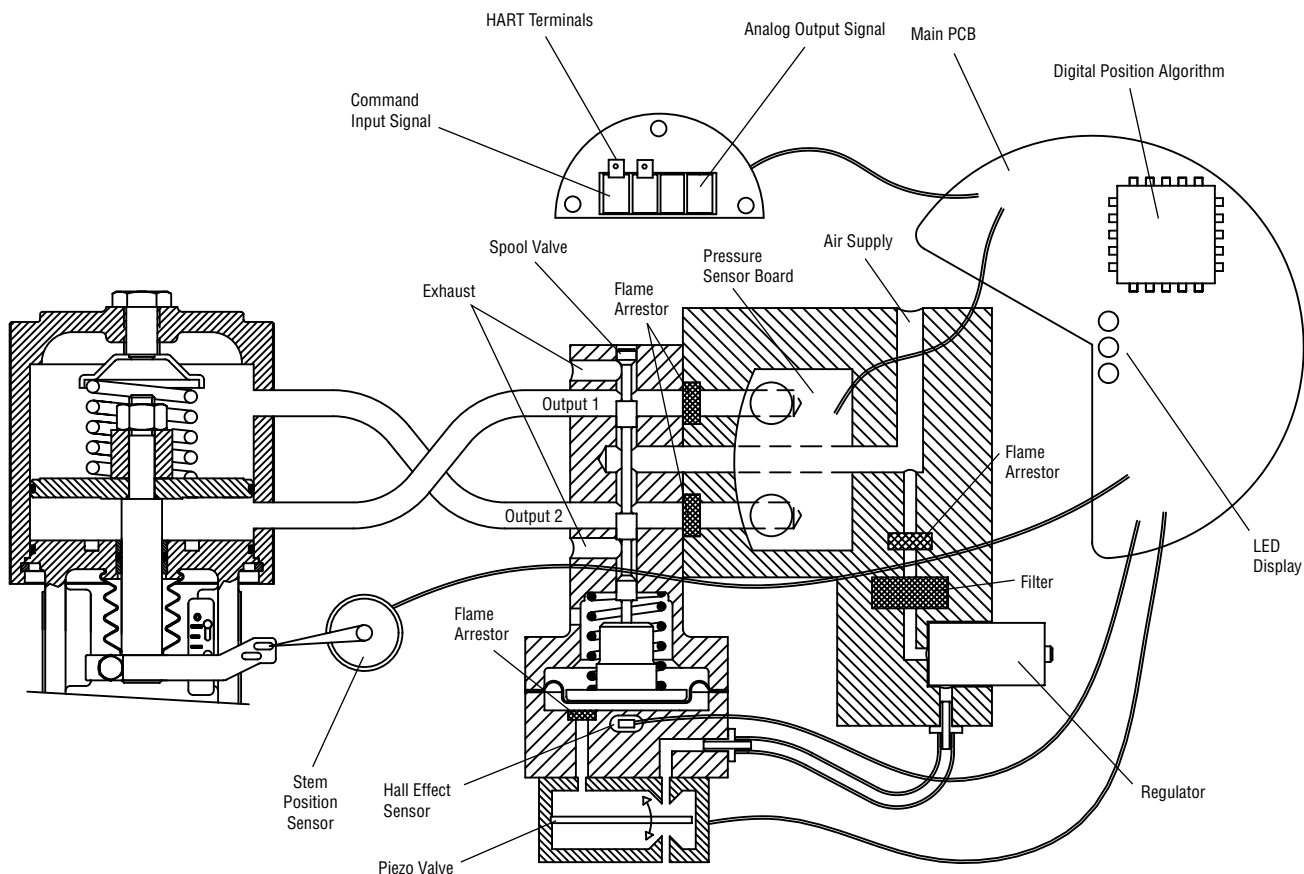
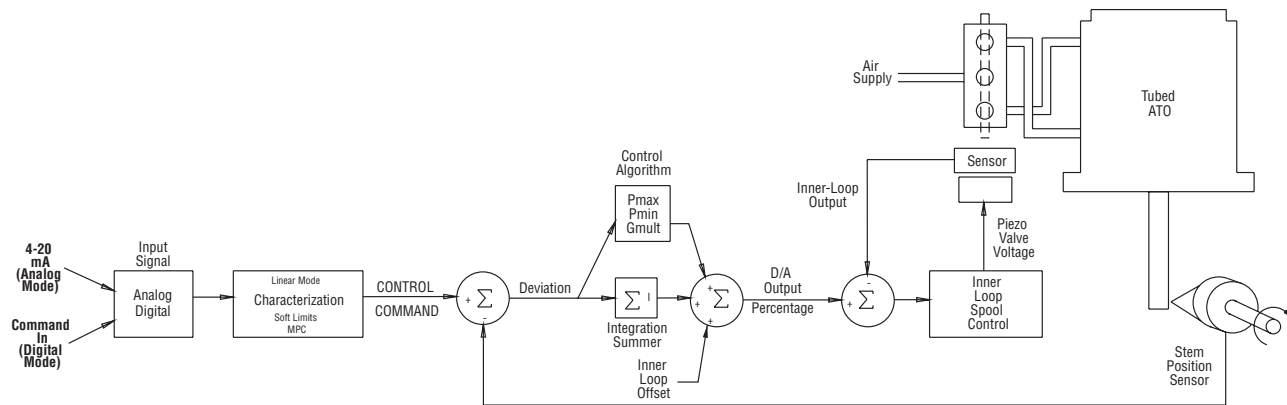

Figure 2: System Positioning Algorithm



a standard 30:1 rangeability =% curve. If *Custom* characterization is enabled, the input signal is mapped to either a default =% output curve or a custom, user-defined 21-point output curve. The custom user-defined 21-point output curve is defined using a handheld or PC software. In addition, two user-defined features, *Soft Limits* and *MPC* (Minimum Position Cutoff), may affect the final input signal. The actual command being used to position the stem, after any characterization or user limits have been evaluated, is called the *Control Command*.

The Logix 3200/Q uses a two-stage, stem-positioning algorithm. The two stages consist of an inner-loop, spool control and an outer-loop, stem position control. Referring again to Figure 1, a stem position sensor provides a measurement of the stem movement. The *Control Command* is compared against the *Stem Position*. If any deviation exists, the control algorithm sends a signal to the inner-loop control to move the spool up or down, depending upon the deviation. The inner-loop then quickly adjusts the spool position. The actuator pressures change and the stem begins to move. The stem movement reduces the deviation between *Control Command* and *Stem Position*. This process continues until the deviation goes to zero.

The inner-loop controls the position of the spool valve by means of a driver module. The driver module consists of a temperature-compensated hall effect sensor and a piezo valve pressure modulator. The piezo valve pressure modulator controls the air pressure under a diaphragm by means of a piezo beam bender. The piezo beam deflects in response to an applied voltage from the inner-loop electronics. As the voltage to the piezo valve increases, the piezo beam bends, closing off against a nozzle causing the pressure under the diaphragm to increase. As the pressure under the diaphragm increases or decreases, the spool valve moves up or down respectively. The hall effect sensor transmits the position of the spool back to the inner-loop electronics for control purposes.

4.3 Detailed Sequence of Positioner Operations

A more detailed example explains the control function. Assume the unit is configured as follows:

- Unit is in *Analog command source*.
- *Custom* characterization is disabled (therefore characterization is *Linear*).
- No soft limits enabled. No MPC set.
- Valve has zero deviation with a present input signal of 12 mA.
- Loop calibration: 4 mA = 0% command, 20 mA = 100% command.
- Actuator is tubed and positioner is configured air-to-open.

Given these conditions, 12 mA represents a *Command source* of 50 percent. *Custom characterization* is disabled so the *Command source* is passed 1:1 to the *Control Command*. Since zero deviation exists, the *Stem Position* is also at 50 percent. With the stem at the desired position, the spool valve will be at a middle position that balances the pressures above and below the piston in the actuator. This is commonly called the *null* or *balanced* spool position.

Assume the input signal changes from 12 mA to 16 mA. The positioner sees this as a *Command source* of 75 percent. With *Linear characterization*, the *Control Command* becomes 75 percent. Deviation is the difference between *Control Command* and *Stem Position*: Deviation = 75% - 50% = +25%, where 50 percent is the present stem position. With this positive deviation, the control algorithm sends a signal to move the spool up from its present position. As the spool moves up, the supply air is applied to the bottom of the actuator and air is exhausted from the top of the actuator. This new pressure differential causes the stem to start moving towards the desired position of 75 percent. As the stem moves, the *Deviation* begins to decrease. The control algorithm begins to reduce the spool opening.

Figure 3: Linear Mark One Control Valve Mounting

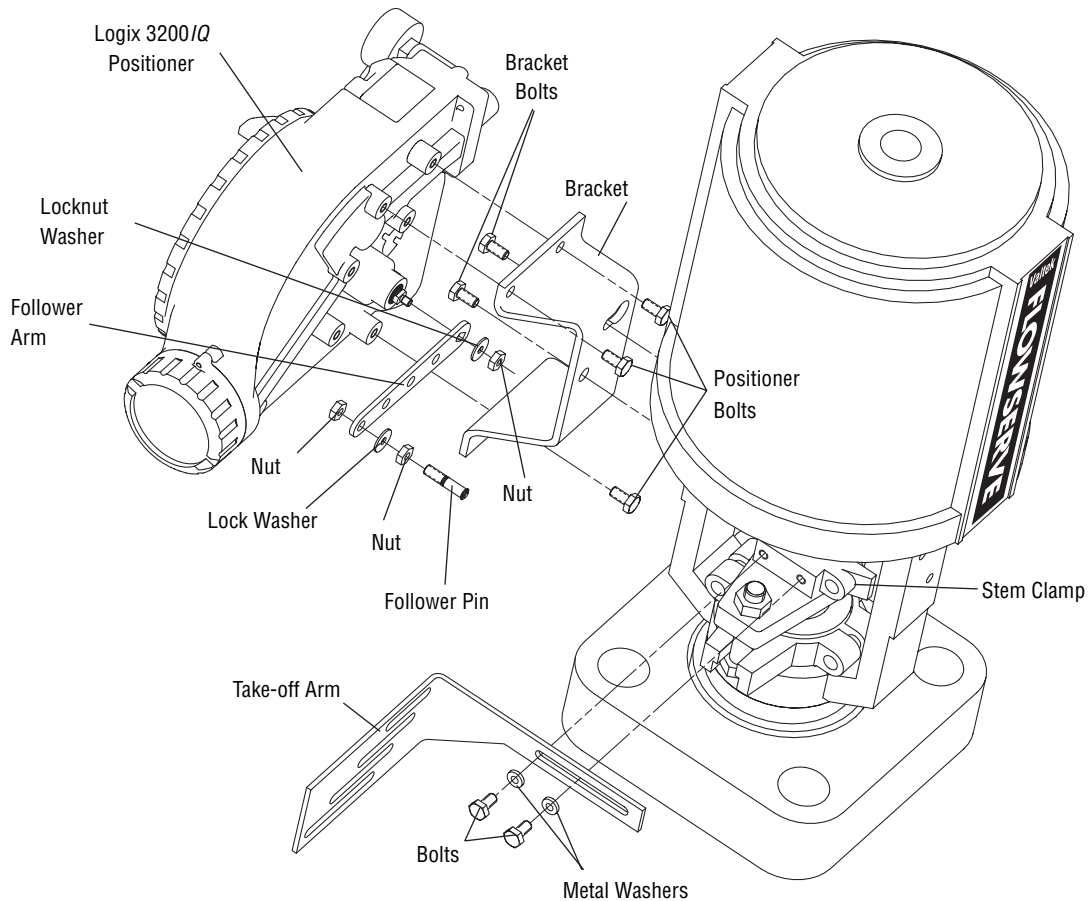

This process continues until the *Deviation* goes to zero. At this point, the spool will be back in its null or balanced position. Stem movement will stop and the desired stem position is now achieved.

One important parameter has not been discussed to this point: Inner loop offset. Referring to Figure 2, a number called *Inner loop offset* is added to the output of the control algorithm. In order for the spool to remain in its null or balanced position, the control algorithm must output a non-zero spool command. This is the purpose of the *Inner loop offset*. The value of this number is equivalent to the signal that must be sent to the spool position control to bring it to a null position with zero deviation. This parameter is important for proper control and is optimized and set automatically during stroke calibration.

5 Mounting and Installation

5.1 Mounting to Valtek Linear Mark One Valves

To mount a Logix 3200/Q positioner to a Valtek linear Mark One valve, refer to Figure 3 and proceed as outlined below. The following tools are required:

- $\frac{9}{16}$ " open-end wrench (or $\frac{1}{2}$ " for spud sizes 2.88 and smaller)
- $\frac{7}{16}$ " box wrench
- $\frac{3}{8}$ " open-end wrench

1. Remove washer and nut from follower pin assembly. Insert pin into the appropriate hole in follower arm, based on stroke length. The stroke lengths are stamped next to their corresponding holes in the follower arms. Make sure the unthreaded end of the pin is on the stamped side of the arm. Reinstall lock washer and tighten nut to complete follower arm assembly.
2. Slide the double-D slot in the follower arm assembly over the flats on the position feedback shaft in the back of the positioner.

- Make sure the arm is pointing toward the customer interface side of the positioner. Slide lock washer over the threads on the shaft and tighten down the nut.
3. Align the bracket with the three outer mounting holes on the positioner. Fasten with 1/4" bolts.
 4. Screw one mounting bolt into the hole on the yoke mounting pad nearest the cylinder. Stop when the bolt is approximately 3/16" from being flush with mounting pad.
 5. Slip the large end of the teardrop shaped mounting hole in the back of the positioner/bracket assembly over the mounting bolt. Slide the small end of the teardrop under the mounting bolt and align the lower mounting hole.
 6. Insert the lower mounting bolt and tighten the bolting.
 7. Position the take-off arm mounting slot against the stem clamp mounting pad. Apply Loctite 222 to the take-off arm bolting and insert through washers into stem clamp. Leave bolts loose.
 8. Slide the appropriate pin slot of the take-off arm, based on stroke length, over the follower arm pin. The appropriate stroke lengths are stamped by each pin slot.
 9. Center the take-off arm on the rolling sleeve of the follower pin.
 10. Align the take-off arm with the top plane of the stem clamp and tighten bolting. Torque to 120 in-lb.
- NOTE:** If mounted properly, the follower arm should be horizontal when the valve is at 50% stroke and should move approximately ±30° from horizontal over the full stroke of the valve. If mounted incorrectly, a stroke calibration error will occur and the indicator lights will blink a YRYR or YRRY code indicating the position sensor has gone out of range on one end of travel. Reposition the feedback linkage or rotate the position sensor to correct the error.

Figure 4: Standard Rotary Mounting

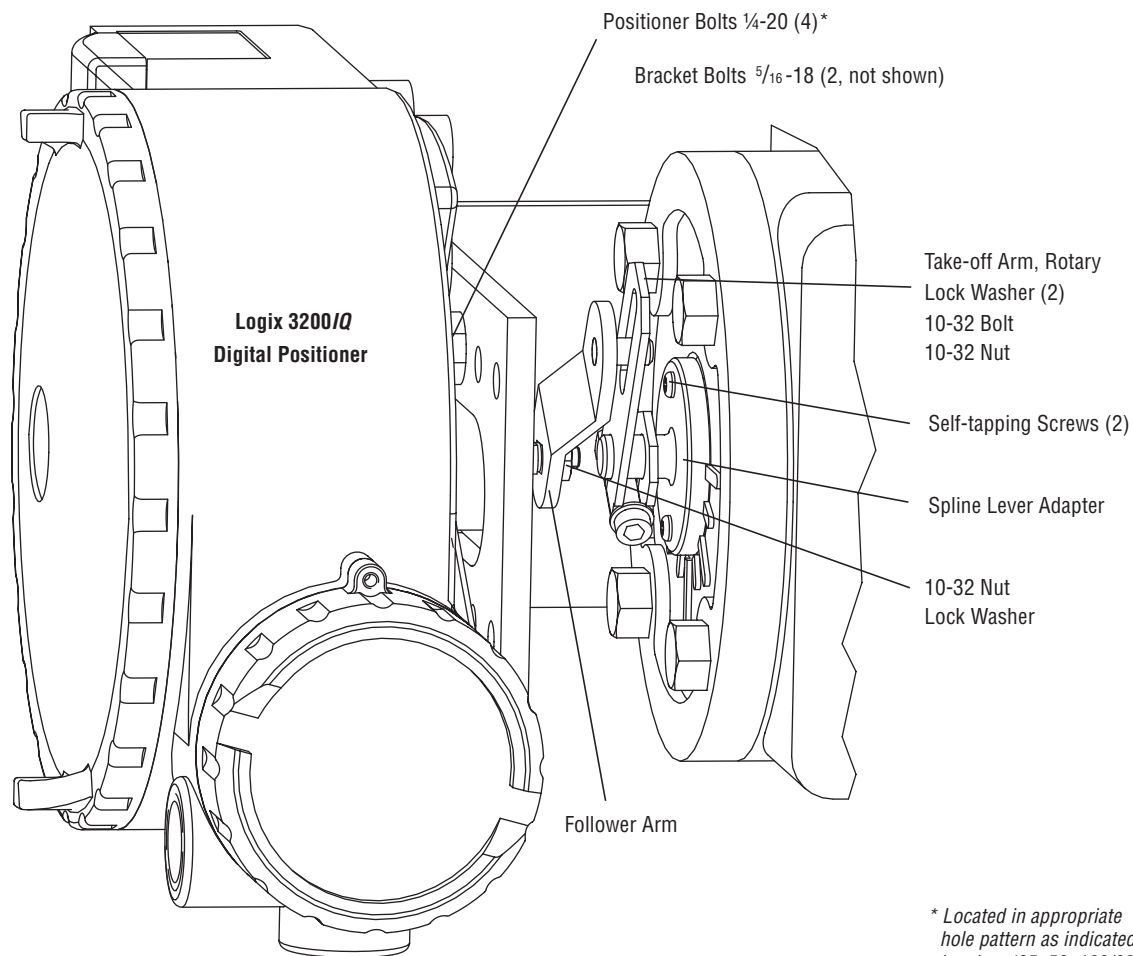

* Located in appropriate hole pattern as indicated on bracket. (25, 50, 100/200)

5.2 Mounting to Standard Valtek Rotary Valves (See Figure 4)

The standard rotary mounting applies to Valtek valve/actuator assemblies that do not have mounted volume tanks or handwheels. The standard mounting uses a linkage directly coupled to the valve shaft. This linkage has been designed to allow for minimal misalignment between the positioner and the actuator. The tools required for the following procedure are:

- 5/32" Allen wrench
- 1/2" open-end wrench
- 7/16" open-end wrench
- 3/8" socket with extension
- 3/16" nutdriver

1. Fasten the spline lever adapter to the splined lever using two 6 x 1/2" self-tapping screws.
2. Slide the take-off arm assembly onto the spline lever adapter shaft. Insert the screw with star washer through the take-off arm and add the second star washer and nut. Tighten nut with socket so arm is lightly snug on the shaft but still able to rotate. This will be tightened after linkage is correctly oriented.
3. Attach follower arm to positioner feedback shaft using the star washer and 10-32 nut.

NOTE: The arm will point up when feedback shaft is in the free position.

4. Using four 1/4-20 x 1/2" bolts, fasten positioner to universal bracket using appropriate hole pattern (stamped on bracket).

Figure 5: Optional Rotary Mounting

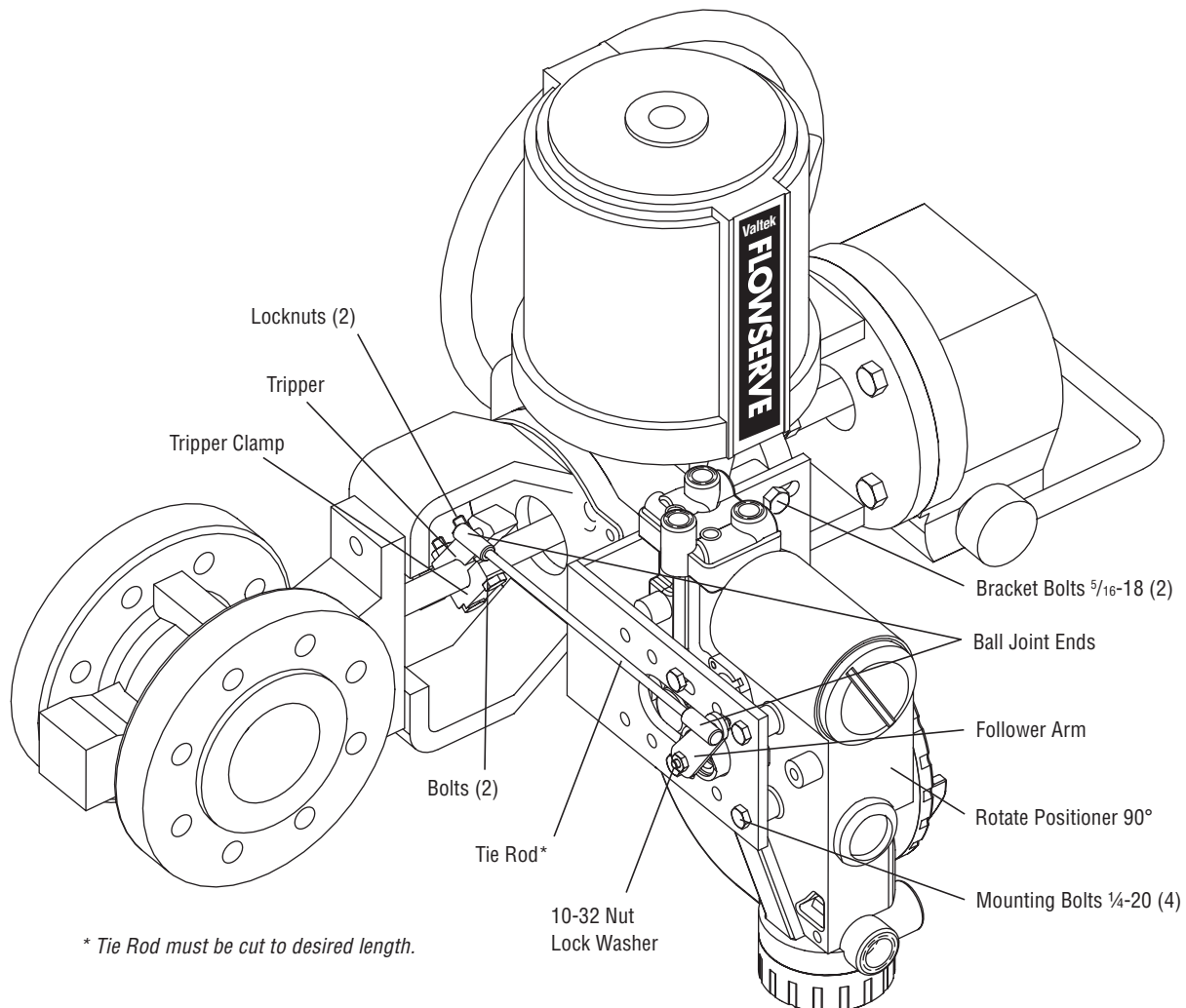

5. Using a 1/2" end wrench and two 5/16-18 x 1/2" bolts, attach bracket to actuator transfer case pad. Leave these bolts slightly loose until final adjustments are made.
6. Rotate take-off arm so the follower pin will slide into the slot on the take-off arm. Adjust the bracket position as needed noting the engagement of the follower pin and the take-off arm slot. The pin should extend approximately 1/16" past the take-off arm. When properly adjusted, securely tighten the bracketing bolts.

Orienting the Take-off Arm for Final Lock Down

1. Tube the Logix 3200/Q positioner to the actuator according to the instructions given in Section 5.4, "Tubing Positioner to Actuator."
2. **With supply pressure off**, rotate the follower arm in the same direction the shaft would rotate upon a loss of supply pressure. When the mechanical stop of the follower arm (positioner) is reached, rotate back approximately 15 degrees.
3. Hold the take-off arm in place; tighten the screw of the take-off arm.

NOTE: The take-off arm should be snug enough to hold the follower arm in place but allow movement when pushed.

4. Connect regulated air supply to appropriate port in manifold.
5. Remove main cover and locate DIP switches and QUICK-CAL button.
6. Refer to sticker on main board cover and set DIP switches accordingly. (A more detailed explanation of the DIP switch settings is given in Section 7, "Startup.")
7. Press the QUICK-CAL button for three to four seconds or until the positioner begins to move. The positioner will now perform a stroke calibration.
8. If the calibration was successful the green LED will blink GGGG or GGGY and the valve will be in control mode. Continue with step 9. If calibration failed, as indicated by a YRYR or YRRY blink code, the A/D feedback values were exceeded and the arm must be adjusted away from the positioners limits. Return to step 2 and rotate the arm back approximately 10 degrees.

NOTE: Remember to remove the air supply before re-adjusting take-off arm.

9. Tighten the nut on the take-off arm. The socket head screw of the take-off arm must be tight, about 40 in-lb.

NOTE: If the take-off arm slips, the positioner must be recalibrated.

⚠ WARNING: Failure to follow this procedure will result in positioner and/or linkage damage. Check air-action and stroke carefully before lockdown of take-off arm to spline lever adapter.

5.3 Optional Valtek Rotary Mounting Procedure (See Figure 5)

The optional rotary mounting applies to Valtek valve/actuator assemblies that are equipped with mounted volume tanks or handwheels. The optional mounting uses a four-bar linkage coupled to the valve shaft. The following tools are required:

- 3/8" open-end wrench
- 7/16" open-end wrench
- 1/2" open-end wrench

1. Using a 1/2" open-end wrench and two 5/16-18 x 1/2" bolts, attach bracket to actuator transfer case pads. Leave bracket loose to allow for adjustment.
2. Using four 1/4-20 x 1/2" bolts and a 7/16" open-end wrench, fasten positioner to universal bracket, using the four-hole pattern that locates the positioner the farthest from the valve. Rotate positioner 90 degrees from normal so gauges are facing upward.
3. Attach follower arm to positioner feedback shaft, using the star washer and 10-32 nut.
4. Attach tripper and tripper clamp to valve shaft using two 1/4-20 bolts and two 1/4-20 locknuts. Leave tripper loose on shaft until final adjustment.
5. Thread ball joint linkage end to tripper and tighten (thread locking compound such as Loctite is recommended to prevent back threading). Adjust the length of tie rod so follower arm and tripper rotate parallel to each other (the rod must be cut to the desired length). Connect the other ball joint end to follower arm using a star washer and a 10-32 nut.
6. Tighten bracket and tripper bolting.
7. Check for proper operation, note direction of rotation.

⚠ WARNING: If rotating in wrong direction, serious damage will occur to the positioner and/or linkage. Check air action and stroke direction carefully before initiating operation.

5.4 Tubing Positioner to Actuator

The Logix 3200/Q digital positioner is insensitive to supply pressure changes and can handle supply pressures from 30 to 150 psig. A supply regulator is recommended if the customer will be using the diagnostic features of the Logix 3200/Q but is not required. In applications where the supply pressure is higher than the maximum actuator pressure rating a supply regulator is required to lower the pressure to the actuator's maximum rating (not to be confused with operating range). An air filter is highly recommended for all applications where dirty air is a possibility.

NOTE: The air supply must conform to ISA Standard ISA 7.0.01 (a dew point at least 18°F below ambient temperature, particle size below five microns—one micron recommended—and oil content not to exceed one part per million).

Air-to-open and air-to-close are determined by the actuator tubing, not the software. When air action selection is made during configuration, that selection tells the control which way the actuator has been tubed. The top output port is called *Output 1*. It should be tubed to the side of the actuator that must receive air to begin the correct action on increasing signal. Verify that tubing is correct prior to a stroke calibration. Proper tubing orientation is critical for the positioner to function correctly and have the proper failure mode. Refer to Figure 1 and follow the instructions below:

Linear Double-acting Actuators

For a linear air-to-open actuator, the Output 1 port of the positioner manifold is tubed to the bottom side of the actuator. The Output 2 port of the positioner manifold is tubed to the top side of the actuator. For a linear air-to-close actuator the above configuration is reversed.

Rotary Double-acting Actuators

For a rotary actuator, the Output 1 port of the positioner manifold is tubed to the bottom side of the actuator. The Output 2 port of the positioner manifold is tubed to the top side of the actuator. This tubing convention is followed regardless of air action. On rotary actuators, the transfer case orientation determines the air action.

Single-acting Actuators

For single-acting actuators, the Output 1 port is always tubed to the pneumatic side of the actuator regardless of air action. The Output 2 port must be plugged.

6 Wiring and Grounding Guidelines (See Figure 6)

WARNING: This product has electrical conduit connections in either thread sizes ½" NPT or M20 which appear identical but are not interchangeable. Housings with M20 threads are stamped with the letters M20 above the conduit opening. Forcing dissimilar threads together will damage equipment, cause personal injury and void hazardous location certifications. Conduit fittings must match equipment housing threads before installation. If threads do not match, obtain suitable adapters or contact a Flowserve representative.

Figure 6: Field Termination

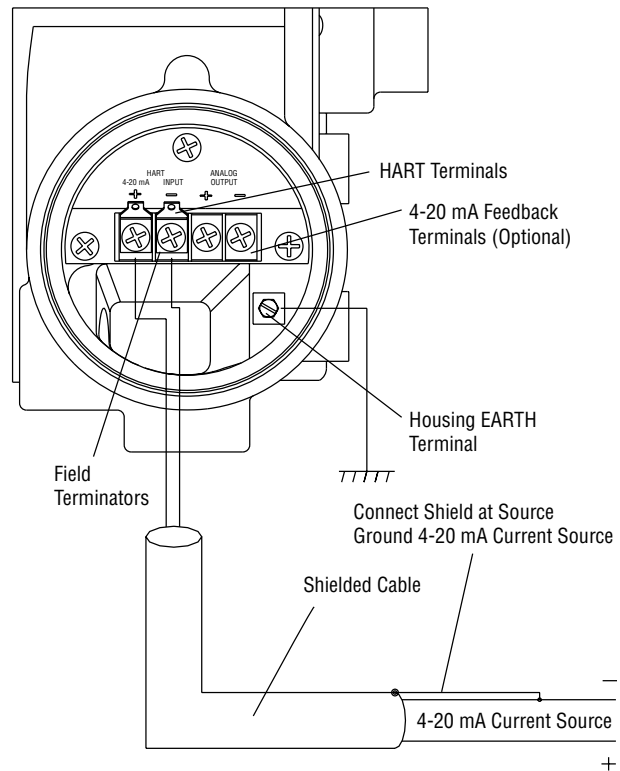

6.1 4-20 mA Command Input Wiring

Verify polarity when making field termination connection. The Logix 3200 is reverse polarity protected. Wire 4-20 mA current source to the input terminal labeled 4-20 mA Input on the user interface board (see Figure 6). Never connect a voltage source directly across the Logix 3200/Q terminals. The current must always be limited for 4-20 mA operation. Minimum operating current is 3.6 mA.

The input loop current signal to the Logix 3200/Q digital positioner should be in shielded cable. Shields must be tied to a ground at only one end of the cable to provide a place for environmental electrical noise to be removed from the cable. In general, shield wire should be connected at the source.

NOTE: The Logix 3200/Q positioner carries an intrinsically safe barrier rating of 100 mA. Input currents should not exceed 100 mA.

6.2 Grounding Screw

The green grounding screw, located inside the termination cap, should be used to provide the unit with an adequate and reliable earth ground reference. This ground should be tied to the same ground as the electrical conduit. Additionally, the electrical conduit should be earth grounded at both ends of its run.

WARNING: The green grounding screw must not be used to terminate signal shield wires.

6.3 Compliance Voltage (See Figure 7)

Output compliance voltage refers to the voltage limit that can be provided by the current source. A current loop system consists of the current source, wiring resistance, barrier resistance (if present), and the Logix 3200/Q positioner impedance. The Logix 3200/Q digital positioner requires that the current loop system allows for a 10.0 VDC drop across the positioner at maximum loop current. The 10.0 VDC drop across the Logix 3200/Q positioner terminals is generated by the positioner from the 4-20 mA loop current input.

Figure 7: Compliance Voltage

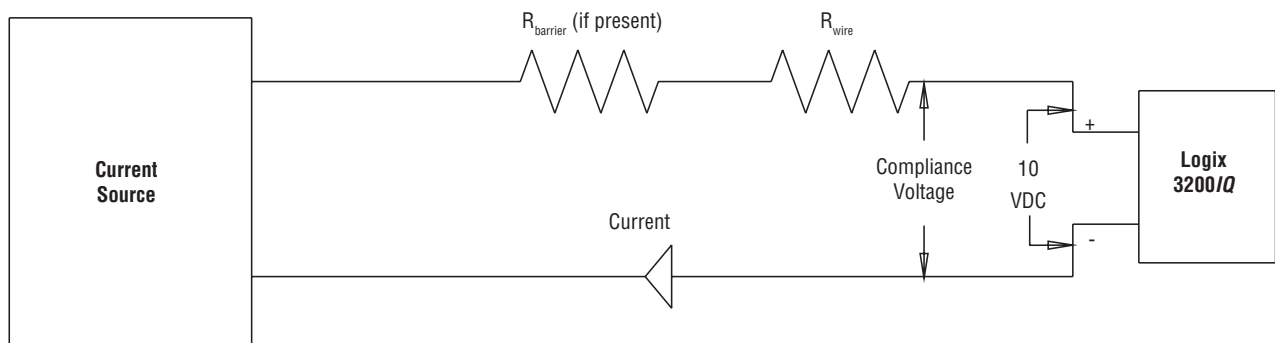

The actual voltage at the terminals varies from 9.8 to 10.0 VDC depending on the current mA signal, HART communications, and ambient temperature.

WARNING: Never connect a voltage source directly across the positioner terminals. This could cause permanent circuit board damage.

Determine if the loop will support the Logix 3200/Q digital positioner by performing the following calculation.

$$\text{Voltage} = \text{Compliance Voltage (@Current}_{\text{max}}) - \text{Current}_{\text{max}} \cdot (R_{\text{barrier}} + R_{\text{wire}}) \quad \text{Equation 1}$$

The calculated voltage must be greater than 10 VDC in order to safely support the Logix 3200/Q digital positioner.

Example:

DCS Compliance Voltage = 19 VDC

$R_{\text{barrier}} = 300 \Omega$

$R_{\text{wire}} = 25 \Omega$

$\text{Current}_{\text{max}} = 20 \text{ mA}$

$\text{Voltage} = 19 \text{ VDC} - 0.020 \text{ A} \cdot (300 \Omega + 25 \Omega) = 12.5 \text{ VDC}$

The voltage 12.5 VDC is greater than the required 10.0 VDC; therefore, this system will support the Logix 3200/Q digital positioner. The Logix 3200/Q positioner has a worst case input resistance equivalent to 500 Ω at a 20 mA input current.

6.4 Cable Requirements

The Logix 3200/Q digital positioner utilizes the HART Communication protocol. This communication signal is superimposed on the 4-20 mA current signal. The two frequencies used by the HART protocol are 1200 Hz and 2200 Hz. In order to prevent

distortion of the HART communication signal, cable capacitance and cable length restrictions must be calculated. The cable length must be limited if the capacitance is too high. Selecting a cable with lower capacitance/foot rating will allow longer cable runs. In addition to the cable capacitance, the network resistance also affects the allowable cable length.

In order to calculate the maximum network capacitance, use the following formula:

$$C_{\text{network}} (\mu\text{F}) \leq \left[\frac{65}{(R_{\text{barrier}} + R_{\text{wire}} + 390)} \right] - 0.0032 \quad \text{Equation 2}$$

Example: $R_{\text{barrier}} = 300 \Omega$
 $R_{\text{wire}} = 50 \Omega$
 $C_{\text{cable}} = \frac{22 \text{ pF}}{\text{foot}} = \frac{0.000022 \mu\text{F}}{\text{foot}}$

$$\left[\frac{65}{(300 + 50 + 390)} \right] - 0.0032 = 0.08 \mu\text{F} = C_{\text{max network}} (\mu\text{f})$$

$$\text{Maximum Cable Length} = \frac{C_{\text{max network}} (\mu\text{F})}{C_{\text{cable}}}$$

$$\text{Maximum Cable Length} = \frac{0.08 \mu\text{F}}{0.000022 \mu\text{F/foot}} = 3636 \text{ ft.}$$

To control cable resistance, 24 AWG cable should be used for runs less than 5000 feet. For cable runs longer than 5000 feet, 20 AWG cable should be used.

6.5 Intrinsically Safe Barriers

When selecting an intrinsically safe barrier, make sure the barrier is HART compatible. Although the barrier will pass the loop current and allow normal positioner control, if not compatible, it may prevent HART communication.

7 Startup

7.1 Logix 3200/Q Local Interface Operation

The Logix 3200/Q local user interface (Figure 8) allows the user to configure the basic operation of the positioner, tune the response, and calibrate the positioner without additional tools or configurators. The Local interface consists of a QUICK-CAL button for automatic zero and span setting, along with two jog buttons (↑ and ↓) for spanning valve/actuators with no fixed internal stop in the open position. There is also a DIP switch block containing eight switches. Seven of the switches are for basic configuration settings and one is for calibration options. There is also a rotary selector switch for adjusting the positioner gain settings. For indication of the operational status or alarm conditions there are also three LEDs on the local user interface.

Figure 8: Local User Interface

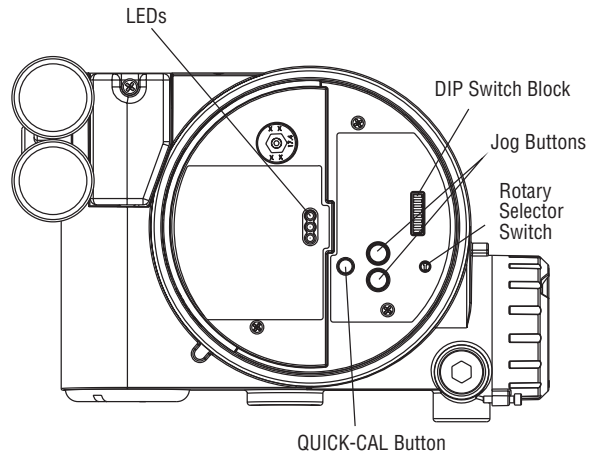

7.2 Initial DIP Switch Settings

Before placing the unit in service, set the DIP switches in the Configuration and Cal boxes to the desired control options. A detailed description of each DIP switch setting follows.

NOTE: The Logix 3200/Q positioner reads the DIP switch settings each time the QUICK-CAL button is pressed. If a HART handheld or Flowserve PC software is used to configure and then calibrate the positioner, the DIP switches are not read. The auto-tune adjustment switch labeled “GAIN” is always live and can be adjusted at any time.

7.3 Description of Configuration DIP Switch Settings

The first seven DIP switches are for basic configuration. The function of each switch is described below.

Air Action

This must be set to match the configuration of the valve/actuator mechanical tubing connection and spring location since these determine the air action of the system.

ATO (air-to-open) Selecting ATO if increasing output pressure from the positioner is tubed so it will cause the valve to open.

ATC (air-to-close) Selecting ATC if increasing output pressure from the positioner is tubed so it will cause the valve to close.

Signal at Closed

Normally this will be set to 4 mA for an Air-to-open actuator, and 20 mA for an Air-to-close actuator configuration.

4 mA Selecting 4 mA will make the valve fully closed when the signal is 4 mA and fully open when the signal is 20 mA.

20 mA Selecting 20 mA will make the valve fully closed when the signal is 20 mA and fully open when the signal is 4 mA.

Pos. Characterization

Linear Select *Linear* if the actuator position should be directly proportional to the input signal.

Optional Select *Optional* if another characteristic is desired, which is set in conjunction with the next switch, labeled *Optional Pos. Char.*

Optional Pos. Characterization

If the Pos. Characterization switch is set to optional then this switch is active with the following options:

=% The =% option will characterize the actuator response to the input signal based on a standard 30:1 equal percent range-ability curve.

Custom If *Custom* is selected, the positioner will be characterized to a custom table that must be set-up using a properly configured HART 275/375 handheld or other host software. *Custom* characterization can be thought of as a “soft CAM.” The user can define a characterization curve using 21 points. The control will linearly interpolate between points. Points do not have to be equally spaced in order to allow more definition at critical curve areas. The default values will linearize the output of a valve with an inherent =% characteristic (e.g. ball valves.)

Figure 9: Default Custom Characterization

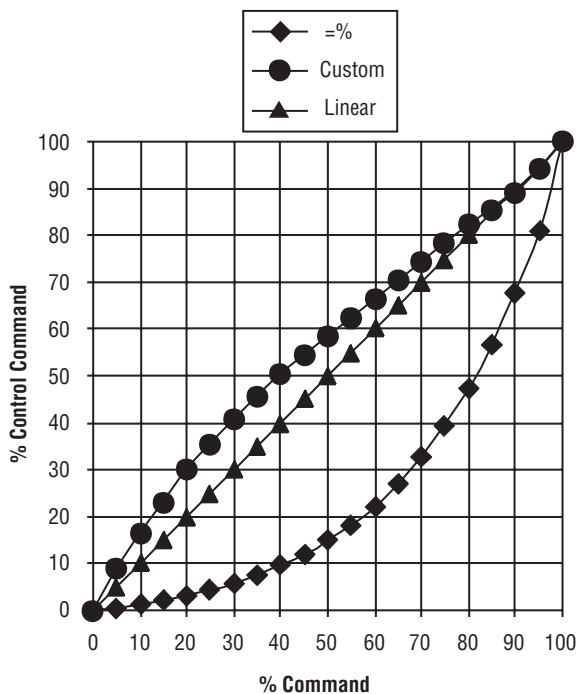

Table VIII: Characteristic Curve Data

% Command	% Control Command		
	=%	Linear	Custom
0	0	0	0
5	0.62	5	8.66
10	1.35	10	16.24
15	2.22	15	23.17
20	3.25	20	30.11
25	4.47	25	35.31
30	5.91	30	40.51
35	7.63	35	45.42
40	9.66	40	50.34
45	12.07	45	54.40
50	14.92	50	58.47
55	18.31	55	62.39
60	22.32	60	66.31
65	27.08	65	70.27
70	32.71	70	74.23
75	39.40	75	78.17
80	47.32	80	82.11
85	56.71	85	85.50
90	67.84	90	88.89
95	81.03	95	94.45
100	100.00	100	100.00

Auto Tune

This switch controls whether the positioner will auto tune itself every time the QUICK-CAL button is pressed or use preset tuning parameters.

On *On* enables an auto tune feature that will automatically determine the positioner gain settings based on the current position of the adjustable GAIN switch setting and response parameters measured during the last QUICK-CAL. The GAIN switch is live, meaning the settings can be adjusted at any time by changing the rotary switch position. (Note that there is a small black arrow indicating the selection. The slot in the switch is NOT the indicator.)

Figure 10: Adjustable GAIN Switch



If the adjustable GAIN selector switch is set to “E” with the auto tune switch on, a Flowserve standard response tuning set will be calculated and used based on response parameters measured during the last QUICK-CAL.

If the adjustable GAIN selector switch is set to “D”, “C”, “B”, or “A” with the auto tune switch on, progressively lower gain settings will be used based on response parameters measured during the last QUICK-CAL.

If the adjustable GAIN selector switch is set to “F”, “G”, or “H” with the auto tune switch on, progressively higher gain settings will be calculated and used based on response parameters measured during the last QUICK-CAL.

Off *Off* forces the positioner to use one of the factory preset tuning sets determined by the adjustable GAIN selector switch. Settings “A” through “H” are progressively higher gain predefined tuning sets. The GAIN selector switch is live and can be adjusted at any time to modify the tuning parameters.

NOTE: “E” is the default adjustable GAIN selector switch setting for all actuator sizes. Raising or lowering the gain setting is a function of the positioner/valve response to the control signal, and is not actuator size dependent.

Configuration Switches

Enabled By selecting *Enabled*, the Logix 3200/IQ will read all of the configuration switches each time a QUICK-CAL is performed to determine the configuration.

Disabled Selecting *Disabled* retains the last configuration in memory (from the last successful calibration) before the switch

was set to Disabled. With this setting a QUICK-CAL only zeros and spans the positioner.

Stability Switch

This switch adjusts the position control algorithm of the positioner for use with low-friction control valves or high-friction automated valves.

Low-Friction Valves Placing the switch to the left optimizes the response for low-friction, high-performance control valves. This setting provides for optimum response times when used with most low-friction control valves.

High-Friction Valves Placing the switch to the right optimizes the response for valves and actuators with high friction levels. This setting slightly slows the response and will normally stop limit cycling that can occur on high-friction valves.

7.4 Description of Cal DIP Switch Settings

The eighth DIP switch selects between two calibration options. The function of the Cal DIP switch is described below.

Auto Select *Auto* if the valve/actuator assembly has an internal stop in the open position. In *Auto* mode the positioner will fully *close* the valve and register the 0% position and then *open* the valve to the stop to register the 100% position when performing a self-calibration. See detailed instructions in the next section on how to perform an auto positioner calibration.

Jog Select *Jog* if the valve/actuator assembly has no physical calibration stop in the open position. In the *Jog* mode the positioner will fully close the valve for the 0% position and then wait for the user to set the open position using the Jog buttons labeled with the up and down arrows. See the detailed instructions in the next section on how to perform a manual calibration using the Jog buttons.

⚠ WARNING: During the QUICK-CAL operation the valve may stroke unexpectedly. Notify proper personnel that the valve will stroke, and make sure the valve is properly isolated.

7.5 QUICK-CAL Operation

The QUICK-CAL button is used to locally initiate a calibration of the positioner. Pressing and holding the QUICK-CAL button for approximately three seconds will initiate the calibration. If the Config-Switches option is enabled, the settings of all the configuration switches are read and the operation of the positioner adjusted accordingly. A QUICK-CAL can be aborted at any time by briefly

pressing the QUICK-CAL button and the previous settings will be retained.

If the Quick Calibration switch (be careful not to confuse this with the QUICK-CAL button) is set to Auto and the valve/actuator assembly has the necessary internal stops the calibration will complete automatically. While the calibration is in progress you will notice a series of different lights flashing indicating the calibration progress. When the lights return to a sequence that starts with a green light the calibration is complete. An explanation of the various light sequences follows. The initial calibration of extremely large or small actuators may require several calibration attempts. The positioner adapts to the actuator performance and begins each calibration where the last attempt ended. On an initial installation it is recommended that after the first successful calibration that one more calibration be completed for optimum performance.

⚠ WARNING: When operating using QUICK-CAL or local control, the valve will not respond to external commands. Notify proper personnel that the valve will not respond to remote command changes, and make sure the valve is properly isolated.

7.6 Manual Jog Calibration Operation

If the Quick Calibration switch is set to Jog, the calibration will initially close the valve then cause a small jump in the valve position. The jog calibration process will only allow the user to manually set the span; zero position is automatically always set at the seat. If an elevated zero is needed a handheld or other PC-based configuration software is required. When performing a jog calibration, the LEDs will flash in a sequence of Y-R-R-G (yellow-red-red-green) which indicates that the user must use the Jog buttons (↑ and ↓) to manually position the valve to approximately 100%. When the valve is approximately 100% open press both the Jog buttons (↑ and ↓) simultaneously to proceed to the next step. The valve will stroke and then wait while flashing the Y-R-R-G sequence again, allowing the user to adjust the valve position a second time to exactly 100% using the Jog buttons (↑ and ↓). When the stem is properly positioned press both the Jog buttons (↑ and ↓) simultaneously again to register the 100% position and proceed. No more user actions are required while the calibration process is completed. When the lights return to a sequence that starts with a green light the calibration is complete. An explanation of the various light sequences follows.

7.7 Local Control of Valve Position

Local control of valve position can be achieved from the user interface by holding down both Jog buttons and the QUICK-CAL button simultaneously for three seconds. While in this mode the LEDs will flash a YGRR (yellow-green-red-red) sequence. Use the two Jog buttons (↑ and ↓) to manually control the position of the valve. To exit the local control mode and return to normal operation, briefly press the QUICK-CAL button.

7.8 Factory Reset

To perform a factory reset, disconnect power, hold the QUICK-CAL button down, and reconnect power. Performing a factory reset will cause all of the internal variables, including calibration, to be reset to factory defaults. The positioner must be recalibrated after a factory reset. Tag names and other user configured limits, alarm settings, and valve information will also need to be restored.

⚠ WARNING: Performing a factory reset may result in the inability to operate the valve until reconfigured properly. Notify proper personnel that the valve may stroke, and make sure the valve is properly isolated.

7.9 Command Source Reset

Performing a command source reset will reset the command source to analog source if it has been inadvertently left in digital mode. This is done while a QUICK-CAL is in process by holding down both the Jog buttons (↑ and ↓) while briefly pressing the QUICK-CAL button. A new QUICK-CAL must be done after resetting.

7.10 Logix 3200/Q Status Condition

The blink codes used to convey the status of the Logix 3200/Q digital positioner are described in the table below. In general, any sequence starting with a green light flashing first is a normal operating mode and indicates that there are no internal problems. Any sequence starting with a yellow light flashing indicates that the unit is in a special calibration or test mode, or that there was a calibration problem. Any sequence starting with a red light flashing indicates that there is an operational problem with the unit.

Colors	Identifier	Indication and Resolution
G - - -		Any sequence starting with a green light flashing first is a normal operating mode and indicates that there are no internal problems.
GGGG	1	Normal operation Analog Command mode. No errors, alerts, or warnings.
GGGY	2	Tight shutoff (MPC) active The command is below the user-set limit for tight shutoff feature. This is a normal condition for a closed valve. The factory default setting is 1% command. To clear the condition use handheld or Flowserve-supplied software to reset the tight shutoff if the range is incorrect or adjust the command signal above the specified MPC value.
GGYG	3	Digital command mode The analog 4-20 mA input signal is ignored in this mode and a handheld or Flowserve-supplied software is needed to change the position command. (Note a command reset is provided to change the command back to analog control mode from the local interface if a PC or handheld configurator is not available.)
GGYR	4	Initializing This sequence should only be visible for three sequences when powering up the unit.
GGRG	5	Cycle limit exceeded (user-set) The cycle limit set by the user has been exceeded. To clear use handheld or Flowserve-supplied software to reset.
GGRY	6	Travel limit exceeded (user-set) The total accumulated travel limit set by the user has been exceeded. To clear use handheld or Flowserve-supplied software to reset.
GGYR	7	Lower soft stop reached (user-set) The unit is being commanded to exceed a user-defined lower position limit and the internal software is holding the position at the limit. The function is similar to a mechanical limit stop except it is not active if the unit is un-powered. To clear the condition use handheld or Flowserve-supplied software to reset the limit if more travel is needed or adjust the command signal back in the specified range.
GGRY	8	Upper soft stop reached (user-set) The unit is being commanded to exceed a user-defined upper position limit and the internal software is holding the position at the limit. The function is similar to a mechanical limit stop except it is not active if the unit is un-powered. To clear the condition use handheld or Flowserve-supplied software to reset the limit if more travel is needed or adjust the command signal back in the specified range.
GRRY	9	Lower position alert (user-set) The position has reached or is exceeding a user-defined lower position indicator similar to a limit switch indicator. To clear the condition use handheld or Flowserve-supplied software to reset the indicator if more travel is needed or adjust the command signal back in the specified range.
GRRY	10	Upper position alert (user-set) The position has reached or is exceeding a user-defined upper position indicator similar to a limit switch indicator. To clear the condition use handheld or Flowserve-supplied software to reset the indicator if more travel is needed or adjust the command signal back in the specified range.

Colors	Identifier	Indication and Resolution
Y - - -		Any sequence starting with a yellow light indicates that the unit is in a special calibration or test mode, or that there was a calibration problem.
YGYG	11	Signature test in progress This is a test initiated by Flowserve-supplied software that can only be cancelled by that software.
YYYG	12	Loop calibration in progress Calibration sequence controlled by a handheld or Flowserve-supplied software that can only be cancelled by that software.
YRGG	13	Stroke calibration in progress Calibration sequence started either using the local QUICK-CAL button or by a handheld or Flowserve-supplied software. It may be cancelled by briefly pushing the QUICK-CAL button.
YGRR	14	Local jog control mode The unit has been placed in a local override mode where the valve can only be stroked using the two local jog buttons. It may be cancelled by briefly pushing the QUICK-CAL button.
YYGR	15	Pressure calibration in progress Calibration sequence controlled by a handheld or Flowserve-supplied software that can only be cancelled by that software.
YYYY	16	Local user interface disabled PC software has been used to disable the local interface. If local control is desired then the local interface must be re-enabled from the remote software. This code is only present for a short time when the QUICK-CAL button is pressed.
YRRG	17	Waiting Adjust to full open position setting from User—only used during Jog calibration see explanation in Section 7.5, “QUICK-CAL,” for operation.
YRYG	18	Setting IL offset while calibrating An automatic step in the calibration process that is done with the valve at 50% position. This must be completed for proper calibration.
YRYR	19	No feedback motion while calibrating Indicates that there was no motion of the actuator based on the current stroke time configuration. Check linkages and air supply to make sure the system is properly connected. If the time out occurred because the actuator is very large then simply retry the QUICK-CAL and the positioner will automatically adjust for a larger actuator by doubling the time allowed for movement. This error may be cleared by briefly pushing the QUICK-CAL button, which will force the positioner to use the parameters from the last good calibration.
YRYY	20	Feedback 0% out of range Calibration error indicating that the position sensor was out of range during the calibration of the closed position. To correct the condition, adjust the positioner mounting, linkage or feedback potentiometer to move the position sensor back into range then restart the calibration. This error may be cleared by briefly pushing the QUICK-CAL button, which will force the positioner to use the parameters from the last good calibration.

Continued on page 19

Colors	Identifier	Indication and Resolution
YRRY	21	Feedback 100% out of range Calibration error indicating that the position sensor was out of range during the calibration of the open position. To correct the condition, adjust the positioner mounting, linkage or feedback potentiometer to move the position sensor back into range then restart the calibration. This error may be cleared by briefly pushing the QUICK-CAL button, which will force the positioner to use the parameters from the last good calibration.
YRRR	22	Feedback span too small The range of motion of the position feedback arm was too small for optimum performance. Check for loose linkages and/or adjust the feedback pin to a position closer to the follower arm pivot to create a larger angle of rotation and recalibrate. Briefly pushing the QUICK-CAL button acknowledges this condition and the positioner will operate using the current short stroke calibration if otherwise a good calibration.
YRGR	23	Feedback unstable while calibrating Check for loose linkages or loose positioner sensor. This error may be cleared by briefly pushing the QUICK-CAL button, which will force the positioner to use the parameters from the last good calibration. This error may appear on some very small actuators during the initial calibration. Redoing the calibration may clear the problem.
R - - -		Any sequence starting with a red light indicates that there is an operational problem with the unit.
RGRR	24	Position deviation (user-set) The position has exceeded user-defined error band between command and position.
RGYY	25	Pressure reading out of range The internal pressure sensors are either saturated with a pressure over 150 psi or the sensor has failed. Check supply pressure and if OK check the pressure sensor board connections and replace pressure sensor board if necessary.
RGYR	26	Loss of supply pressure The Positioner has determined that the supply pressure is below 15 psi. Check the supply pressure and if OK check the pressure sensor board connections and replace pressure sensor board if necessary. Minimum recommended supply pressure is 30 psi for proper operation.
RYYY	27	Pilot relay non-motion alert Check to make sure the air supply is connected. Also check the internal wiring harnesses for good connections. This error may be cleared by briefly pushing the QUICK-CAL button, which will force the positioner to use the parameters from the last good calibration. If the positioner still does not operate replace the pneumatic relay assembly.
RYYR	28	Pilot relay lower position alert Check to make sure the air supply is connected. Also check the internal wiring harnesses for good connections. This error may be cleared by briefly pushing the QUICK-CAL button, which will force the positioner to use the parameters from the last good calibration. If the positioner still does not operate replace the pneumatic relay assembly.

Colors	Identifier	Indication and Resolution
RYRY	29	Pilot relay upper position alert Check to make sure the air supply is connected. Also check the internal wiring harnesses for good connections. This error may be cleared by briefly pushing the QUICK-CAL button, which will force the positioner to use the parameters from the last good calibration. If the positioner still does not operate replace the pneumatic relay assembly.
RRGG	30	Watchdog timer timeout (also listed as internal voltage reference) This is often caused when intermittent operation occurs when connecting power. Remove power and then reconnect to clear. If problem persists it is a bad electronic assembly, replace.
RRYG	31	Internal temperature alert The internal positioner temperature is currently exceeding operational limits of -40°F (-40°C) or 185°F (85°C).
RYYR	32	Piezo voltage error Bad electronic assembly, replace.
RRYR	33	Internal voltage reference error Indicates that the circuit board is drawing too much power. Check internal wiring and connectors for electrical shorts—if no shorts are present, replace the electronic assembly.
RRRY	34	NV RAM checksum error The checksum of the internal data was not updated correctly. Cycle power and complete a QUICK-CAL if error persists. Check internal data to verify correct settings. If the error still occurs, replace the electronic assembly.

7.11 Version Number Checking

The version number of the embedded code may be checked at any time except during a calibration by holding down the up arrow Jog button (↑). This will not alter the operation of the unit other than to change the blink sequence to three blinks indicating the major version number. Holding the down arrow Jog button (↓) will give the minor version number without affecting operation. The version codes are interpreted by adding up the numbers assigned according to the following table:

Color	First blink value	Second blink value	Third blink value
Green	0	0	0
Yellow	9	3	1
Red	18	6	2

For example if holding the up arrow Jog button (↑) gave a G-G-R code, and holding the down arrow Jog button (↓) gave a Y-Y-G code then the resulting version number would be (0+0+2).(9+3+0) or version 2.12.

7.12 SoftTools™ Configuration and Diagnostic Software and HART 275/375 Handheld Communicator

Flowserve Corporation has written custom configuration and diagnostic software for the Logix 3200/Q digital positioner called *SoftTools™*. This software and the *SoftTools* Quick Start Guide are available from a Flowserve representative.

The Logix 3200/Q digital positioner supports and is supported by the HART 275/375 Handheld Communicator. The Device Description (DD) files and the manuals listed below can be obtained from the HART Communication Foundation or from your Flowserve representative. For more information please see the following guides:

- Product Manual for the HART Communicator.
- Logix 3200/Q Digital Positioner with HART 275/375 Communicator User Guide.

Diagnostic features such as the datalog, signature tests, and ramp tests are performed using the *SoftTools* software. Certain calibration features such as loop calibration, analog output calibration, and actuator pressure sensor calibrations are performed using the HART 275/375 Handheld Communicator or using diagnostic software such as *SoftTools*.

8 Maintenance and Repair

8.1 Driver Module Assembly

The driver module assembly moves the spool valve by means of a differential pressure across its diaphragm. Air is routed to the driver module from the regulator through a flexible hose. A barbed fitting connects the flexible hose to the driver module assembly. Wires from the driver module assembly connect the hall effect sensor and the piezo valve modulator to the main PCB assembly.

Driver Module Assembly Replacement

To replace the driver module assembly, refer to Figures 11-15 and 25 and proceed as outlined below. The following tools are required:

- Flat plate or bar about 1/8" thick
- Phillips screwdriver
- 1/4" nutdriver

⚠ WARNING: Observe precautions for handling electrostatically sensitive devices.

Figure 11: Driver Module Assembly

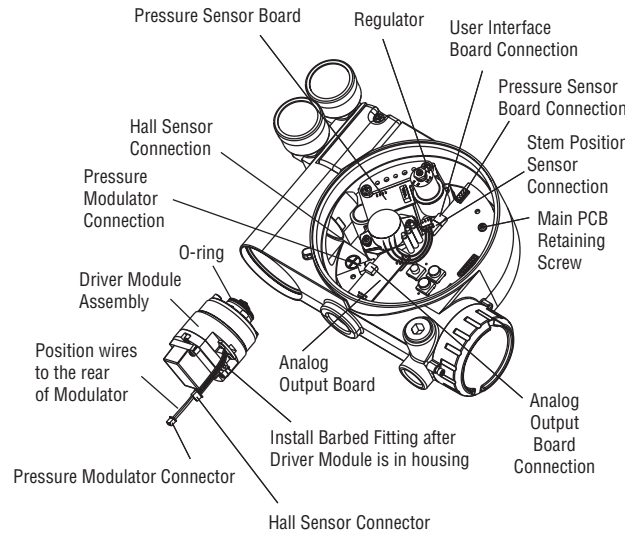
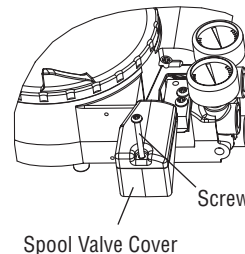

Figure 12: Spool Valve Cover Assembly



1. Make sure the valve is bypassed or in a safe condition.
2. Disconnect the power and air supply to the unit.
3. Remove the driver module cover (Figure 14), using a flat bar or plate in the slot to turn the cover.
4. Remove the spool valve cover by removing the screw and sliding the cover assembly backwards until the tab is clear of the slot (Figure 12). The sheet metal cap, hydrophobic filter, and O-ring should be removed with the spool valve cover. It is not necessary to take these parts out of the spool valve cover.
5. Being careful not to lose the nylon washer, remove the Phillips-head screw that attaches the driver module to the main housing (Figure 13).

- ⚠ **WARNING:** Spool (extending from the driver module assembly) is easily damaged. Use extreme caution when handling spool and spool valve block. Do not handle the spool by the machined portions of spool. The tolerances between the block and spool are extremely tight. Contamination in the block or on the spool may cause the spool to hang.

Figure 13: Spool and Block

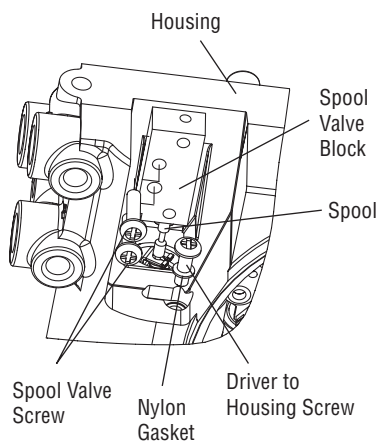
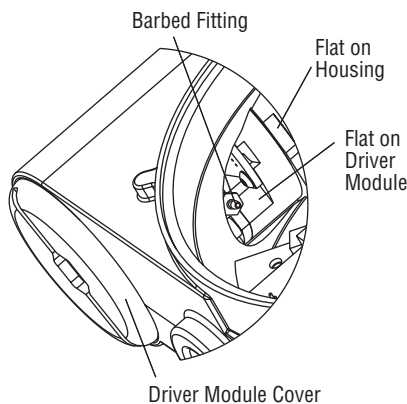

Figure 14: Driver Module Barbed Fitting



6. Remove the spool valve block by removing the two Phillips-head screws and carefully sliding the block off the spool (Figure 13).
7. Carefully remove the spool by sliding the end of the spool out of the connection clip. Excessive force may bend spool.
8. Remove the main cover.
9. Remove the plastic board cover by removing the three retaining screws (see Figure 14).
10. Disconnect the flexible tubing from the barbed fitting at the driver module assembly (see Figure 14).

11. Use the 1/4" nutdriver to remove the barbed fitting from the driver module assembly.
12. Unplug the two wiring connections that link the driver module assembly to the main PCB assembly.
13. Feed the two wires on the driver module back into the driver module compartment so that they stick out the driver module opening (see Figure 11). This will allow the driver module to thread out without tangling or cutting the wires.
14. Grasp the base of the driver module and turn it counterclockwise to remove. After it is threaded out, carefully retract the driver module from the housing.
15. Remove the barbed fitting from the side of the new driver module using the 1/4" nutdriver.
16. Verify that the O-ring is in place on the top of the new driver module. Lay the wires back along the side of the driver module as shown in Figure 11 and hold the wires in position by hand.
17. Gently insert the driver module into the driver module compartment in the housing. Turn the driver module clockwise to thread it into the housing. Continue rotating the driver module until it bottoms out.
18. Once the driver module has bottomed out so that the threads are fully engaged, rotate the driver module counter clockwise until the flat on the driver module and the flat on the housing are aligned. This will align the screw hole for the next step.
19. Verify that the nylon gasket is in the counter bore in the driver module retaining screw hole as shown in Figure 13.
20. Insert a driver-to-housing screw into the driver housing through the counterbored hole in positioner main housing. Tighten with a Phillips screwdriver.
21. Reach through the main compartment into the driver module compartment of the positioner and install the barbed fitting on the side of the driver module using the 1/4" nutdriver.

NOTE: Do not mix the barbed fitting with those from older Logix positioners. Older models contain orifices that will not work in the Logix 3200/Q model. Orifices are brass-colored, barbed fittings are silver-colored.

22. Reconnect the flexible tube coming from the regulator to the barbed fitting.
23. Feed the driver module wires into the main chamber of the housing, and connect them to the main PCB Assembly.
24. Verify that the three O-rings are in the counterbores on the machined platform where the spool valve block is to be placed (Figure 25).

25. Carefully slide the spool into the connecting clip on the top of the driver module assembly.
26. Carefully slide the block over the spool, using the machined surface of the housing base as a register (Figure 13). Slide the block toward the driver module until the two retaining holes line up with the threaded holes in the base.
27. Install two spool-valve screws and tighten securely with a Phillips screwdriver (see Figure 13).
28. Slide the spool valve cover assembly over the spool valve until the tang engages into the housing slot. Install spool valve cover screw and tighten securely (see Figure 12).
29. Install the plastic board cover. Insert the three retaining screw through the plastic cover into the threaded boss and tighten evenly, using a Phillips screwdriver. Do not overtighten (see Figure 15).
30. Reconnect power and air supply to the positioner and perform a stroke calibration.
31. Reinstall all covers.

Figure 15: Main PCB Assembly

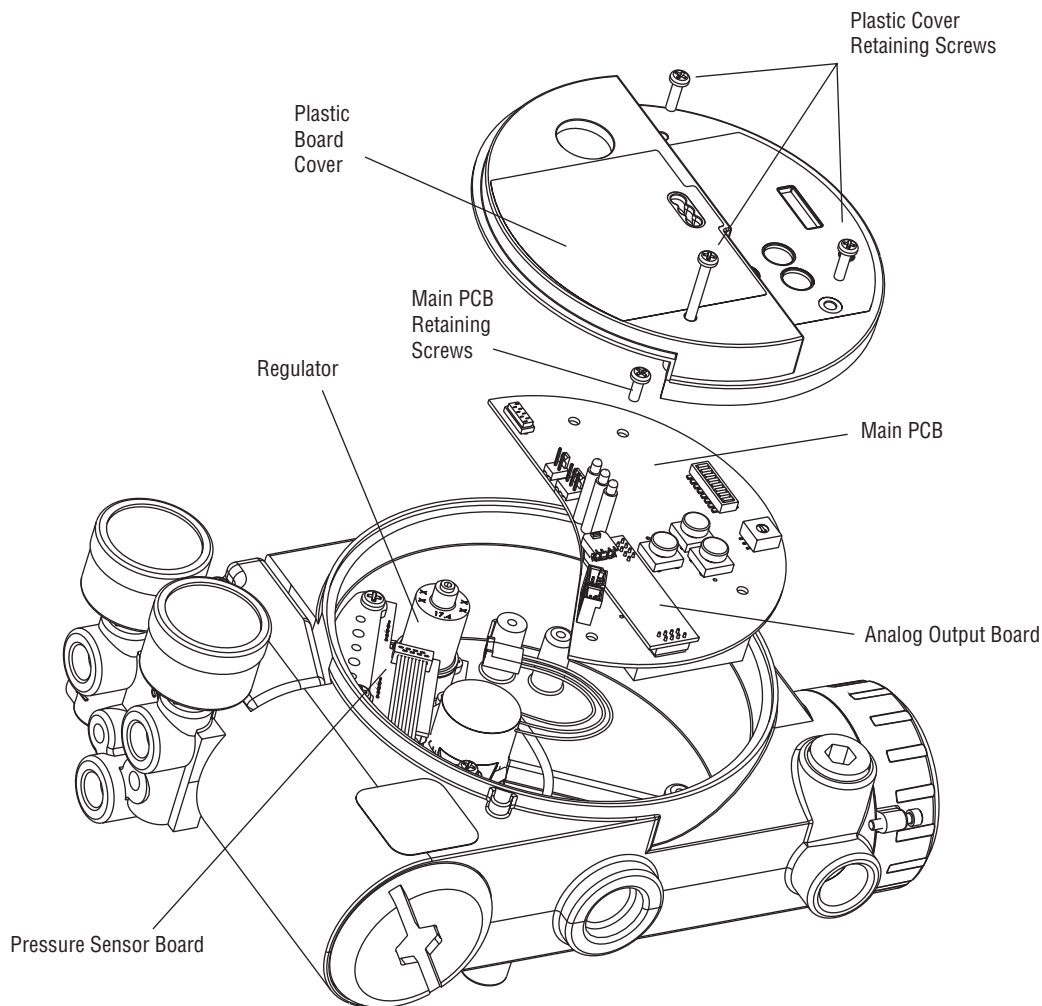

8.2 Regulator

The regulator reduces the pressure of the incoming supply air to a level that the driver module can use.

Replacing Regulator

To replace the regulator, refer to Figures 11 and 15 and proceed as outlined below. The following tools are required:

- Phillips screwdriver
- ¼" nutdriver

⚠ WARNING: Observe precautions for handling electrostatically sensitive devices.

1. Make sure valve is bypassed or in a safe condition.
2. Disconnect the power and air supply to the unit.
3. Remove the main cover.
4. Remove the plastic board cover by removing the three retaining screws (see Figure 15).
5. Remove the five wire connections from the main PCB assembly (six wire connections if the unit is equipped with the 4-20 mA analog output option).
6. Remove the retaining screw from the main PCB assembly and lift the main PCB out of the housing.
7. Remove the four screws from the regulator base. Verify that as regulator is removed, the O-ring and filter remain in the counterbore (please see Figure 11).
8. Remove tubing and barbed fitting from the regulator base.
9. Install barbed fitting and tubing to the new regulator.
10. Verify O-ring and filter are in the counterbore. Install new regulator using 8-32 x ½" screws.

NOTE: Do not mix the regulator with those from older Logix positioners. Older models contain regulators with different settings that will not work in the Logix 3200/Q model. The regulator pressure setting is printed on the top of the regulator. The Logix 3200/Q regulator is set to 17.4 psig.

11. Install the main PCB into the housing. Insert the retaining screw through the board into the threaded boss and tighten evenly, using a Phillips screwdriver. Do not overtighten.
12. Reinstall the five wire connections (six wire connections if the unit is equipped with the 4-20 mA analog output option).
13. Install the plastic board cover. Insert the three retaining screws through the plastic cover into the threaded boss and tighten

evenly, using a Phillips screwdriver. Do not overtighten (see Figure 15).

14. Reinstall all covers.

8.3 Checking or Setting Internal Regulator Pressure

To check or set the internal regulator pressure, refer to Figure 16 and proceed as outlined below. The tools and equipment used in the next procedure are from indicated vendors. The following tools are required:

- Calibrated pressure gauge (0 to 30 psi)
- ¼" flexible tubing
- Barbed Tee (Clippard Minimatic part number T22-2 or equivalent)
- ⅜" Allen wrench
- ⅜" open-end wrench

⚠ WARNING: Observe precautions for handling electrostatically sensitive devices.

Figure 16: Driver Module Regulator Pressure Check

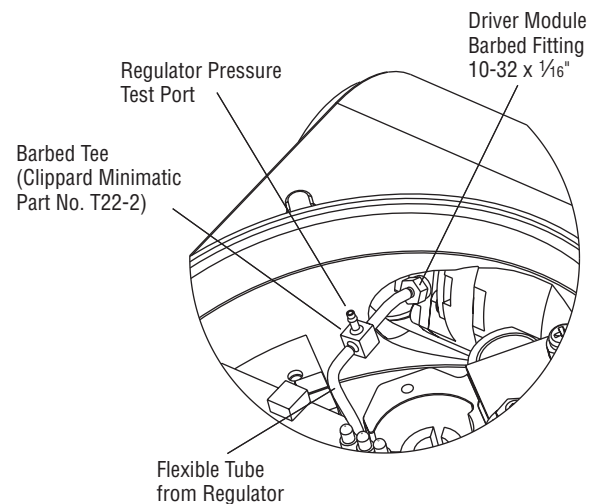

1. Make sure the valve is bypassed or in a safe condition.
2. Remove the main cover.
3. Remove the plastic board cover by removing the three retaining screws.
4. Remove the ¼" flexible tubing from the barbed fitting on the side of the driver module.

5. Obtain a barbed tee and two pieces of 1/16" flexible tubing, a few inches in length each.
6. Position the barbed tee between the internal regulator and the driver module by connecting the 1/16" flexible tubing, found in the positioner, to one side of the barbed tee. Using one of the new flexible tubing pieces, connect the barbed tee to the barbed fitting on the side of the driver module. Connect the remaining port on the barbed tee to a 0 to 30 psi pressure gauge.
7. Reconnect the air supply to the positioner and read the internal regulator pressure on the 0 to 30 psig gauge. The internal pressure should be set to 17.4 ±0.2 psig. If adjustment is needed, loosen the set screw retaining nut on the top of the regulator using the 3/8" open-end wrench. Then adjust the regulator pressure by turning the set screw on the top of the regulator with the 3/32" Allen wrench.
8. Once the regulator pressure is set, tighten the set screw retaining nut on the top of the regulator, remove the air supply to the positioner, remove the barbed tee, and reconnect the flexible tubing from the regulator to the barbed fitting on the side of the driver module.
9. Install the plastic board cover. Insert the three retaining screws through the plastic cover into the threaded boss and tighten evenly, using a Phillips screwdriver. Do not overtighten (see Figure 15).
10. Reinstall all covers.

8.4 Spool Valve

The spool valve routes the supply air to one side of the actuator while venting the opposite side (see Figure 1). The position of the spool valve is controlled by the driver module.

Replacing the Spool Valve

To replace the spool valve, refer to Figures 12, 14 and 25 and proceed as outlined below. The following tools are required:

- Phillips screwdriver
1. Make sure the valve is bypassed or in a safe condition.
 2. Disconnect the power and air supply to the unit.
 3. Remove the spool valve cover by removing the screw and sliding the cover assembly backwards until the tab is clear of the slot. It is not necessary to remove the sheet metal cap, hydrophobic filter, or O-ring from this assembly (Figure 14).

☠ **WARNING:** The spool (extending from the driver module assembly) is easily damaged. Use extreme caution when handling spool and spool valve block. Do not handle the spool by the machined portions of spool. The tolerances between the block and spool are extremely tight. Contamination in the block or on the spool may cause the spool to hang.

4. Remove the spool valve block by removing the two Phillips-head screws and carefully sliding the block off the spool (Figure 12).
5. Carefully remove spool by sliding end of spool out of connecting clip. Excessive force may bend the spool.
6. Verify that the three O-rings are in the counterbores on the machined platform where the new spool valve block is to be placed (Figure 25).
7. Carefully slide the spool into the connecting clip of the driver module assembly.
8. Carefully slide the block over the spool, using the machined surface of the housing base as a register (Figure 12). Slide the block toward the driver module until the two retaining holes line up with the threaded holes in the base.
9. Install two spool valve screws and tighten securely with a Phillips screwdriver (see Figure 13).
10. Slide the spool valve cover assembly over the spool valve until the tang engages into the housing slot. Install the spool valve cover screw and tighten securely (see Figure 12).
11. Reconnect power and air supply to the positioner and perform a stroke calibration.

8.5 Spool Valve Cover

The spool valve cover incorporates a coalescing filter element in a two-piece cover. This protects the spool valve chamber from dirt and moisture and provides a low back pressure vent for exhaust air from the spool valve.

Replacing Filter in Spool Valve Cover

To replace the filter in the spool valve cover, refer to Figures 12 and 17 and proceed as outlined below. The following tools are required:

- Phillips screwdriver
1. Remove the spool cover by removing the screw and sliding the cover assembly backwards until the tab is clear of the slot. The sheet metal cover may be removed and cleaned with a brush or by blowing out with compressed air (Figure 12).
 2. Remove the O-ring from around the hydrophobic filter element and set aside (Figure 17).

3. Remove the molded filter element by pulling it straight out of the chamber cover vent piece.
4. Install O-ring into base of chamber cover vent piece as shown in Figure 17.
5. Place new molded filter element into the chamber cover vent piece. This filter element provides part of the track to secure the O-ring installed in the last step.
6. Place spool valve shroud onto spool valve cover.
7. Place the spool valve cover assembly in place by setting it on the ramp and sliding it until the tab seats in the slot (Figures 12 and 17) and secure with a 8-32 screw.
4. Remove the plastic board cover by removing the three retaining screws (see Figure 15).
5. Disconnect the position sensor wires from the main PCB assembly.
6. Remove the two rotary position sensor-retaining screws and lift the sensor out of the housing.
7. Turn the new position sensor shaft until the dot on the side of the shaft is aligned with the wires on the side of the position sensor (Figure 18).
8. Insert the position sensor into the shaft with the wires pointing toward the main PCB assembly. Turn the position sensor clockwise until bolting slots align with the housing screw holes and the wires on the sensor protrude over the main PCB assembly.

Figure 17: Spool Valve Cover Assembly

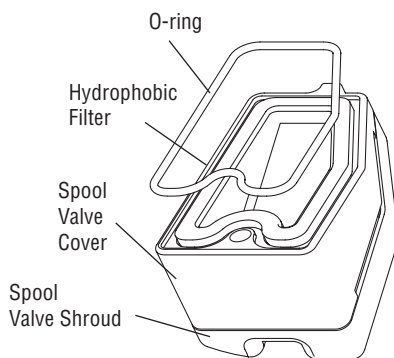

8.6 Stem Position Sensor

The position feedback assembly transmits valve positions information to the processor. This is accomplished by means of a rotary position sensor that connects to the valve stem through a feedback linkage. To provide for accurate tracking of the pin in the slot, the follower arm is biased against one side of the slot with a rotary spring. This spring also automatically moves the position feedback assembly to its limit in the unlikely event of failure of any component in the linkage.

Stem Position Sensor Replacement

To replace the stem position sensor, refer to Figure 15, 18 and 25 and proceed as outlined below. The following tools are required:

- Phillips screwdriver

⚠ WARNING: Observe precautions for handling electrostatically sensitive devices.

1. Make sure the valve is bypassed or in a safe condition.
2. Disconnect the power and air supply to the unit.
3. Remove the main cover.

9. Carefully center the position sensor on the shaft bore, insert and tighten the screws. Do not overtighten.
10. Route the wires along the side of the position sensor and reconnect to the main PCB assembly.
11. Install the plastic board cover. Insert the three retaining screws through the plastic cover into the threaded boss and tighten evenly, using a Phillips screwdriver. Do not overtighten (see Figure 15).
12. Reinstall all covers.
13. Reconnect power and air supply to the positioner and perform a stroke calibration.

Note: Do not mix the position sensor with those from older Logix positioners. Older models contain sensors with different ranges that will not work in the Logix 3200/Q model. The wires on the Logix 3200/Q position sensor are red, white and black.

8.7 Main PCB Assembly

The main printed circuit board (PCB) assembly contains the circuit board and processor that perform control functions of the positioner. The main PCB is to be replaced as a unit. None of the components on the main PCB are serviceable.

Replacing Main PCB Assembly

To replace the main PCB assembly, refer to Figure 11 and 15 and proceed as outlined below. The following tools are required:

- Phillips screwdriver

⚠ WARNING: Observe precautions for handling electrostatically sensitive devices.

1. Make sure the valve is bypassed or in a safe condition.

Figure 18: Stem Position Sensor Orientation

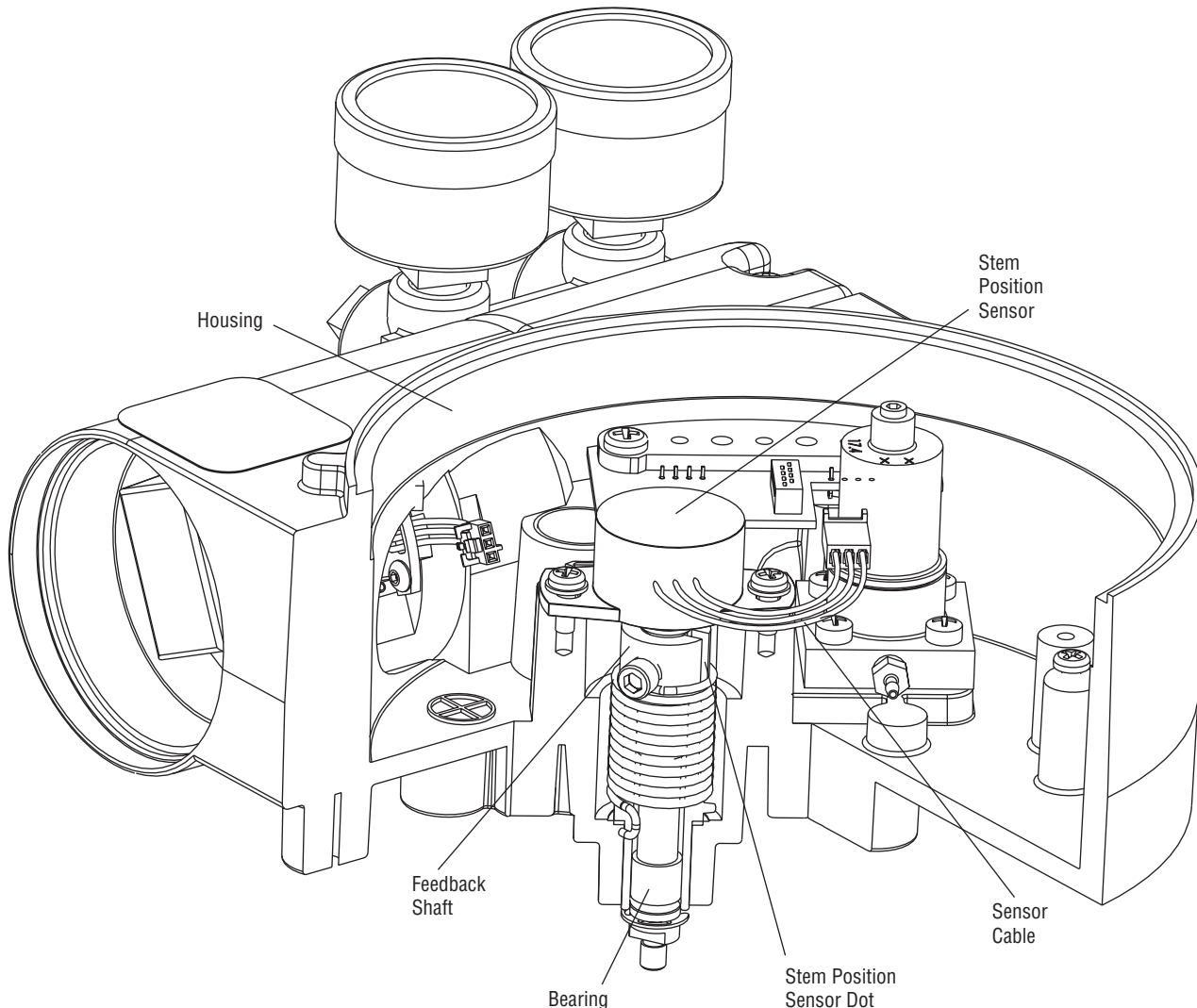

2. Disconnect the power and air supply to the unit.
3. Remove the main cover.
4. Remove the plastic board cover by removing the three retaining screws (see Figure 15).
5. Remove the five wire connections from the main PCB assembly (six wire connections if the unit is equipped with the 4-20 mA analog output option) (see Figure 11).
6. Remove the retaining screw from the main PCB assembly and lift the main PCB out of the housing (see Figure 15).
7. Install the new main PCB into the housing. Insert the retaining screw through the board into the threaded boss and tighten, using a Phillips screwdriver. Do not overtighten.
8. If the old main PCB is equipped with a 4-20 mA analog output board, gently lift the board off the main PCB. Align the two connectors of the 4-20 mA output board with the mating sockets on the main PCB and gently press the connectors together.
9. Reinstall the five wire connections (six wire connections if the unit is equipped with the 4-20 mA analog output option) (see Figure 11).
10. Install the plastic board cover. Insert the three retaining screws through the plastic cover into the threaded boss and tighten evenly, using a Phillips screwdriver. Do not overtighten (see Figure 15).
11. Reinstall all covers.
12. Reconnect power and air supply to the positioner and reconfigure the positioner being sure to perform a stroke calibration.

8.8 Pressure Sensor Board

On advanced model Logix 3200/Q positioners, a pressure sensor board is installed in the positioner. The pressure sensor board contains two pressure sensors that measure the pressure on output ports 1 and 2. The main PCB electronics automatically senses the presence of the pressure sensor board. If present, the actuator pressure sensors are used in the positioner control algorithm to enhance valve stability. For optimal performance, the actuator pressure sensors need to be calibrated. The actuator pressure sensor calibration is performed using a HART 275/375 Handheld Communicator or configuration software such as SoftTools.

In the standard model, the pressure sensor board is replaced by a plate that plugs the actuator pressure sensor ports. This plate can be replaced by a pressure sensor board to field-upgrade a standard model to an advanced model.

Removing the Pressure Sensor Board (Advanced Model)

To replace the pressure sensor board, refer to Figures 11, 15 and 25 and proceed as outlined below. The following tools are required:

- Phillips screwdriver

⚠ WARNING: Observe precautions for handling electrostatically sensitive devices.

1. Make sure the valve is bypassed or in a safe condition.
2. Disconnect the power and air supply to the unit.
3. Remove the main cover.
4. Remove the plastic board cover by removing the three retaining screws (see Figure 15).
5. Disconnect the ribbon cable on the pressure sensor board from the PCB assembly (see Figure 11).
6. Remove the two screws holding the pressure sensor board to the housing. Lift the metal stiffener plate off the pressure sensor board and set aside for future use.
7. Remove the pressure sensor board.

Removing the Pressure Sensor Plug Plate (Standard Model)

To upgrade a standard model to an advanced model, the pressure sensor plug plate must be removed and replaced by a pressure sensor board. The main PCB electronics automatically senses the presence of the pressure sensor board. If present, the actuator pressure sensors are used in the positioner control algorithm to enhance valve stability. For optimal performance, the actuator pressure sensors need to be calibrated. The actuator pressure sensor calibration is performed using a HART 275/375 Handheld Communicator or configuration software such as SoftTools. To upgrade a standard

model to an advanced model, refer to Figures 11, 15 and 25 and proceed as outlined below. The following tools are required:

- Phillips screwdriver
1. Make sure the valve is bypassed or in a safe condition.
 2. Disconnect the power and air supply to the unit.
 3. Remove the main cover.
 4. Remove the plastic board cover by removing the three retaining screws (see Figure 15).
 5. Remove the two screws holding the pressure sensor plug plate to the housing. Lift the metal stiffener plate off the pressure sensor plug plate and set aside for future use.
 6. Remove the pressure sensor plug plate and discard.

Installing the Pressure Sensor Board (Advanced Model)

The pressure sensor board is installed on the advanced model only. To install the pressure sensor board, refer to Figures 11, 15 and 25 and proceed as outlined below. The following tools are required:

- Phillips screwdriver
- Torque wrench

⚠ WARNING: Observe precautions for handling electrostatic sensitive devices.

1. Verify that the two pressure sensor O-rings (item 15) are in place in the housing.
2. Set the pressure sensor board assembly in place so that the O-rings make contact with the faces of the pressure sensors.
3. Place the metal stiffener plate (item 12) on top of the pressure sensor board over the pressure sensors and align the two holes in the pressure sensor plate with the threaded bosses in the housing.
4. Insert two screws through the stiffener plate and pressure sensor board into the threaded holes in the housing and tighten evenly, to 8 in-lb.
5. Connect the ribbon cable on the pressure sensor board to the main PCB assembly.
6. Install the plastic board cover. Insert the three retaining screws through the plastic cover into the threaded boss and tighten evenly, using a Phillips screwdriver. Do not overtighten.
7. Reinstall all covers.
8. Reconnect power and air supply to the positioner. Use SoftTools or a handheld communicator to perform a pressure sensor calibration.

8.9 Customer Interface Board

The customer interface board provides a connection point inside the explosion-proof housing for all hookups to the positioner. Calibration of the loop current and the analog output current (optional) are performed using a HART 275/375 Handheld Communicator or configuration software such as SoftTools.

Replacing the Customer Interface Board

To replace the customer interface board, refer to Figures 6, 11, 15 and 25 and proceed as outlined below. The following tools are required:

- Phillips screwdriver

⚠ WARNING: Observe precautions for handling electrostatic sensitive devices.

1. Make sure the valve is bypassed or in a safe condition.
2. Disconnect the power and air supply to the unit.
3. Remove the main cover.
4. Remove the plastic board cover by removing the three retaining screws (see Figure 15).
5. Remove the five wire connections from the main PCB assembly (six wire connections if the unit is equipped with the 4-20 mA analog output option) (see Figure 11).
6. Remove the retaining screw from the main PCB assembly and lift the main PCB out of the housing (see Figure 15).
7. Remove the user interface cover.
8. Disconnect the field wiring from the customer interface board terminals and remove the three screws that hold the customer interface board in the housing (see Figure 6).
9. Remove the customer interface board, carefully pulling the wiring through the bore.
10. Verify that the O-ring is in place in the counterbore in the positioner housing.
11. Feed the wires on the back of the new customer user interface board through the passageway into the main chamber of the housing.
12. Set the customer interface board in place and secure with three screws (see Figure 6).

13. Reconnect the field wiring to the customer interface board terminals.
14. Install the main PCB into the housing. Insert the retaining screw through the board into the threaded boss and tighten evenly, using a Phillips screwdriver. Do not overtighten.
15. Reinstall the five wire connections (six wire connections if the unit is equipped with the 4-20 mA analog output option) on the main PCB assembly (see Figure 11).
16. Install the plastic board cover. Insert the three retaining screws through the plastic cover into the threaded boss and tighten evenly, using a Phillips screwdriver. Do not overtighten (see Figure 15).
17. Reinstall all covers.

9 Optional Hardware

9.1 Vented Design (See Figures 19 and 20)

A standard Logix 3200/Q positioner is vented directly to the atmosphere. When supply air is substituted with sweet natural gas, piping must be used to route the exhausted natural gas to a safe environment. This piping system may cause some positioner back pressure in the main chamber (from the modulator and regulator) and spool chamber (from the actuator). Back pressure limitations are described below.

Two chambers must be vented on the Logix 3200/Q positioners: the main housing chamber and the spool valve chamber (Figures 19 and 20). The main chamber vent is located on the backside of the positioner (see Figure 19). Vented-design Logix 3200/Q positioners are supplied from the factory with a fitting installed in the main chamber vent. Connect the necessary tubing/piping to this fitting to route the exhausted natural gas to a safe environment.

The maximum allowable back pressure from the collection device on the main housing vent is 2.0 psig (0.14 barg). Vent flow rate is 0.5 std ft³/min (1.4 std liter/min).

⚠ WARNING: The back pressure in the main housing must never rise above 2.0 psig (0.14 barg).

Figure 19: Main Housing Vent

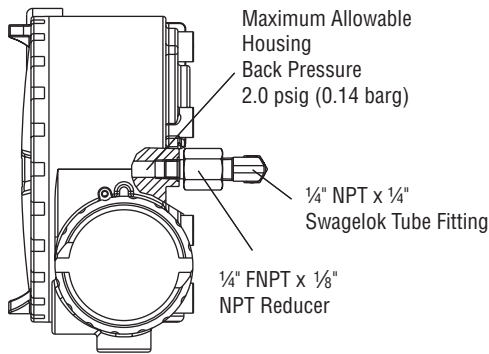
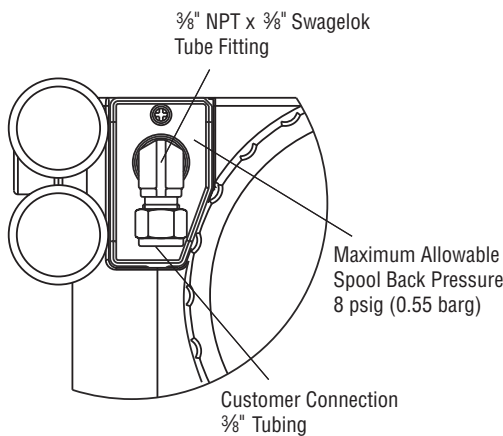
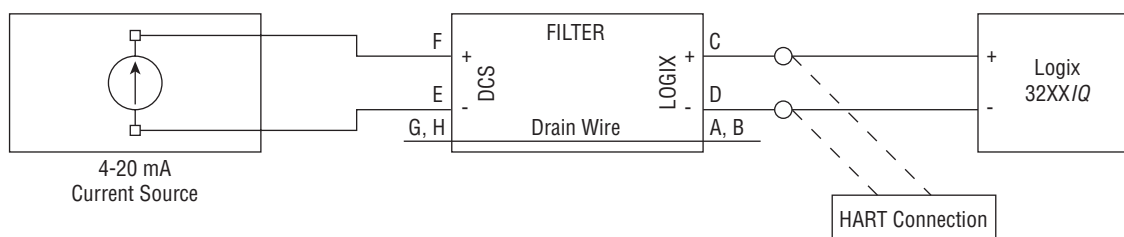

Figure 20: Spool Cover Vent



The spool valve chamber (see Figure 20) must also be vented through the spool valve cover. Vented-design Logix 3200/IQ positioners are supplied from the factory with a fitting installed in the spool valve cover (item SKU 179477). Connect the necessary tubing/piping to this fitting to route the exhausted natural gas to a safe environment. The maximum allowable back pressure in the spool valve chamber is 8 psig (0.55 barg). Pressures greater than 8 psig will cause vented gas to leak past the spool cover O-ring to the atmosphere and will result in overshoot of the positioner.

Figure 22: HART VHF Filter Schematic



9.2 HART VHF Filter

HART communication superimposes two frequencies, 1200 Hz and 2200 Hz, on the DC 4-20 mA current signal. Some current sources (DCS or 4-20 mA calibrator) can interfere with the HART signal. This may prevent communication with SoftTools or the HART 275/375 handheld. Intermittent communication may also be the result of a HART incompatible current source. In this case, a filter is necessary between the current source and Logix 3200 to allow HART communication.

Flowserve makes a filter (Part No. 139774) that must be used on each 4-20 mA line if the current source interferes with communication (see Figure 21). The filter does not affect the DC current but prevents the source from affecting the HART frequencies. The filter comes in a DIN rail-mount package.

Figure 21: HART VHF Filter



NOTE: This filter is not rated for use in hazardous areas. It should be located between the current source and the barrier in intrinsically safe applications.

9.3 HART Modem

The HART modem is a device that connects to the serial communications port of a computer. This modem converts the RS-232 COM port signals to the HART signal. A HART modem is optional in SoftTools since a MUX can be used in its place. The HART modem takes power from the RS-232 COM port lines. If using a laptop computer running on an internal battery, HART communication may become erratic as the batteries begin to lose charge. This is due to a reduction in HART modem power. Allow batteries to recharge or apply AC adapter power to the laptop to correct the problem. A HART modem is available through your Flowserve representative. (Please refer to Section 11 for part numbers.)

When using a HART modem with SoftTools or when using the HART 275/375 handheld, the leads can be connected anywhere across the 4-20 mA current signal. The leads are not polarity sensitive. When using a filter, the connection must be made between the filter output and the Logix 3200/Q (see Figure 22).

9.4 4-20 mA Analog Output Board

The Logix 3200/Q digital positioner can be supplied to provide an analog feedback signal of the stem position. This option can also be retrofitted in the field. The 4-20 mA analog output board is wired in series with a 12.5 to 40 VDC power supply (see Figure 23). This position feedback option has the following features and specifications:

- Does not interfere with positioner operation.
- Calibration of the analog output signal is performed using a HART 275/375 Handheld Communicator or configuration software such as SoftTools.
- Output follows actual position of valve, including all failure modes of positioner except loss of power. An output of ≤ 3.15 mA is transmitted with loss of power to the positioner.
- Immune to RFI/EMI disturbances.
- Available for explosion-proof and safe applications (CSA, FM).

Replacing the 4-20 mA Analog Output Board

To replace the 4-20 mA analog output board, refer to Figures 11, 15 and 25 and proceed as outlined below. The following tools are required:

- Phillips screwdriver

WARNING: Observe precautions for handling electrostatically sensitive devices.

Figure 23: Analog Output Board Power

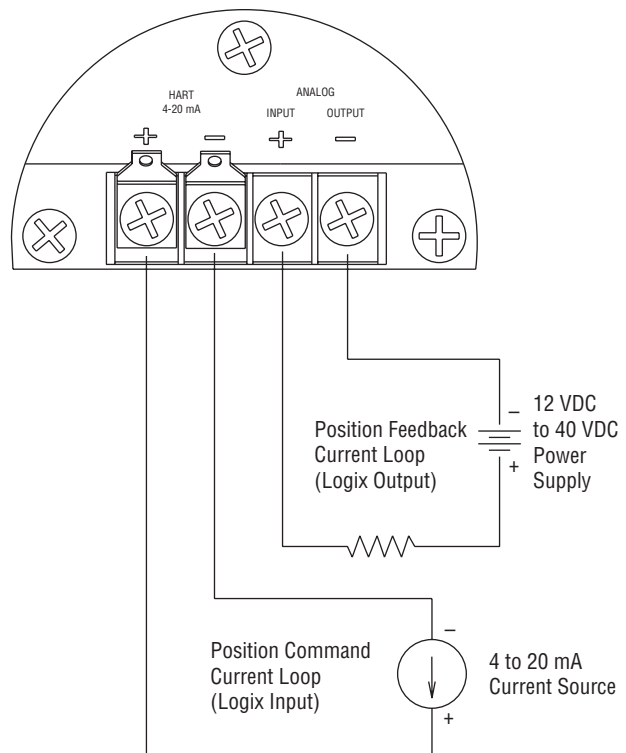

CAUTION: Isolated power sources required.

1. Make sure the valve is bypassed or in a safe condition.
2. Disconnect the power and air supply to the unit.
3. Remove the main cover.
4. Remove the plastic board cover by removing the three retaining screws (see Figure 15).
5. Disconnect the two wire connection from the side of the 4-20 mA analog output board.
6. Gently lift the 4-20 mA analog output board off the main PCB assembly.
7. Align the two connectors on the new 4-20 mA analog output board with the mating sockets on the main PCB board and gently press the connectors together.
8. Connect the two wire connection coming from the User Interface board to the side of the 4-20 mA analog output board.
9. Install the plastic board cover. Insert the three retaining screws through the plastic cover into the threaded boss and tighten evenly, using a Phillips screwdriver. Do not overtighten.
10. Connect the Analog Output filed termination wiring to the Analog Output terminals on the User Interface board (see Figure 23.)
11. Reinstall all covers.

Figure 24: 4-20 mA Analog Output Board

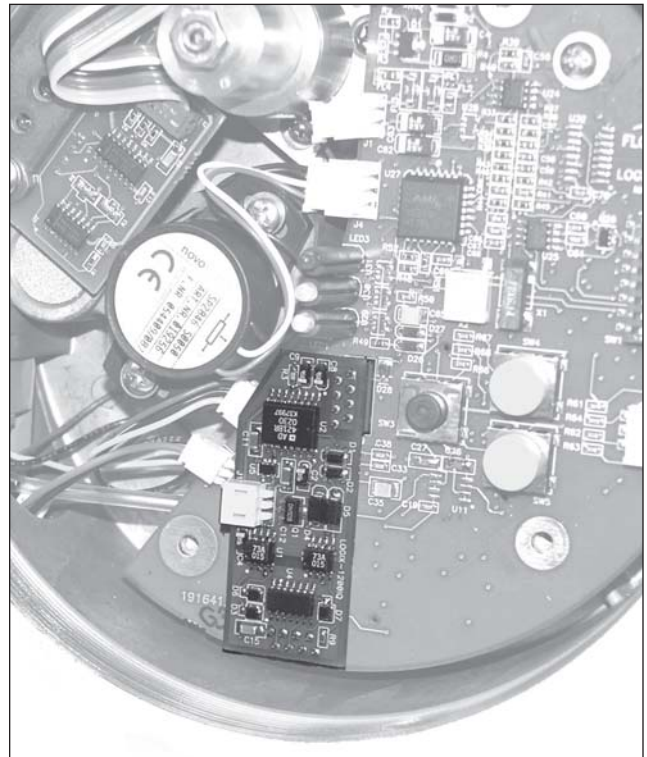

10 Parts List

Item No.	Part
1	Housing Logix 3000/Q Positioner
2	Main Housing Cover
3	O-ring, Main Housing Cover
4	Screw, Anti-rotation
5	Plastic Main PCB Cover
6	Screw, Main PCB Cover Short (2)
7	Screw, Main PCB Cover Long
8	Main PCB Assembly
9	Screw, Main PCB Assembly Retaining
10	4-20 mA Analog Output Board (Optional)
11	Screw, Pressure Sensor Board (2)
12	Pressure Sensor Board Stiffener
13	Pressure Sensor Board (Advanced Only)
14	Pressure Sensor Plug Plate (Standard Only)
15	O-ring, Pressure Sensor to Housing (2)
16	Pressure Regulator, 5 to 30 psig (Includes 2 O-rings)
17	Screw, Regulator Plate to Housing (4)
18	Hex Barbed Fitting with Captive O-ring
19	Internal Filter
20	O-ring, Interface Plate to Housing Seal
21	Customer Interface Cover
22	O-ring, Customer Interface Cover
23	Screw, Anti-rotation
24	Screw, Customer Interface Board (3)
25	Customer Interface Board
26	O-ring, Customer Interface Board
27	Grounding Screw (2)
28	Threaded Plug

Item No.	Part
29	Main Vent Cover
30	Screw, Main Vent Cover
31	Driver Module Cover
32	O-ring, Driver Module Cover
33	Driver Module Assembly
34	Hex Barbed Fitting with Captive O-ring
35	Flexible Tubing
36	Screw, Driver to Housing
37	Nylon Washer
38	Spool Valve
39	Spool Valve Block
40	Screw, Spool Valve to Housing (2)
41	O-ring, Spool Valve (3)
42	Screw, Spool Valve Cover
43	Spool Valve Shroud
44	Spool Valve Cover
45	Hydrophobic Filter, Spool Valve Chamber
46	O-ring, Spool Valve Cover
47	Pressure Gauge, 0-160 psig (2)
48	Air Screen (3)
49	Screw, Position Feedback Potentiometer to Housing (2)
50	Metal Washer (2)
51	Position Feedback Potentiometer
52	Feedback Shaft
53	Screw, Spring to Feedback Shaft
54	O-ring, Feedback Shaft
55	Torsion Spring
56	E-ring

Figure 25: Exploded Drawing

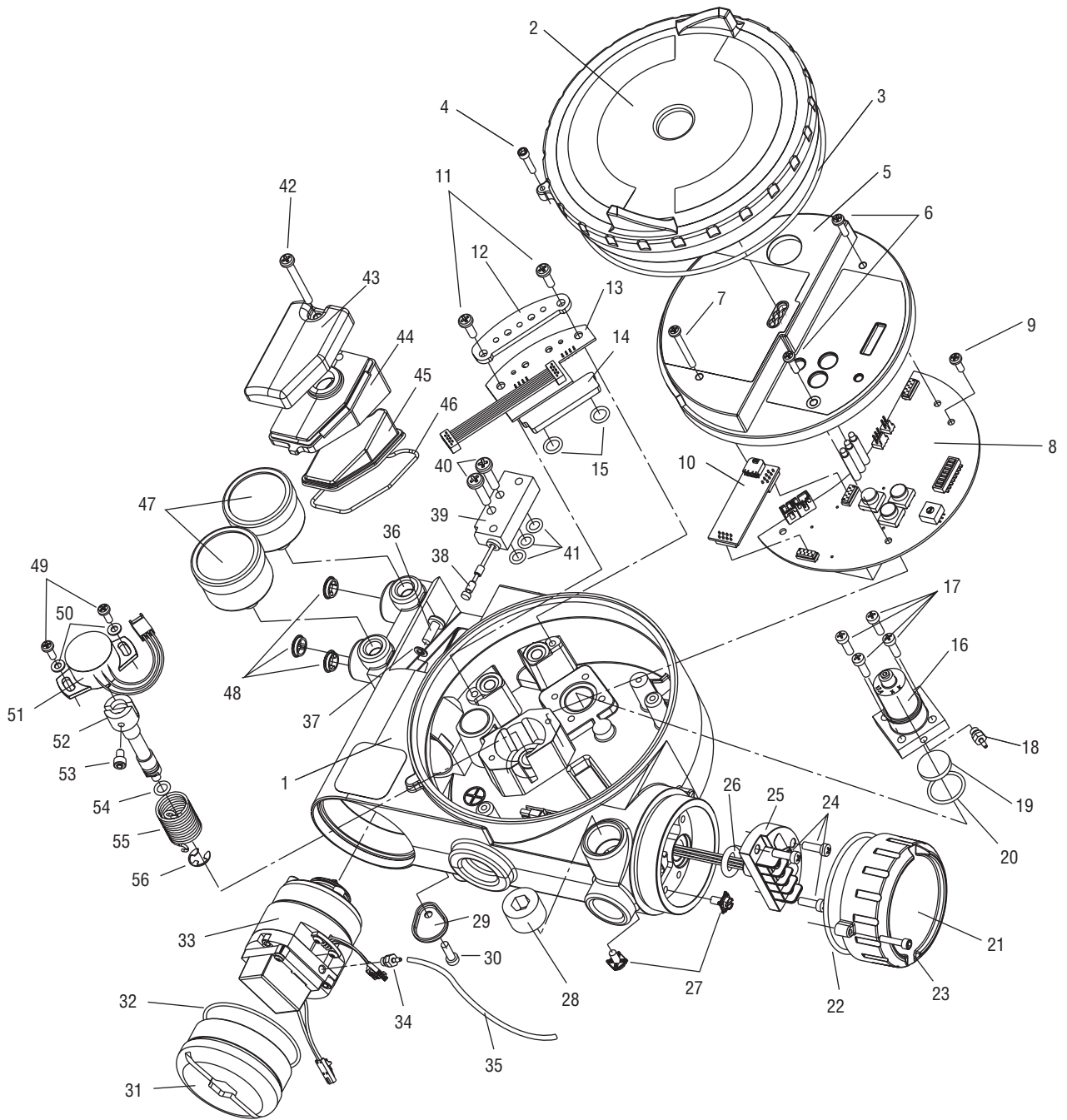

11 Logix 3200/Q Spare Parts Kits

See Figure 25 for item numbers.

Item No.	Description	Quantity
Kit 1: Driver Module Assembly -20° to 80°C Kit, P/N 218811.999.000		
16	Pressure Regulator	1
17	Screw, Regulator to Housing	4
33	Driver Module Assembly	1
34	Hex Barbed Fitting w/ Captive O-ring	1
36	Screw, Driver to Housing	1
37	Nylon Washer	1
Kit 2: Driver Module Assembly -40° to 80°C Kit, P/N 199786.999.000		
16	Pressure Regulator	1
17	Screw, Regulator to Housing	4
33	Driver Module Assembly	1
34	Hex Barbed Fitting w/ Captive O-ring	1
36	Screw, Driver to Housing	1
37	Nylon Washer	1
Kit 3: Spool Assembly Valve Kit, P/N 199787.999.000		
38	Spool	1
39	Spool Valve Block	1
40	Screw, Spool Valve to Housing	2
41	O-ring, Spool Valve	3
Kit 4: Pressure Regulator, P/N 215814.999.000		
16	Pressure Regulator with Captive O-rings	1
17	Screw, Regulator to Housing	4
Kit 5: Feedback Shaft Kit, P/N 199788.999.000		
52	Feedback Shaft	1
53	Screw, Spring to Feedback Shaft	1
54	O-ring, Feedback Shaft	1
55	Torsion Spring	1
56	E-ring	1
Kit 6: Feedback Shaft Kit (NAMUR), P/N 218814.999.000		
52	Feedback Shaft	1
53	Screw, Spring to Feedback Shaft	1
54	O-ring, Feedback Shaft	1
55	Torsion Spring	1
56	E-ring	1

Item No.	Description	Quantity
Kit 7: Soft Goods Kit, P/N 199789.999.000		
3	O-ring, Main Housing Cover	1
15	O-ring, Pressure Sensor to Housing	2
20	O-ring, Regulator to Housing	1
22	O-ring, Customer Interface Cover	1
26	O-ring, Customer Interface Board	1
35	Flexible Tube	1
37	Nylon Washer	1
41	O-ring, Spool Valve to Housing	3
45	Hydrophobic Filter, Spool Valve Chamber	1
46	O-ring, Spool Valve Cover	1
54	O-ring, Feedback Shaft	1
Kit 8: Standard Model Pressure Sensor Plug Plate Kit, P/N 199790.999.000		
11	Screw, Pressure Sensor Board	2
14	Pressure Sensor Plug Plate	1
15	O-ring, Pressure Sensor to Housing	2
Kit 9: Advanced Model Pressure Sensor Board Kit, P/N 199791.999.000		
11	Screw, Pressure Sensor Board	2
13	Pressure Sensor Board	1
15	O-ring, Pressure Sensor to Housing	2
Kit 10: Main PCB Assembly Kit, P/N 199792.999.000		
6	Screw, Main PCB Cover Short	2
7	Screw, Main PCB Cover Long	1
8	Main PCB	1
9	Screw, Main PCB Retaining Screw	1
Kit 11: User Interface Board Kit, P/N 199793.999.000		
24	Screw, Customer Interface to Housing	3
25	Customer Interface Board	1
26	O-ring, Customer Interface Board	1
Kit 12: Analog Output Board Kit, P/N 218795.999.000		
10	Analog Output Board	1
Kit 13: Position Feedback Potentiometer Kit, P/N 199794.999.000		
49	Screw, Feedback Potentiometer to Housing	2
50	Metal Washer	2
51	Position Feedback Potentiometer	1
HART Filter, P/N 139774.999.000		
HART Modem		
RS 232	P/N 138203.999.000	
PCMCIA	P/N 138204.999.000	
USB	P/N 216421.999.000	

12 Logix 3200/Q Mounting Kits

12.1 Valtek Mounting Kits

Table IX: Valtek Linear Mounting Kits

Spud	25 in ²		50 in ² *		100-200 in ²	
	Standard	Handwheel	Standard	Handwheel	Standard	Handwheel
2.00	164432	164433	164434	164433		
2.62			164435	164436	164437**	164436
2.88					164437	164438
3.38					164439	164440
4.75					164439	164440

* A 50 square", 2.00 spud with live loading requires kit number.

** Live-loading is not available on a 100 in², 2.62 spud.

Table X: Valtork Rotary Mounting Kits*

Spud	25 in ²		50 in ² *		100-200 in ²	
	Standard	Optional	Standard	Optional	Standard	Optional
0.44	135429	135432	135430		135431	
0.63	135429	135437	135430	135433	135431	
0.75	135429	135438	135430	137212	135431	
0.88	135429	135439	135430	137213	135431	135434
1.12	135429		135430	137214	135431	137215
1.50	135429		135430		135431	137216
1.75	135429		135430		135431	137217

* Standard: All rotary valves with standard accessories (end of shaft mount).

Optional: All rotary valves with handwheels or volume tanks (linkage design).

12.2 Logix O.E.M. Mounting Kits

Table XI: Logix O.E.M. Mounting Kits

Brand	Model	Size	Mounting Kit	
Fisher	657 & 667	30	213905	0.5" – 1.5" stroke
		34	141410	
		40		
		50	171516	0.5" – 1.5" stroke
			171517	2" stroke
		60	171516	0.5" – 1.5" stroke
			171517	2" stroke
		70	171518	4" stroke
	80	171519		
	1250	225	173371	
		450		
		675		
1052	33	171549	Rotary	
657-8	40	173798		
Neles	RC		171512	
	RD		178258	
Foxboro	Slid-Std		173567	
	Linear		178258	
Honeywell	VST-VA3R	17-in. dia.	173798	
	VSL-VA1D	12-in. dia.	173798	
Masoneilan (Linear Actuators)	37	9	171721	
		11		
		13		
		18		
		24		
	38	11	173235	
		13	173234	
		15	186070	
		18	173382*	
		24	173896	
	71 Domotor	25	173325	
		50	173335	
	88	100	173336	
		6	171722	
	47	16	173827	
		B	173361	
	48	B	173361	
		"D" Domotor	200	175141
	71-2057AB-D		176179	
	71-40413BD		176251	

Table XI: Logix O.E.M. Mounting Kits (continued)

Brand	Model	Size	Mounting Kit	
Masoneilan (Rotary Actuators)	33	B	173298	
	35	4	173298	
		6		
		7		
70	10	173298		
Valtek	Trooper		166636	0.75" – 1.50" Std
Automax	R314		141180	HD
	SNA115		NK313A	
Vanguard	37/64		175128	
Air-Torque	AT Series	AT0 – AT6	Consult factory	
Automax	SNA Series	SNA3 – SNA2000		
	N Series	N250.300		
	R Series	R2 – R5		
Bettis	RPC Series	RP – TPC11000		
	G Series	G2009-M11 – G3020-M11		
EL-O-Matic	E Series	E25 – E350		
	P Series	P35 – P4000		
Hytork	XL Series	XL45 – XL4580		
Unitorq	M Series	M20 – M2958		
Worcester	39 Series	2539 – 4239		

*Adjustable mounting kit 173798 may be needed if handwheels are used.

12.3 NAMUR Accessory Mounting Kit Part Numbers

Use prefix "NK" and choose bracket and bolt options from the following table.

Table XII: NAMUR Accessory Mounting Kit Part Numbers

Bracket Option	Description
28	20 mm pinion x 80 mm bolt spacing
28	38 mm pinion x 80 mm bolt spacing
313	30 mm pinion x 80 mm bolt spacing
513	50 mm pinion x 130 mm bolt spacing
Bolt Option	Description
A	10-24 UNC bolting
B	10-32 UNF bolting
L	M5-.8 metric bolting

Example: NK313A, NAMUR Accessory Mounting Kit with 30 mm pinion x 80 mm bolt spacing and 10-24 UNC bolting.

13 Frequently Asked Questions

Q: My DCS uses 24 VDC, can I run a Logix 3200IQ?

A: A DCS output current card does run from 24 VDC but the card regulates the actual current output. However, if the 24 VDC were applied directly across the terminals, nothing would limit the current and the Logix 3200/Q Field Termination Board could be damaged. The current source voltage supply can be anywhere between 10 VDC to 30 VDC as long as the current is limited in the 4-20 mA range.

Q: I accidentally placed a voltage supply across the Logix 3200IQ. How do I know if I damaged something?

A: The typical failure in an over-current situation is a short circuit. Your loop current will be maintained but the Logix 3200/Q control board will receive no power. With power removed from the Logix 3200IQ, use an ohmmeter to measure across the terminals. If the reading is a short (close to zero ohms), the Customer Interface Board must be replaced. Make sure the positive lead is on the '+' terminal and negative lead is on the '-' terminal when measuring the resistance.

Q: What is the input resistance of the Logix 3200IQ?

A: The Logix 3200/Q does not have a simple resistive input. When measuring the voltage across the Logix 3200IQ, it only varies slightly when the current is changed from 4 mA to 20 mA (9.8 to 10.0 VDC nominal without HART communications. Add 0.3 V with HART active). This is because the Logix 3200/Q is an active device. The resistance at a given current is commonly referred to as the effective resistance.

$\text{Effective Resistance} = (\text{Terminal Voltage}) / \text{Current}$	Equation 3
--	------------

For example:

at 20 mA: Effective resistance = 9.9 VDC/0.02 A = 495 Ω

The Logix 3200/Q has a specification of 495 Ω @ 20 mA.

NOTE: You cannot measure across the terminals of an unpowered Logix 3200 and get the effective resistance.

Q: How do I know if I need a VHF HART filter?

A: If the current source is interfering with communication, it will affect both SoftTools and the HART 275/375 handheld. If the positioner communicates to SoftTools or the HART 275/375 handheld when using a current source (a 4-20 mA current calibrator, for example) and not the DCS, it indicates a filter is necessary with that current source. Some 4-20 mA calibrators that work without a filter are listed below. If one of these is available, try to connect with Soft-

Tools or the HART 275/375 handheld again. If communications are established while using one of these sources but fails on the original source, a filter is needed.

Handheld 4-20 mA calibrators which do not require a filter:

- Altek Model 334
- Rochester Instrument Systems (RIS) CL-4002
- Unomat UPS-II

Q: I set the MPC at 5 percent. How will the positioner operate?

A: Assume that the present command signal is at 50 percent. If the command signal is decreased, the positioner will follow the command until it reaches 5 percent. At 5 percent, the spool will be driven fully open or fully closed, depending on the air action of the valve, in order to provide full actuator saturation and tight shutoff. The positioner will maintain full saturation below 5 percent command signal. As the command increases, the positioner will remain saturated until the command reaches 6 percent (there is a 1 percent hysteresis value added by the positioner). At this point, the stem position will follow the command signal. While in MPC, the Logix 3200/Q LEDs will blink GGGY.

Q: I have MPC set to 3 percent but the valve will not go below 10 percent.

A: Is a lower soft stop enabled? The lower soft stop must be less than or equal to zero percent in order for the MPC to become active. If a positive lower soft stop is written, this stop will take priority over the MPC feature. When the lower soft stop is reached, the positioner will blink a GYYR code.

Q: Will soft stops prevent the valve from going to its fail position?

A: No.

Q: What is the difference between a model with Standard diagnostics and a model with Advanced diagnostics?

A: The model with Advanced diagnostics adds top and bottom actuator pressure sensors. This allows for more diagnostic calculations such as loss of pressure, friction, advanced signatures, and troubleshooting. The pressure sensors, if present, are also used in the positioner control algorithm to enhance valve stability.

Q: Can I upgrade from a Standard to an Advanced?

A: Yes. Referencing the IOM, an advanced pressure sensor board assembly can be purchased. Simply replace the pressure sensor plug plate with the advanced pressure sensor board. Using SoftTools or the HART 275/375 handheld, configure the positioner for Advanced Diagnostics and perform an actuator pressure calibration.

14 How to Order

Selection		Code	Example
		3	3
Protocol	HART	2	2
Diagnostics	Standard	0	1
	Advanced	1	
Material	Aluminum, White Paint (Valtek)	0	0
	Stainless Steel, No Paint (Valtek)	1	
	Aluminum, Black Paint (Automax)	2	
	Aluminum, Food-Grade White Paint (Automax)	3	
	Aluminum, Black Paint (Accord)	4	
	Aluminum, Food-Grade White Paint (Accord)	5	
Design Version		IQ	IQ
Certifications	Explosionproof EEx d IIB + H ₂ , ATEX II 2 G (CENELEC)	07	10
	Explosionproof Class I, Div 1, Groups B, C, D Intrinsically Safe Class I, Div 1, Groups A through G (FM, CSA) FM Nonincendive. CSA Class I, Div 2, Class I, Zone 1, Group IIB + H ₂ and Exia Class 1, Zone 0, Group IIC (CSA Only)	10	
	General Purpose	14	
	Intrinsically Safe EEx ia IIC T4/T5, Standard Temp: -4°F (-20°C) ≤ Ta ≤ 176°F (80°C)/13°F (55°C), Low Temp: -40°F (-40°C) ≤ Ta ≤ 176°F (80°C)/131°F (55°C), ATEX II 1 G (CENELEC)	15	
Shaft	DD 316 Stainless Steel Shaft (Valtek Standard)	D6	D6
	NAMUR 316 Stainless Steel (VDI/VDE 3845)	N6	
Conduit Connections	½" NPT	E	E
	M20	M	
Action	Four-way (Double-Acting)	4	4
	Three-way (Single-Acting)	3	
	Four-way Vented (Double-Acting)	4V	
	Three-way Vented (Single-Acting)	3V	
Temperature	Standard Temperature (-4°F to 176°F; -20°C to 80°C)	20	20
	Low Temperature (-40°F to 176°F; -40°C to 80°C)	40	
Gauges	Gauges (Valtek standard)	G	G
	Stainless Steel Gauges	S	
	No Gauges	U	
Special Options	4-20 mA Position Feedback	F	F

15 Troubleshooting

Failure	Probable Cause	Corrective Action
No LED is blinking	Current source below 3.6 mA without AO card or 3.7 mA with AO card	Verify current source is outputting at least 3.6 mA with AO card or 3.7 mA with AO card
	Incorrect wiring polarity	Check wiring for correct polarity
	Voltage of current source is not high enough	Verify that current source can supply at least 10 V
Erratic communications	Current source bandwidth not limited to 25 Hz	Maximum allowable current source rate of change is 924 mA per second
	Maximum cable length or cable impedance exceeded	Check cable conduction size, length and capacitance. Refer to Section 6.4, "Cable Requirements"
	HART modem connected to PC RS-232 port not receiving enough power	Verify laptop battery is not low
	Interference with I.S. barrier	Must use HART-compatible I.S. barrier
	Current Source stripping (filtering) HART signal.	Use the HART filter (VHF) available from Flowserve
Unit does not respond to analog commands	Unit is in digital command mode	Switch to analog command mode by doing a Command Source Reset from the local interface or with a handheld communicator or SoftTools (please refer to Section 7.9, "Command Source Reset," or the quick start guide for detailed instructions).
	Error occurred during calibration	Check blink codes on positioner and correct calibration error. Recalibrate
Valve position reading is not what is expected	Positioner tubing backwards	Re-tube the actuator
	Stem position sensor mounting is off 180°	Remount position sensor
	Stroke not calibrated	Perform QUICK-CAL
	Tight shutoff (M.P.C)* is active	Verify settings using PC or handheld software
	Customer characterization or soft stops active	Verify customer characterization and soft stops
Position is driven fully open or closed and will not respond to command	Stroke not calibrated	Check DIP switch settings and calibrate valve stroke
	Inner-loop hall sensor not connected	Verify hardware connections
	Wrong air action entered in software	Check ATO (Air-to-open) and ATC (Air-to-close) settings. Recalibrate
	Actuator tubing backward	Verify ATO/ATC actuator tubing
	Electro-pneumatic converter malfunctioning	Replace electro-pneumatic converter
	Control parameter inner-loop offset is too high/low	Adjust inner-loop offset and see if proper control resumes
Sticking or hunting operation of the positioner	Contamination of the driver module	Check air supply for proper filtering and meeting ISA specifications ISA-7.0.01. Check the spool valve for contamination
	Control tuning parameters not correct	Adjust gain settings using local gain switch
	Packing friction high	Enable the stability DIP switch on the local interface and recalibrate. If problem persists, enable pressure control with handheld communicator or SoftTools and recalibrate
	Corroded or dirty spool valve	Disassemble and clean spool valve

*M.P.C.: Minimum position cutoff

Flowserve Corporation has established industry leadership in the design and manufacture of its products. When properly selected, this Flowserve product is designed to perform its intended function safely during its useful life. However, the purchaser or user of Flowserve products should be aware that Flowserve products might be used in numerous applications under a wide variety of industrial service conditions. Although Flowserve can (and often does) provide general guidelines, it cannot provide specific data and warnings for all possible applications. The purchaser/user must therefore assume the ultimate responsibility for the proper sizing and selection, installation, operation, and maintenance of Flowserve products. The purchaser/user should read and understand the Installation Operation Maintenance (IOM) instructions included with the product, and train its employees and contractors in the safe use of Flowserve products in connection with the specific application.

While the information and specifications contained in this literature are believed to be accurate, they are supplied for informative purposes only and should not be considered certified or as a guarantee of satisfactory results by reliance thereon. Nothing contained herein is to be construed as a warranty or guarantee, express or implied, regarding any matter with respect to this product. Because Flowserve is continually improving and upgrading its product design, the specifications, dimensions and information contained herein are subject to change without notice. Should any question arise concerning these provisions, the purchaser/user should contact Flowserve Corporation at any one of its worldwide operations or offices.

For more information about Flowserve Corporation, visit www.flowserve.com or call USA 1-800-225-6989.

**FLOWSERVE CORPORATION
FLOW CONTROL DIVISION**

1350 N. Mt. Springs Parkway
Springville, UT 84663
Phone: 801-489-8611
Fax: 801-489-3719