

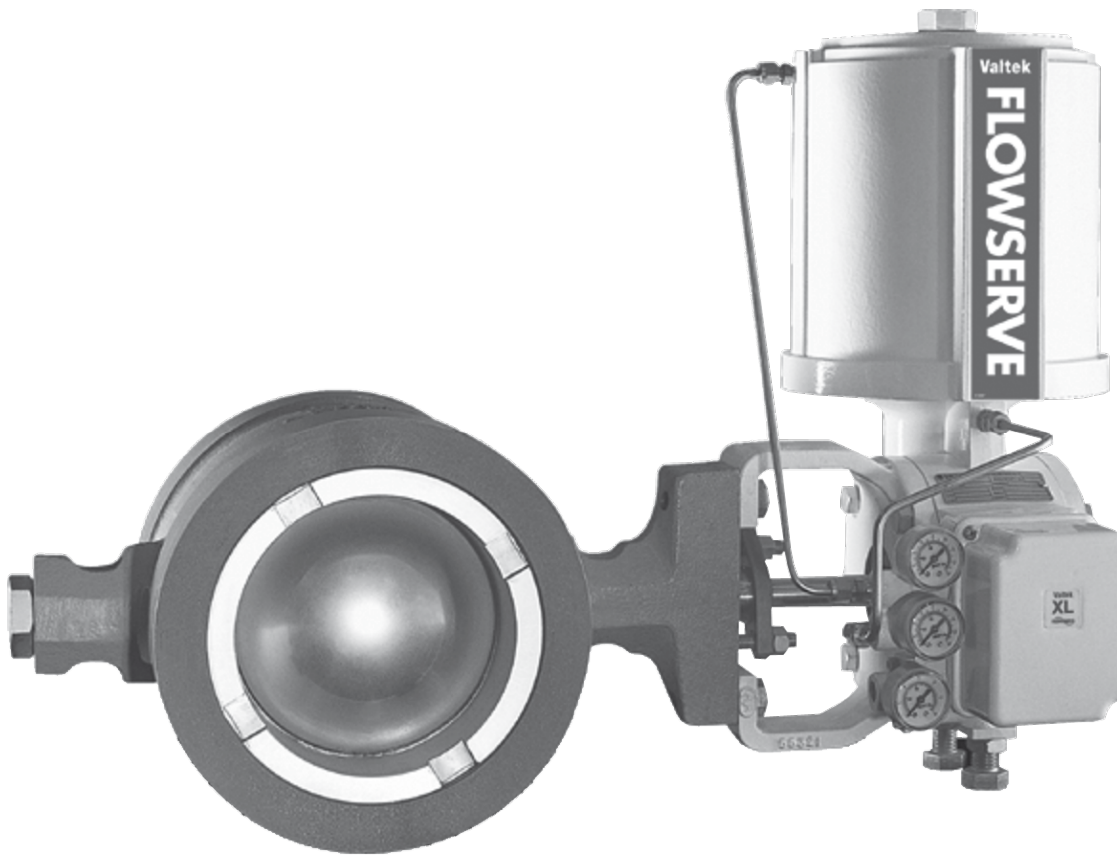

USER INSTRUCTIONS

Valtek ShearStream HP Control Valves
Segmented V-Port Ball Valves

*Installation
Operation
Maintenance*



Contents

- 1 General Information
- 2 Unpacking
- 3 Installation
- 4 Quick Check
- 5 Preventative Maintenance
- 6 Removing Valve From Line
- 7 Removing Actuator From Body
- 8 Disassembly and Reassembly
- 9 Remounting the Actuator

Figures

- Figure 1 Body Assembly, >2-inch
- Figure 2 Body Assembly, 1 – 2-inch
- Figure 3 Packing Configurations
- Figure 4 Seat Configurations
- Figure 5 Exploded Body Subassembly

Tables

- Table I Flange Bolting Specifications
- Table II Screwed-in Retainer Torques
- Table III Post/Shaft Plug Torques
- Table IV Optional ShearStream Tools
- Table V Troubleshooting Chart

1 GENERAL INFORMATION

1.1 Use

The following instructions are designed to assist in the unpacking, installation, and maintenance as required for Flowserve products. Product users and maintenance personnel should thoroughly review this manual prior to installing, operating, or performing any maintenance. In most cases, Flowserve valves, actuators and accessories are designed for specific applications (e.g. with regard to medium, pressure and temperature). For this reason, they should not be used in other applications without first contacting the manufacturer.

1.2 Applicability

The following instructions are applicable to the maintenance and installation of Valtek ShearStream HP control valves. These instructions cannot claim to cover all details of all possible product variations, nor can they provide information for every possible example of installation, operation or maintenance. This means that the instructions normally include only the directions to be followed by qualified personal using the product for its defined purpose. If there are any uncertainties in this respect, particularly in the event of missing product-related information, clarification must be obtained via the appropriate Flowserve sales office. Flowserve User Manuals are available at www.flowserve.com.

1.3 Terms related to safety

The terms **DANGER**, **WARNING**, **CAUTION**, **NOTE** are used in this document to highlight particular dangers and/or to provide additional information on points which may not be clearly obvious.



DANGER: Indicates that death, severe personal injury and/or substantial property damage **will** occur if proper precautions are not taken.



WARNING: Indicates that danger of death or severe personal injury and/or property damage **can** occur if proper precautions are not taken.



CAUTION: Indicates that minor personal injury and/or serious damage to property can occur if the appropriate precautions are not taken.



NOTE: Indicates and provides additional technical information which may not be obvious, even to qualified personnel.

Compliance with other notes, which may not be particularly emphasized, with regard to transport, assembly, operation and maintenance and with regard to technical documentation (e.g. in the operating instructions, product documentation, or on the product itself) is essential, in order to avoid faults, which can directly or indirectly cause severe personal injury or property damage..

1.4 Protective clothing

Flowserve products are often used in problematic applications (e.g. under extremely high pressures with dangerous, toxic or corrosive mediums). When performing service, inspection, or repair operations, always ensure that the valve and the actuator are depressurized and that the valve has been cleaned, and that it is free of harmful substances. In such cases, pay particular attention to personal protection (e.g. protective clothing, gloves, glasses etc).

1.5 Qualified personnel

Qualified personnel are people who on account of their education, experience, training, and knowledge of relevant standards, specifications, accident prevention, and operating conditions have been authorized by those responsible for the safety of the plant to perform the necessary work, and recognize and avoid possible dangers.

1.6 Spare Parts

Use only Flowserve original spare parts. Flowserve cannot accept responsibility for any damages that occur from using spare parts or fastening materials from other manufacturers. If Flowserve products (especially sealing materials) have been on store for long periods of time, check them for corrosion or deterioration before putting them into use.

1.7 Service / Repair

To avoid possible injury to personnel or damage to products, safety terms must be strictly adhered to. Modifying this product, substituting non-factory parts, or using maintenance procedures other than those outlined in these Installation, Operation and Maintenance Instructions could drastically affect performance, be hazardous to personnel and equipment, and may void existing warranties. Between the actuator and the valve there are moving parts. To avoid injury, Flowserve provides pinch-point-protection in the form of cover plates, especially where side-mounted positioners are fitted. If these plates are removed for inspection, service or repair special attention is required. After completing work the cover plates must be refitted. Apart from the operating instructions and the obligatory accident prevention directives valid in the country of use, all recognized regulations for safety and good engineering practices must be followed.



WARNING: Before products are returned to Flowserve for repair or service, Flowserve must be provided with a certificate that confirms that the product has been decontaminated and is clean. Flowserve will not accept deliveries if a certificate has not been provided (a form can be obtained from Flowserve).

1.8 Storage

In most cases, Flowserve products are manufactured from stainless steel. Products not manufactured from stainless steel are provided with an epoxy resin coating. This means that Flowserve products are well protected from corrosion. Nevertheless, Flowserve products must be stored adequately in a clean, dry, environment. Plastic caps are fitted to protect the flange faces and prevent the ingress of foreign materials. These caps should not be removed until the valve is actually mounted into the system.

2 UNPACKING

2.1 While unpacking the valve, check the packing list against the materials received. Lists describing the valve and accessories are included in each shipping container.

2.2 When lifting the valve from shipping container, use straps through the yoke legs. Take care to position lifting straps to avoid damage to the tubing and mounted accessories.



WARNING: When lifting a valve be aware that the center of gravity may be above the lifting point. Therefore, support must be given to prevent the valve from rotating. Failure to do so can cause serious injury to personnel and damage to the valve and nearby equipment.

2.3 Contact your shipper immediately if there is shipping damage.

2.4 Should any problem arise, call your Flowserve representative.



DANGER: Before installation check the order number, serial number, and/or the tag number to ensure that the valve and actuator being installed are correct for the intended application.



CAUTION: Do not insulate extensions that are provided for hot or cold services.

3 INSTALLATION

3.1 Before installing the valve, clean the pipeline of all contamination, carbon deposits, welding chips, and other foreign material. Carefully clean gasket surfaces to ensure a tight seal. Pipelines must be correctly aligned to ensure that the valve is not fitted under tension.

3.2 Fire protection must be provided by the user.

3.3 Check the direction of fluid flow to ensure that the valve is correctly installed. Flow direction is indicated by the arrow attached to the body. All installation orientations for fitting the valve into the pipeline are defined at the end of this manual.



DANGER: To avoid serious injury, keep hands, hair, clothing, etc away from the ball and seat when the valve is working.

3.4 Whenever possible, the valve should be installed so that actuator is in an upright position. Vertical installation of the actuator permits easier valve maintenance.

3.5 Connect the air supply and instrument signal lines. Throttling control valves are equipped with a valve positioner. Connections are marked for the air supply and the instrument signal. Check that the actuator and positioner can withstand the maximum air supply from the network. The required air supply is indicated on a sticker located on the actuator. An air regulator will be necessary in certain cases in order to limit the supply pressure. A filter is recommended unless the air supplied is exceptionally clean and dry (air quality without humidity, oil, or dust as per IEC 770 and ISA-7.0.01). All connections must be completely tight.



CAUTION: On valves equipped with air filters, the air filter must point down to perform properly.

3.6 Use the bolts indicated in Table I for installing the valve in the pipeline, and then tighten alternately according to good practice. The user must in all cases confirm the capacity of the bolts to ensure a sufficiently tight gasket seal for the expected service conditions.

3.7 Be sure to provide proper overhead clearance for the actuator to allow for disassembly of the actuator from the valve body. Refer to the appropriate to the ShearStream HP Technical Bulletin for proper clearances. ShearStream HP Technical Bulletin is available at www.flowserve.com.

4 QUICK-CHECK

Before commissioning, check the control valve by following these steps:

4.1 Check for full stroke by varying the instrument signal settings appropriately. Observe the ball position indicator located on the actuator or the positioner. The ball should change position with a smooth turning movement.

4.2 Check all air connections for leaks. Tighten or replace any leaking lines.

4.3 Check packing box bolting for proper tightness.



CAUTION: Do not overtighten packing. This can cause excessive packing wear and high stem friction that may impede shaft movement. After the valve has been in service for a short period, recheck the packing-box nuts. If the packing-box leaks, tighten the nuts just enough to stop the leak.

4.4 Make sure the valve fails in the correct direction in case of air failure. This is done by positioning the valve at mid-stroke and turning off the air supply and observing the failure direction. If the action is incorrect, see the section "Reversing the Air-action" in the instructions of the installation, operation and maintenance manual of the appropriate actuator.

5 PREVENTATIVE MAINTENANCE

At least once every six months, check for proper operation by following the preventative maintenance steps outlined below. These steps may be performed while the valve is in-line and without interrupting service. If an internal problem is suspected, refer to section "Valve Disassembly".

- 5.1 Look for signs of gasket leakage through the end flanges and post. If necessary, re-torque end flanges and post.
 - 5.2 Examine the valve for damage caused by corrosive fumes or process drippings.
 - 5.3 Clean the valve and repaint areas of severe oxidation.
 - 5.4 Check the packing-box for proper tightness. If there is a persistent leak, change the packing after referring to sections "Valve Disassembly and Body Reassembly".
-  **CAUTION:** Do not overtighten packing. This can cause excessive packing wear and high friction that may impede shaft movement.
- 5.5 If the valve is equipped with a lubricator, add lubricant if necessary.
 - 5.6 If possible, stroke the valve and check for smooth, full-stroke operation. Unsteady shaft movement may indicate an internal valve problem.
 - 5.7 Check the calibration of the positioner. For further preventative maintenance, see the instructions in the installation, operation and maintenance manual for the applicable positioner.
 - 5.8 Ensure all accessories, brackets and bolting are securely fastened.
 - 5.9 If possible, remove air supply and observe actuator for correct fail-safe action.
 - 5.10 Check the actuator and all air connections for leaks.
 - 5.11 If an air filter is supplied, check and replace the cartridge if necessary.

Table I: Flange Bolting Specifications

Valve Size (inches)	ANSI Class Rating	Bolt** Length (inches)	Torque* (ft.-lbs.)	
			Low Strength	Intermediate Strength
1	150	2.5	23	61
	300	3.0	46	122
	600	3.5	46	122
1½	150	2.75	23	61
	300	3.5	82	218
	600	4.25	82	218
2	150	3.25	46	122
	300	3.5	46	122
	600	4.25	46	122
3	150	3.5	46	122
	300	4.25	82	218
	600	5.0	82	218
4	150	3.5	46	122
	300	4.5	82	218
	600	5.75	132	353
6	150	4.0	82	218
	300	4.75	82	218
	600	6.75	199	531
8	150	4.25	82	218
	300	5.5	132	353
	600	7.5	296	789
10	150	4.5	132	353
	300	6.25	199	531
	600	8.5	420	1119
12	150	4.75	132	353
	300	6.75	296	789
	600	8.75	420	1119
16	150	5.50	199	531
	300	7.75	420	1119
	600	10.00	667	1760

*Torque values are recommended for low and intermediate strength bolting per ANSI B16.5 ¶5.3.2. Higher torques may be used with high strength bolting (ANSI B16.5 ¶5.3.1). In all cases the user must verify the selected bolting's ability to seat the joint under expected operating condition. Long thru-bolted joints generally require higher strength bolting and torque values than shorter flanged bolting depending on operating conditions.

**Lengths are based on ANSI B16.5 stud bolts and raised face ends.

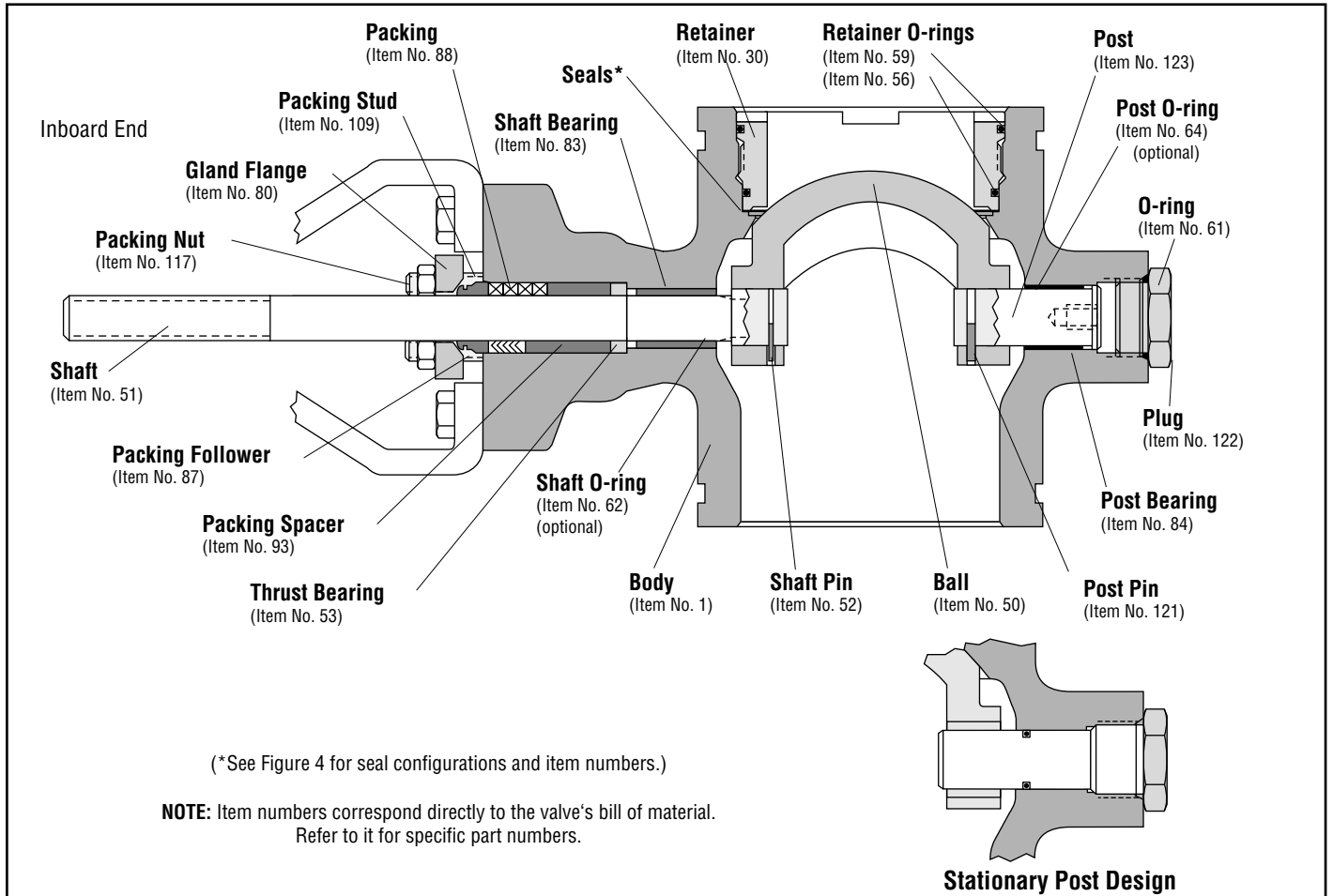

Figure 1: 3 – 12-inch and 16-inch ShearStream HP Body Assembly with Rotating Post Design

6 Removing Valve From Line

If an internal problem is suspected with the valve and disassembly is required, remove the valve from the line by proceeding as follows:



WARNING: Depressurize line to atmospheric pressure, drain all process fluids and decontaminate the valve (if caustic or hazardous materials are present). Failure to do so can cause serious injury.

- 6.1 Attach a hoist or some means to support the valve.
- 6.2 Remove line bolting. Do not attempt to pry line flanges apart by pushing or pulling on the valve or actuator.
- 6.3 Slide the valve carefully from the line. To avoid damage to the gasket surfaces, do not twist the valve.
- 6.4 After the valve is completely removed from the line, slowly relieve air pressure from the actuator.

7 Removing Actuator From Body

Sizes 3 – 12-inch and 16-inch ShearStream valves are designed to be disassembled without removing the Flowserve actuator, however, removing the actuator is recommended. Refer to actuator installation, operation, maintenance instructions, and proceed as follows:

- 7.1 Support the actuator assembly before disconnecting it from the body assembly.
- 7.2 Loosen the actuator adjusting screw to release the spring compression.
- 7.3 On Valtek rotary actuators with a clamped lever-arm design, remove the actuator transfer case cover bolts, carefully pry or slide the cover plate from the transfer case, then loosen the linkage bolt.
- 7.4 Remove bolts connecting yoke to body subassembly.
- 7.5 Slide the entire actuator assembly off the shaft. On Valtek rotary actuators with a clamped lever-arm design, it may be necessary to wedge the splined lever arm apart to loosen it from the shaft splines.

8 DISASSEMBLY AND REASSEMBLY

8.1 Disassembling the Body

Removing the actuator from the body assembly to disassemble 3 – 12-inch and 16-inch bodies is not necessary; however, this procedure is recommended. On valves with the clamped lever-arm design loosening the valve shaft from

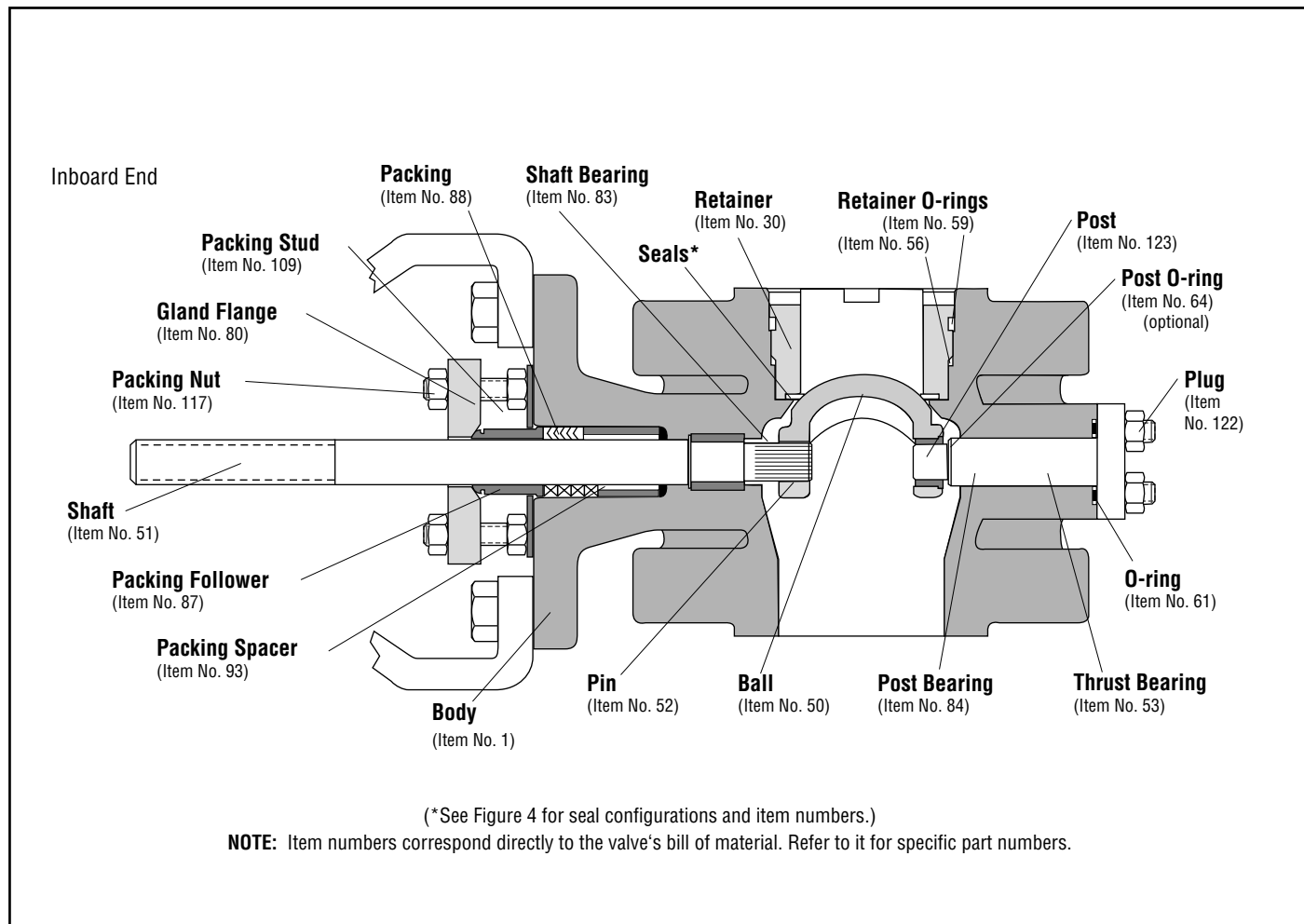

Figure 2: 1 – 2-inch ShearStream HP Body Assembly

the actuator prior to body disassembly is necessary. Refer to Figures 1, 2 and 5 and proceed as follows:

8.1.1 Remove the seal retainer and seals.

Screw-in style – This requires loosening the retainer by turning it counterclockwise and removing it from the body. (A special cross-wrench tool may be ordered from the factory. See Table IV.) Remove the metal seals. Remove the soft seal if applicable.

Lock-ring style – Some valve designs have a retaining ring held in with set screws. To remove it, loosen the set screws in the lock ring, then remove the retaining ring, lock ring and finally the seal retainer. If the lock ring set screws will not loosen, the retaining ring can be forced out using a flat-headed screwdriver and pliers. Remove the seals.

8.1.2 Remove the gland flange by removing both packing nuts. Removing the studs is not necessary.

8.1.3 **On rotating post designs**, drive both the shaft and post pins into the center of the shaft and post until the outward end of the pin clears the ball. Be careful to not damage the shaft or post. The pins can then be punched out of the shaft and post

when they are removed from the valve. Carefully remove the shaft plug and O-ring and finally the rotating post. (Inserting a bolt in the jack screw hole, tapped in the post, will help in removing the post.)

On stationary post designs, drive the shaft pin into the center of the shaft until the outward end of the pin clears the ball splines. Be careful to not damage the shaft. The pin can then be punched out of the shaft after the shaft is removed. Remove the anti-rotation clamp. Remove the post and the post O-rings.

8.1.4 On 3 – 12-inch and 16-inch designs, remove the shaft by pulling it out through the outboard end of the body. On 1 – 2-inch designs, remove the shaft by pulling it out through the inboard end of the body



CAUTION: Take special care to not damage the splined end of valve shaft during disassembly.

8.1.5 Rotate the ball inside the body so the non-splined end of the ball is toward the back port of the valve and remove the ball straight out of the body. If necessary, on stationary post designs remove the post bearing from the ball by pushing it out with a press.

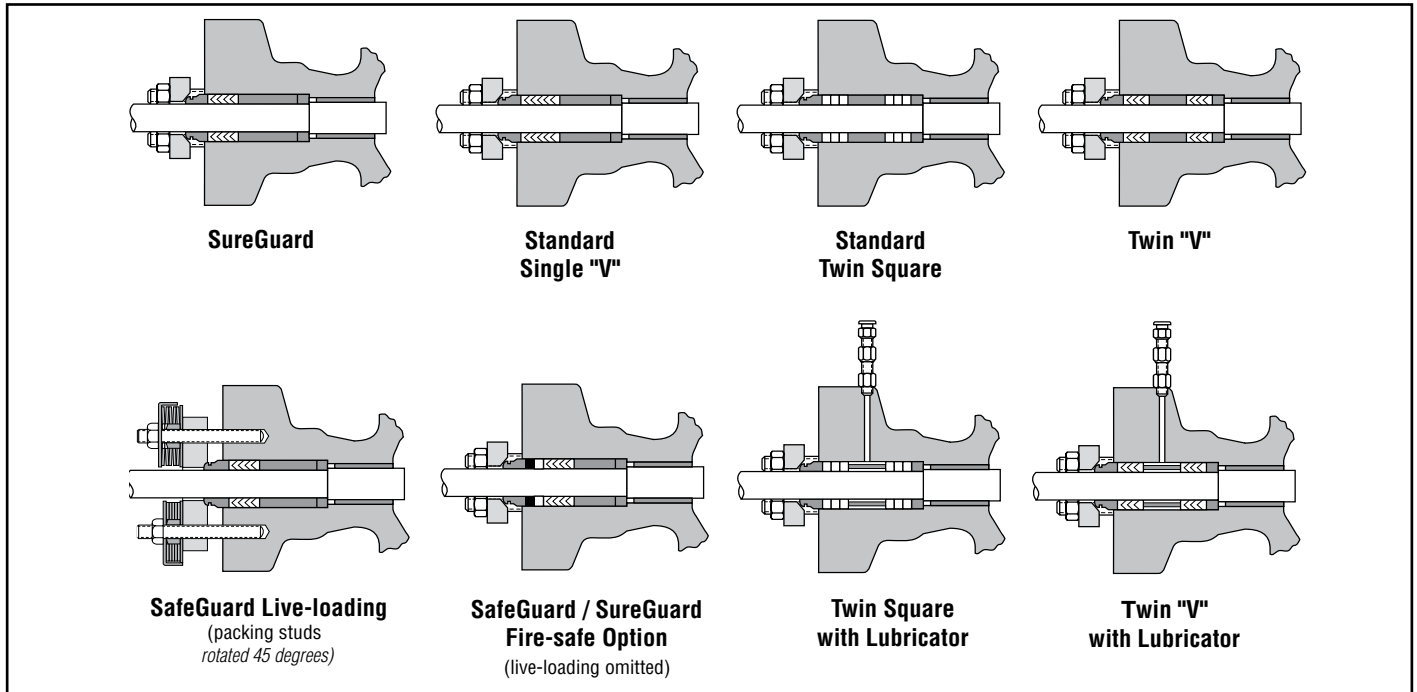

Figure 3: ShearStream HP Packing Configurations



CAUTION: Be extremely careful not to gall or scratch the sealing surface of the ball when removing it from body. Scratches may later cause excessive leakage and seal wear.

8.1.6 Push packing and bearings out of the body using a bronze dowel with the appropriate diameter. Push packing out of the body from the center of the valve. (See Table IV for optional shaft/post bearing tool.)

8.2 Reassembling the Body

To reassemble the body subassembly, refer to Figures 1 or 2, 3, 4, and 5 and proceed as follows:

- 8.2.1 Clean all parts and replace all O-rings and soft seals.
- 8.2.2 Check the ball sealing surface to make sure it is smooth and free of scoring and scratches.



CAUTION: Damaged or dirty seal surfaces can cause excessive seat wear and high torque requirements. Damaged balls should be replaced.

8.2.3 Inspect the shaft and post for scratches or galled surfaces. For maximum performance, ShearStream shafts and posts are machined to a very smooth finish. If damage exists, replace the shaft or contact the factory representative.



NOTE: Ball and shaft are interchangeable. Replacing the ball does not require replacing the shaft.

8.2.4 Using a press to install new bearings in the body and/or ball is recommended. (An optional post/bearing tool is available from the factory. See Table IV.) When correctly installed, the ends of the body bearings should be flush with the inside of the body.

8.2.5 Position the ball in the body by lowering it, splined hole first, into the back of the body. Rotate the ball surface toward the front of the body so that the splined hole is toward the packing box.



CAUTION: Be extremely careful not to gall or scratch the sealing surface of the ball when replacing it in the body. Scratches may later cause excessive leakage and seal wear.

8.2.6 On 3 – 12-inch and 16-inch designs, insert the shaft through the outboard end of body and through the splined hole of the ball into the packing box. On 1 – 2-inch designs, insert the shaft through the inboard end of body and through the packing box into the splined hole of ball. (For 1-inch body designs, the thrust bearing, packing spacer, packing, and packing follower must be inserted before installing shaft.)

8.2.7 Position the shaft so that the pin hole in the shaft and ball are in alignment. (Some shafts have a half circle mark and line on the end. Align the line mark with the pin and the half circle symbol with the ball.) Install the shaft pin and drive it firmly into place so that half is in the ball and half in the shaft.

8.2.8 **On rotating post designs,** Insert the post through the outboard end of the body and into the hole of the ball. (For 1–2-inch valves sizes, insert thrust bearing before installing post.) Position the post so that the pin hole in the post and ball are aligned. (For 6 – 12-inch and 16-inch valve sizes, be certain that the ball pin hole is aligned with the smallest diameter pin hole in the post. Some posts have a half circle mark on the end. Align this mark with the ball.) Install the post pin and drive it firmly into place so that half is in the ball and half is in the post. Torque the plug per Table II.

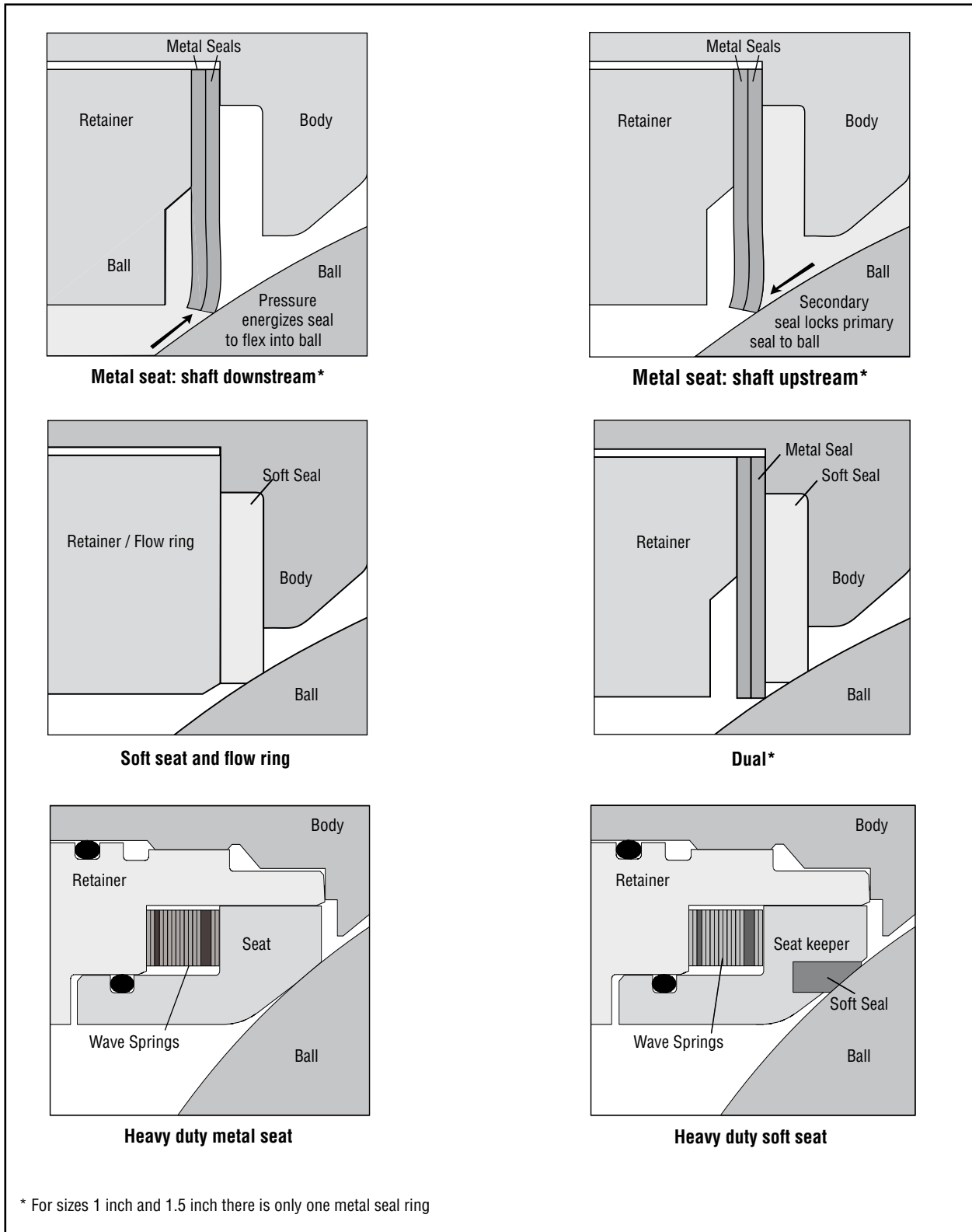



Figure 4: Seat Configurations

On stationary post designs, Ensure that the post and post threads are well lubricated with a high temperature bearing grease (or as required by the application) before installation. Replace the post O-ring and reinstall the post. Torque the post per Table II. Install the anti-rotation clamp kit.

8.2.9 Slide thrust bearing, packing spacer, packing, and packing follower over the splined end of the shaft and into body. Typical packing configurations are shown in Figure 3. (1-inch designs refer to Step 6.)

 **NOTE:** Always use new packing whenever rebuilding the packing box.

 **CAUTION:** Since the sealing on V-ring packing takes place at the feather edge, it is imperative to avoid damage to that edge.

8.2.10 Reinstall the gland flange and packing nuts and leave loose.

 **CAUTION:** Do not overtighten packing. This can cause excessive packing wear and shaft friction, which may impede shaft rotation.

8.2.11 Place the valve on a flat surface with the threaded (retainer) port facing up and pull the shaft toward the actuator until it is fully against the thrust bearing.

8.2.12 **On 3 – 12-inch and 16-inch designs,** make certain the ball surface is facing up and position the ball as close as possible in the center of the body's inside diameter. (The pinned connection between the ball and shaft is not a tight connection; the design includes a considerable amount of axial play between the ball and shaft.)

On 1 – 2-inch designs, make certain the ball surface is facing up and pull on the shaft until the post is fully against the thrust bearing. (The ball does not self center. No axial play should occur between the ball and shaft.)

8.2.13 Replace the seat as applicable to the valve. (Refer to Figure 4.)

For metal seats, insert the two metal seal rings into the body. (See note on Figure 4.)

For soft seats, insert the soft seal ring into the body.

For dual seats, insert the soft seal ring, followed by the two metal seal rings into the body. (See note on Figure 4.)

For heavy duty metal seats or heavy duty soft seats, first lubricate the seat o-ring and install into the seat. Next lubricate the mating surfaces between the seat and seat retainer. Then place one shim in the retainer, followed by all of the wave springs, and then the remaining shims. Next place the seat into seat retainer, so the seat is resting on the shims and wave springs. For heavy duty metal seats, lubricate the contact surfaces between the seat and ball. Follow instructions in 8.2.14 for simultaneously installing the seat retainer and heavy duty seat into the body.

8.2.14 With screwed-in retainer designs, replace the O-rings in the retainer (except on high temperature valves, which do not use O-rings). Refer to Figure 1 or 2. Lubricate the retainer threads and rings and reinstall the retainer in the front of the body. Torque the seal retainer according to

Table II: Post/Shaft Plug Torques (ft.-lbs.)

Valve Size (inches)	Rotating Post Design (Shaft Plug)
1, 1.5*	50
2*	85
3, 4	150
6, 8	250
10, 12	300
16*	N/A

* Flanged post; torque values not required.

Table III.

8.2.15 On some 10, 12 and 16-inch valves where the retainer is held in place with set screws, reinsert the lock ring into the body with the words 'Ball Side' facing toward the ball. The lock ring has 'Ball Side' and 'Port Side' marked on it. Insert the retaining ring into the inner groove of the body, being certain it is fully seated. Tighten the lock ring setscrews evenly to a torque of 225 inch-pounds.

8.2.16 After the seal retainer is in tight, tighten the packing nuts just over finger-tight. Packing nuts should be tightened as necessary to prevent stem leakage.

 **CAUTION:** Do not overtighten packing. This can cause excessive packing wear and high shaft friction, which may retard shaft rotation.

9 Remounting the Actuator

Before mounting a Flowserve actuator on the valve body, verify that the ball rotation matches the actuator rotation and complies with the air failure requirements. Procedure for mounting the actuator is as follows:

9.1 Slide the entire actuator assembly onto the shaft. (If necessary on Flowserve actuator designs with clamped lever-arm design, wedge the splined lever arm apart to loosen it on the shaft splines.)

9.2 Bolt the yoke to the valve body.

9.3 Position the actuator lever arm on the shaft so the actuator stem is centered in the transfer case.

9.4 On clamped lever-arm actuator designs, firmly tighten the linkage bolt. Bolt the transfer case cover plate into place.

9.5 Align the stroke indicator plate on the end of spline lever so it accurately indicates ball position.

 **CAUTION:** On clamped lever-arm actuators, never apply air to the actuator without the cover plate installed; otherwise, the unsupported shaft may sustain damage.

9.6 Install valve in line as outlined in Installation section.

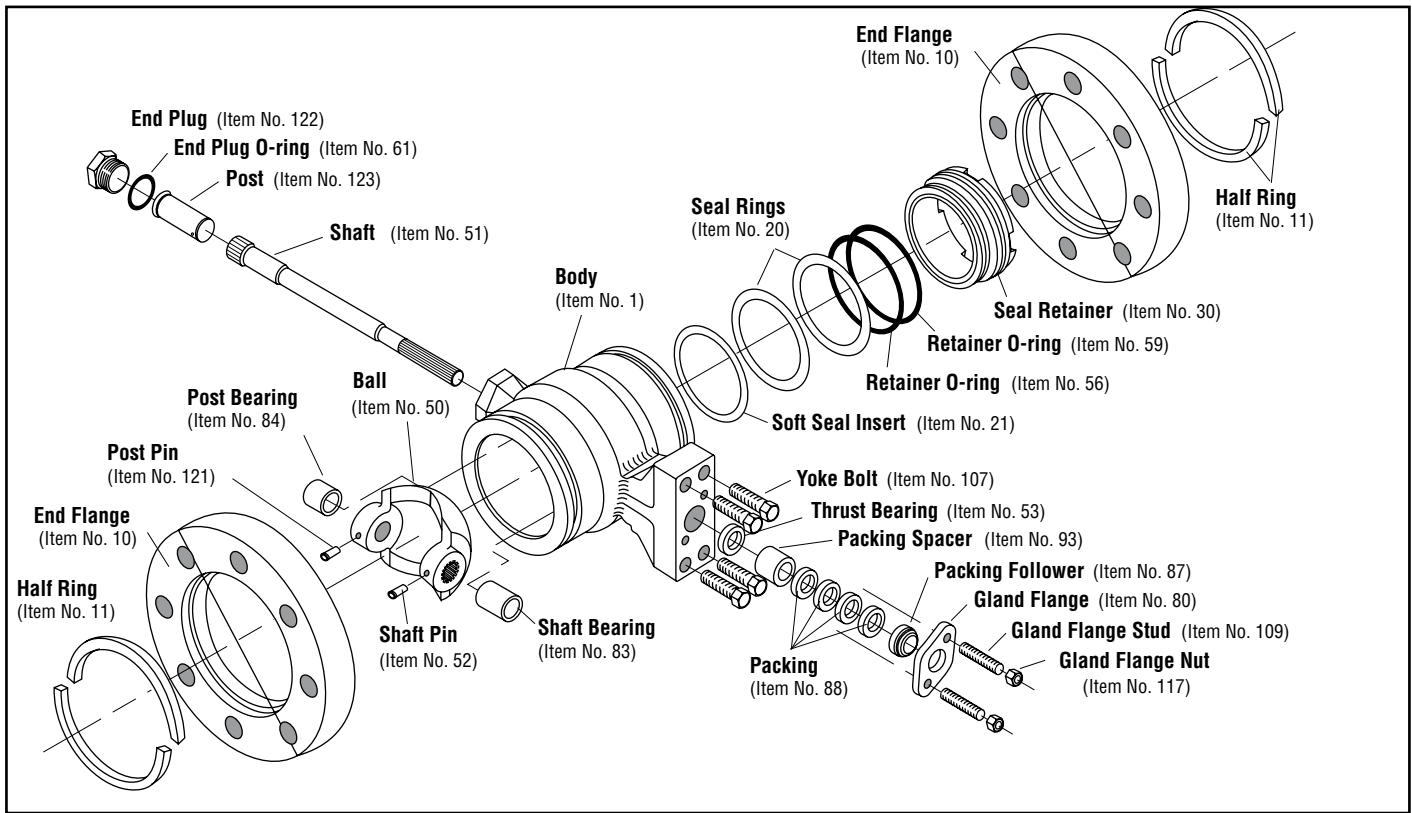

Figure 5: Exploded Body Subassembly, 3 – 12-inch and 16-inch Rotating Post Design

NOTE: Item numbers correspond directly to the valve's bill of material. Refer to it for specific part numbers.

Table III: Screwed-in Retainer Torques

Valve Size (inches)	Torque Value (ft.-lbs.)	Valve Size (inches)	Torque Value (ft.-lbs.)
1, 1.5, 2	150-175	8, 10	650-700
3	250-300	12	900-950
4, 6	550-600	16*	N/A

* Clamped design; torque value not required.

Table IV: Optional ShearStream Tools

Valve Size (inches)	Retainer Tool	Shaft/Post Bearing Tool
1	87377	76891
1.5	87530	76509
2	76112	76509
3	62295	75970
4	62294	75970
6	62296	81978/81974
8	62336	81978/81974
10	81775	76550/76551
12	81034	76550/76551
16	N/A*	97967 / 97966

* Clamped design; retainer tool not required.

Table V: Troubleshooting ShearStream Ball Valves

Failure	Probable Cause	Corrective Action
Valve moves to failure position, excessive air bleeding from transfer case	<ol style="list-style-type: none"> 1 Failure of actuator stem O-ring 2 Failure of sliding seal assembly 	<ol style="list-style-type: none"> 1 Replace actuator stem O-ring 2 Repair or replace stem adapter/linkage assembly
Jerky shaft rotation	<ol style="list-style-type: none"> 1 Overtightened packing box 2 Improper adjustment of lever arm on shaft causing arm to contact transfer case, thus failing to convert torque 3 Actuator cylinder wall not lubricated 4 Worn piston O-ring allowing piston to gall on cylinder wall 5 Worn actuator stem O-ring causing actuator stem to gall on stem collar 6 Worn (or damaged) thrust bearing, shaft bearing or packing followers 	<ol style="list-style-type: none"> 1 Retighten packing box nut to slightly over finger-tight 2 Readjust lever arm; see actuator maintenance instructions 3 Lubricate actuator cylinder wall with silicone lubricant 4 Replace O-ring; if galling occurred, replace all damaged parts 5 Replace O-ring; if actuator stem is galled, replace it 6 Disassemble and inspect parts; replace any worn or damaged parts
Excessive leakage through seal	<ol style="list-style-type: none"> 1 Improper adjustment of external stroke stops on actuator 2 Worn or damaged seal 3 Damaged ball sealing surface 4 Improper handwheel adjustment acting as limit-stop 5 Ball not centered in body I.D. 	<ol style="list-style-type: none"> 1 Adjust the external stroke stops; see maintenance instructions 2 Replace seal 3 Replace ball (and shaft, if worn) 4 Adjust handwheel until ball seals properly 5 Center ball; replace damaged seals
Leakage through line flanges	<ol style="list-style-type: none"> 1 Dirty line gasket surfaces 2 Worn gaskets 3 Improper torque on line flanges 4 Flange or pipe misalignment 	<ol style="list-style-type: none"> 1 Clean gasket surfaces, reinstall valve 2 Replace gaskets 3 Tighten line flanges evenly and completely (see Table I for proper torque) 4 Realign flanged ends with piping
Leakage through packing box	<ol style="list-style-type: none"> 1 Loose packing box nuts 2 Worn or damaged packing 3 Dirty or corroded packing box 	<ol style="list-style-type: none"> 1 Tighten packing box nuts over finger-tight 2 Replace packing 3 Clean body bore, stem, replace packing
Valve slams, won't open, or causes severe water hammer	<ol style="list-style-type: none"> 1 Improper valve installation 	<ol style="list-style-type: none"> 1 See step 2 in the "Installation" section and correct flow direction
Shaft rotates, ball remains open or closed	<ol style="list-style-type: none"> 1 Broken shaft 	<ol style="list-style-type: none"> 1 Replace shaft
Actuator operates, shaft does not rotate	<ol style="list-style-type: none"> 1 Broken internal actuator parts 	<ol style="list-style-type: none"> 1 Refer to appropriate actuator maintenance instructions



Flowserve Corporation has established industry leadership in the design and manufacture of its products. When properly selected, this Flowserve product is designed to perform its intended function safely during its useful life. However, the purchaser or user of Flowserve products should be aware that Flowserve products might be used in numerous applications under a wide variety of industrial service conditions. Although Flowserve can (and often does) provide general guidelines, it cannot provide specific data and warnings for all possible applications. The purchaser/user must therefore assume the ultimate responsibility for the proper sizing and selection, installation, operation and maintenance of Flowserve products. The purchaser/user should read and understand the Installation Operation Maintenance (IOM) instructions included with the product, and train its employees and contractors in the safe use of Flowserve products in connection with the specific application.

While the information and specifications presented in this literature are believed to be accurate, they are supplied for informative purposes only and should not be considered certified or as a guarantee of satisfactory results by reliance thereon. Nothing contained herein is to be construed as a warranty or guarantee, express or implied, regarding any matter with respect to this product. Because Flowserve is continually improving and upgrading its product design, the specifications, dimensions and information contained herein are subject to change without notice. Should any question arise concerning these provisions, the purchaser/user should contact Flowserve Corporation at any of its worldwide operations or offices.

To find your local Flowserve representative, visit www.flowserve.com/SalesLocator

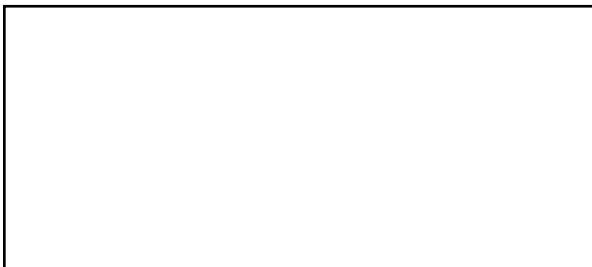

Flowserve and Valtek are registered trademarks of Flowserve Corporation.

FCD VLENIM0027-01 03/08

©2007 Flowserve Corporation. Flowserve Corporation, Valtek Control Products, Tel. USA 801 489 8611

Flowserve Corporation

Flow Control
1350 N. Mt. Springs Parkway
Springville, UT 84663
USA
Phone: +1 801 489 8611
Fax: +1 801 489 3719

Flowserve (Austria) GmbH

Control Valves - Villach Operation
Kasernengasse 6
9500 Villach
Austria
Phone: +43 (0)4242 41181 0
Fax: +43 (0)4242 41181 50

Flowserve India Controls Pvt. Ltd

Plot # 4, 1A, E.P.I.P, Whitefield
Bangalore Karnataka
India 560 066
Phone: +91 80 284 10 289
Fax: +91 80 284 10 286

NAF AB

Gelbgjutaregatan 2
SE-581 87 Linköping
Sweden
Phone: +46 (0)13 31 61 00
Fax: +46 (0)13 13 60 54

Quick Response Centers

Flowserve Deer Park

5114 Railroad Street
Deer Park, TX 77536 USA
Phone: 281 479 9500
Fax: 281 479 8511

Flowserve Baton Rouge

12134 Industriplex Blvd
Baton Rouge, LA 70809
Phone: 225-751-9880
Fax: 255-755-0728

Flowserve Philadelphia

104 Chelsea Parkway
Boothwyn, PA 19061 USA
Phone: 610 497 8600
Fax: 610 497 6680

Flowserve Singapore

12 Tuas Avenue 20
Rep. of Singapore 638824
Phone: (65) 68-798-900
Fax: (65) 68-624-940